

ESCALA/SCALE 1:80

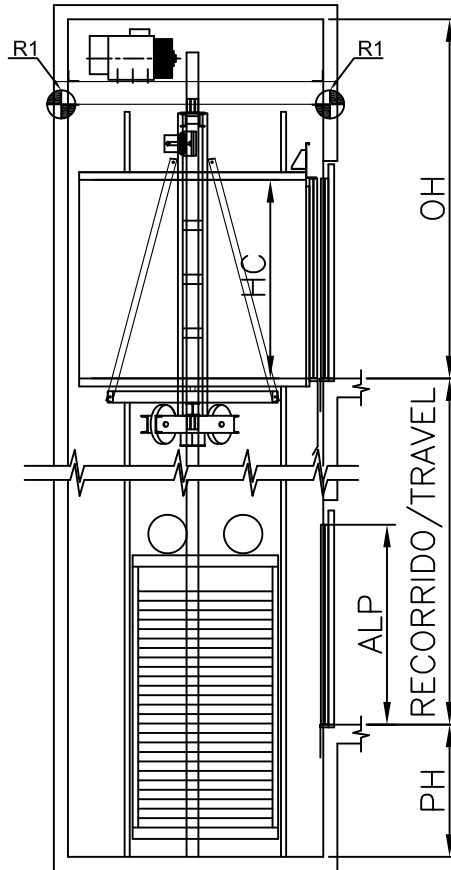

ESCALA/SCALE 1:40

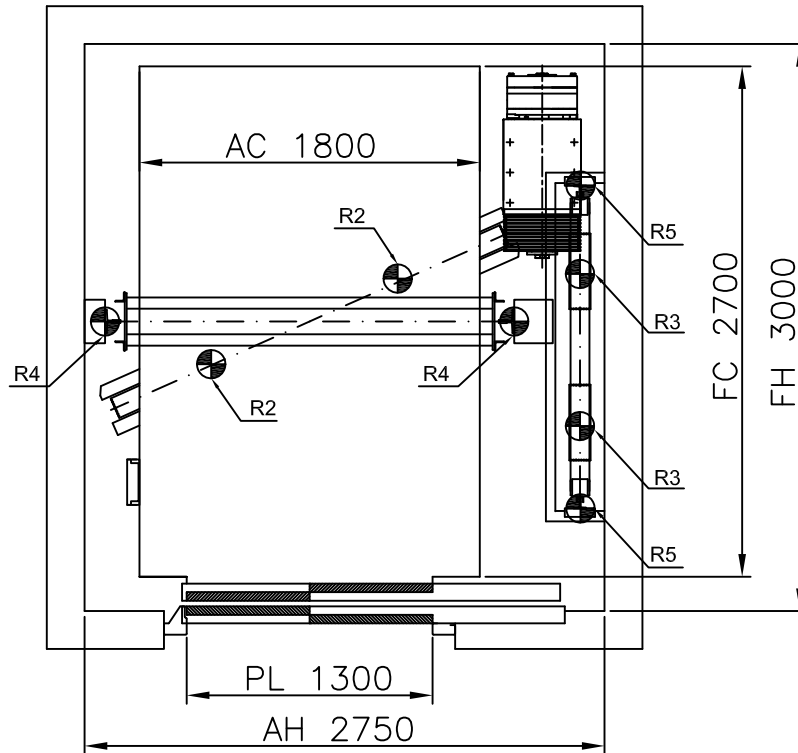

ACCIONES SOBRE EL HUECO / SHAFT REACTIONS

R1	CARGA SOBRE PARED / WALL LOAD	80000 N
R2	CARGA EN PUFFER CAB / CAR BUFFER LOAD	87000 N
R3	CARGA EN PUFFER CPSO / CTW BUFFER LOAD	62400 N
R4	CARGA EN GUÍA CAB / CAR GUIDE LOAD	48700 N
R5	CARGA EN GUÍA CPSO / CTW GUIDE LOAD	1650 N
	REACCION DE GUIAS Sx / GUIDES REACTIONS Sx	2187 N
	REACCION DE GUIAS Sy / GUIDES REACTIONS Sy	3500 N

MP3310 GO! "S"

2500 Kg	1 m/s
33 P.	GO!
FOSO/PIT	HUIDA/OVERHEAD
1400	3800



16 Kw

ESCALA/SCALE 1:80

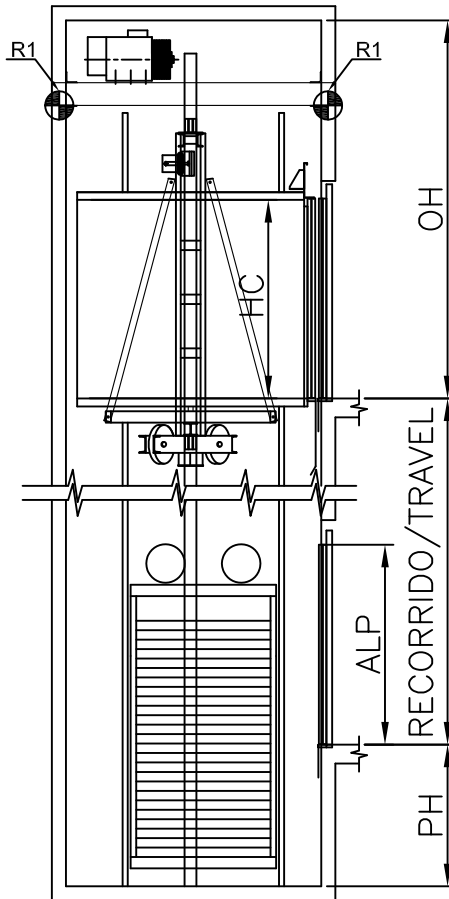

ESCALA/SCALE 1:40

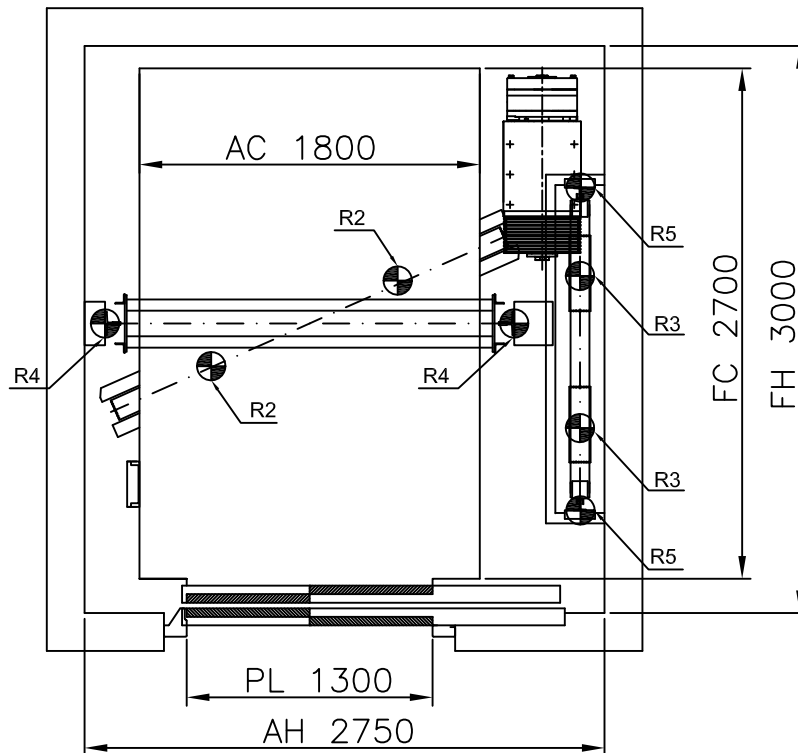

ACCIONES SOBRE EL HUECO / SHAFT REACTIONS

R1	CARGA SOBRE PARED / WALL LOAD	80000 N
R2	CARGA EN PUFFER CAB / CAR BUFFER LOAD	87000 N
R3	CARGA EN PUFFER CPSO / CTW BUFFER LOAD	62400 N
R4	CARGA EN GUÍA CAB / CAR GUIDE LOAD	48700 N
R5	CARGA EN GUÍA CPSO / CTW GUIDE LOAD	1650 N
	REACCION DE GUIAS Sx / GUIDES REACTIONS Sx	2187 N
	REACCION DE GUIAS Sy / GUIDES REACTIONS Sy	3500 N

MP3316 GO! "S"

2500 Kg	1.6 m/s
33 P.	GO!
FOSO/PIT	HUIDA/OVERHEAD
1500	4000



26 Kw