

ESCALA/SCALE 1:100

ESCALA/SCALE 1:40

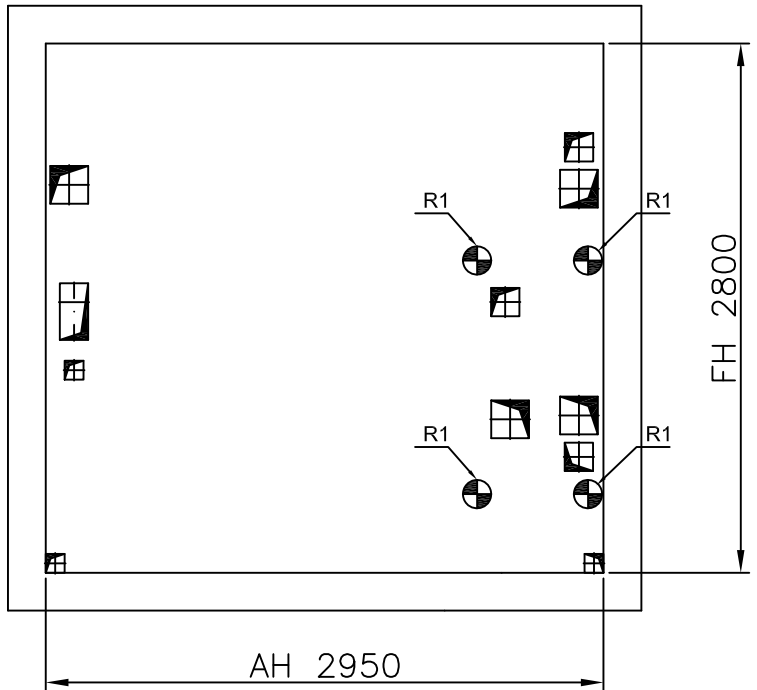

ESCALA/SCALE 1:40

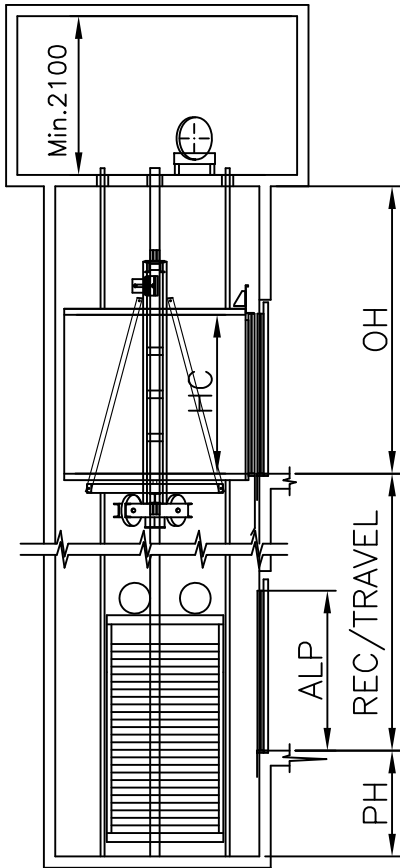
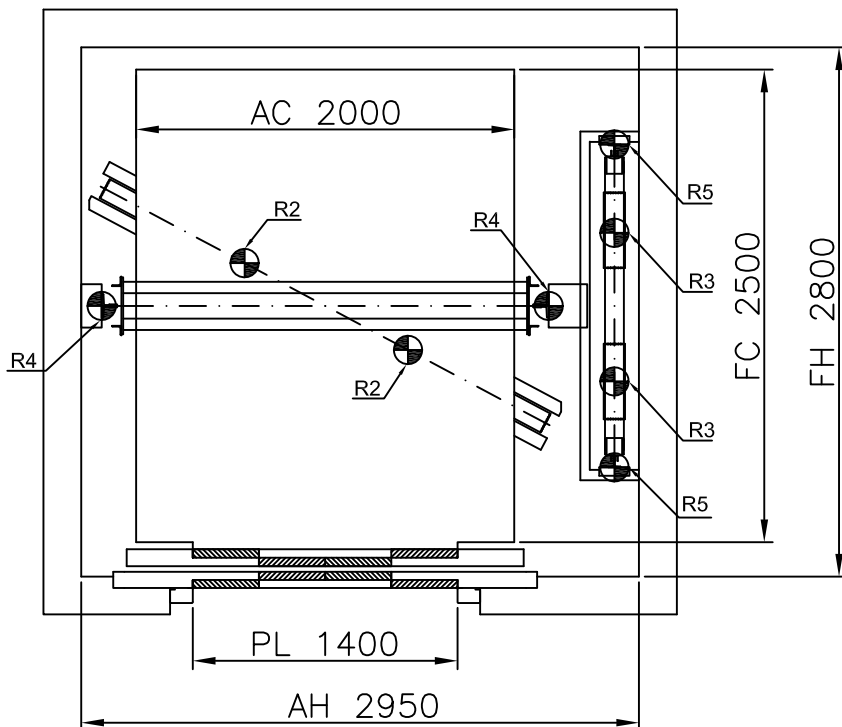

ACCIONES SOBRE EL HUECO / SHAFT REACTIONS

MP3310 GO! "C"

R1	CARGA SOBRE SOBRES LOSA / SLAB LOAD	58400 N
R2	CARGA EN PUFFER CAB / CAR BUFFER LOAD	87000 N
R3	CARGA EN PUFFER CPS0 / CTW BUFFER LOAD	62400 N
R4	CARGA EN GUÍA CAB / CAR GUIDE LOAD	48700 N
R5	CARGA EN GUÍA CPS0 / CTW GUIDE LOAD	1650 N
	REACCION DE GUIAS Sx / GUIDES REACTIONS Sx	2187 N
	REACCION DE GUIAS Sy / GUIDES REACTIONS Sy	3500 N

2500 Kg

1 m/s

33 P.

GO!

1400

3800

FOSO/PIT

HUIDA/OVERHEAD



16 Kw

ESCALA/SCALE 1:100

ESCALA/SCALE 1:40

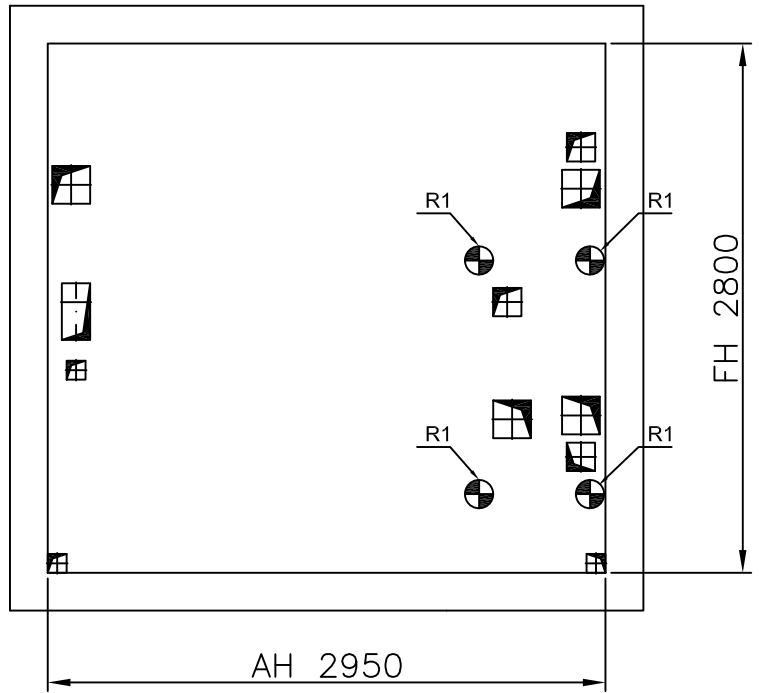
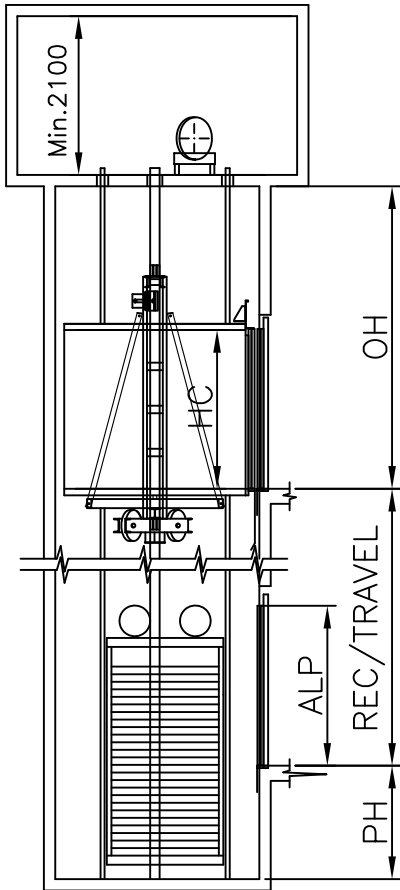

ESCALA/SCALE 1:40

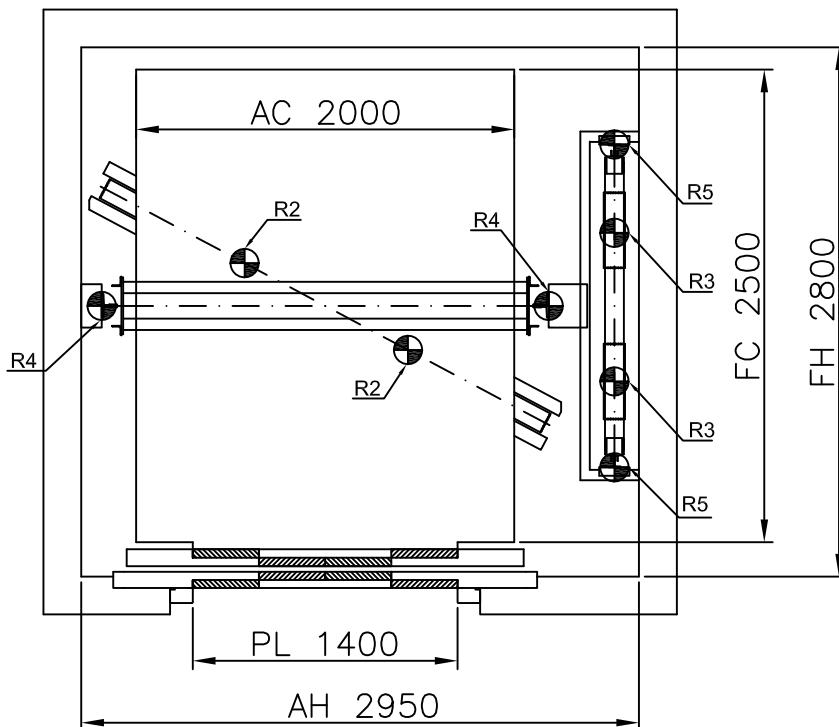

ACCIONES SOBRE EL HUECO / SHAFT REACTIONS

R1	CARGA SOBRE SOBRES LOSA / SLAB LOAD	58400 N
R2	CARGA EN PUFFER CAB / CAR BUFFER LOAD	87000 N
R3	CARGA EN PUFFER CPSO / CTW BUFFER LOAD	62400 N
R4	CARGA EN GUÍA CAB / CAR GUIDE LOAD	48700 N
R5	CARGA EN GUÍA CPSO / CTW GUIDE LOAD	1650 N
	REACCION DE GUIAS Sx / GUIDES REACTIONS Sx	2187 N
	REACCION DE GUIAS Sy / GUIDES REACTIONS Sy	3500 N

MP3316 GO! "C"

2500 Kg

1.6 m/s

33 P.

GO!

1500

4000

FOSO/PIT

HUIDA/OVERHEAD



26 Kw