

ESCALA/SCALE 1:80

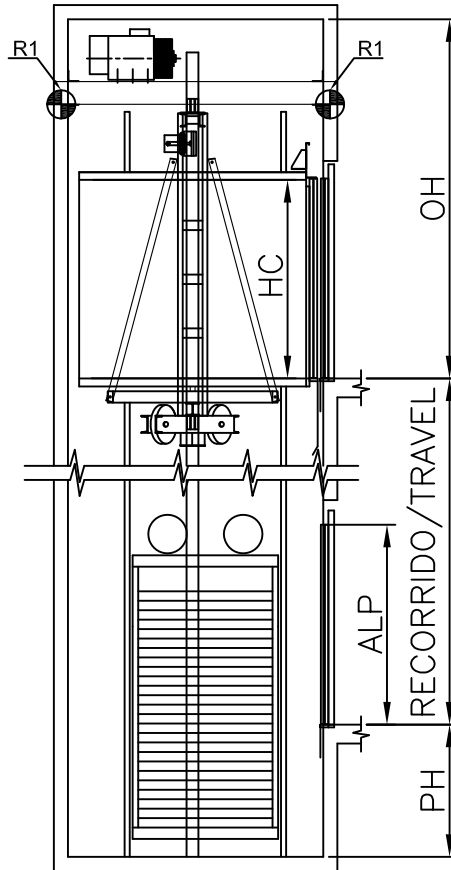

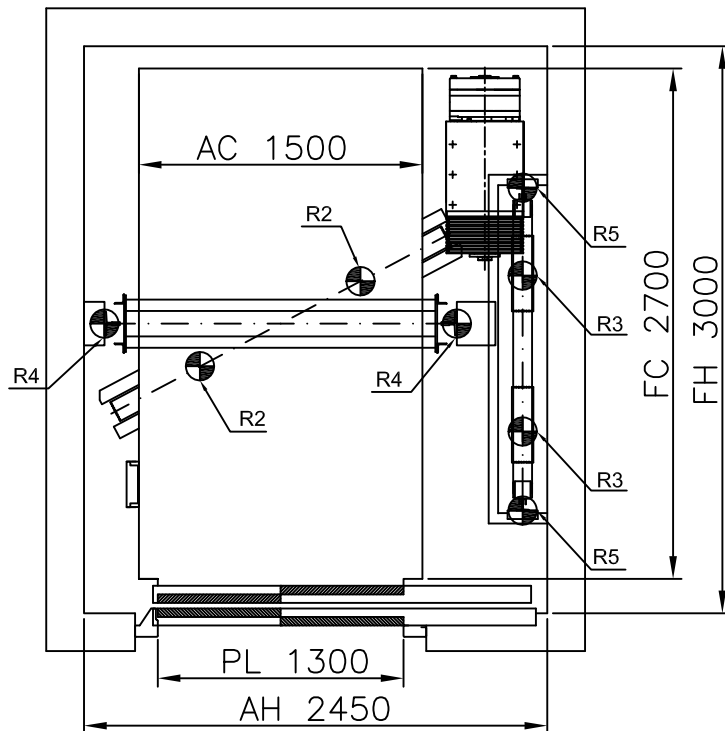

ESCALA/SCALE 1:40



ACCIONES SOBRE EL HUECO / SHAFT REACTIONS

MP2610 GO! "S"

R1	CARGA SOBRE PARED / WALL LOAD	70000 N	2000 Kg	1 m/s	
R2	CARGA EN PUFFER CAB / CAR BUFFER LOAD	74180 N			
R3	CARGA EN PUFFER CPS0 / CTW BUFFER LOAD	54540 N	26 P.	GO!	
R4	CARGA EN GUÍA CAB / CAR GUIDE LOAD	42340 N	FOSO/PIT	HUIDA/OVERHEAD	
R5	CARGA EN GUÍA CPS0 / CTW GUIDE LOAD	1650 N	1400	3800	
	REACCION DE GUIAS Sx / GUIDES REACTIONS Sx	1470 N			16 Kw
	REACCION DE GUIAS Sy / GUIDES REACTIONS Sy	2800 N			

ESCALA/SCALE 1:80

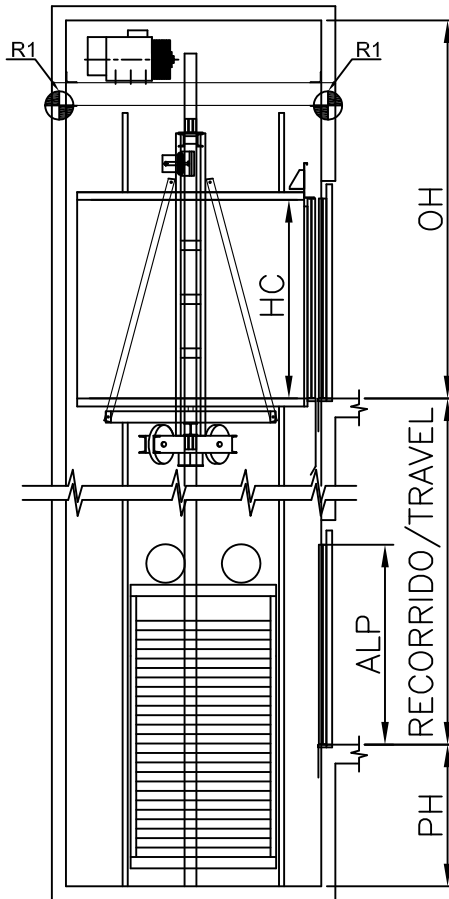

ESCALA/SCALE 1:40

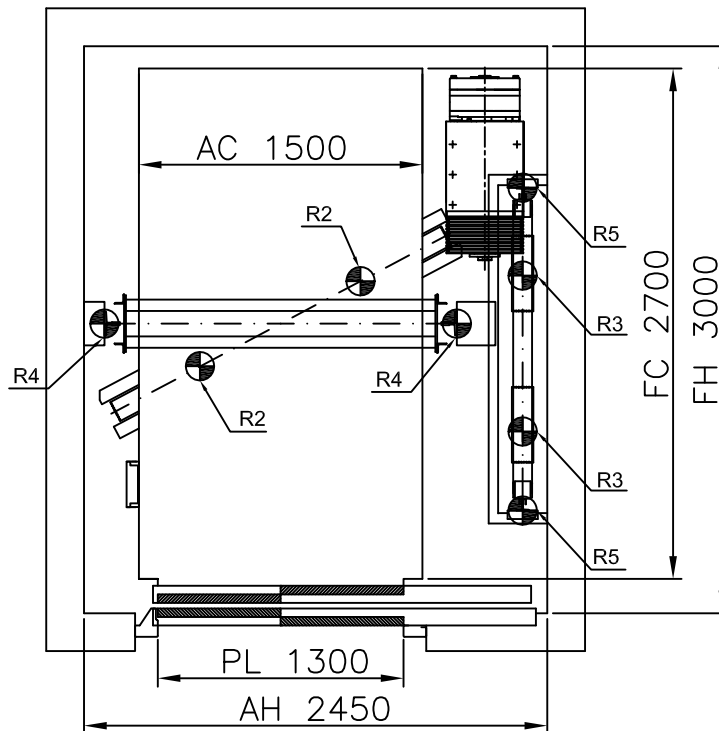

ACCIONES SOBRE EL HUECO / SHAFT REACTIONS

R1	CARGA SOBRE PARED / WALL LOAD	70000 N
R2	CARGA EN PUFFER CAB / CAR BUFFER LOAD	74180 N
R3	CARGA EN PUFFER CPSO / CTW BUFFER LOAD	54540 N
R4	CARGA EN GUÍA CAB / CAR GUIDE LOAD	42340 N
R5	CARGA EN GUÍA CPSO / CTW GUIDE LOAD	1650 N
	REACCION DE GUIAS Sx / GUIDES REACTIONS Sx	1470 N
	REACCION DE GUIAS Sy / GUIDES REACTIONS Sy	2800 N

MP2616 GO! "S"

2000 Kg	1.6 m/s
26 P.	GO!
FOSO/PIT	HUIDA/OVERHEAD
1500	4000



26 Kw