

ESCALA/SCALE 1:100

ESCALA/SCALE 1:40

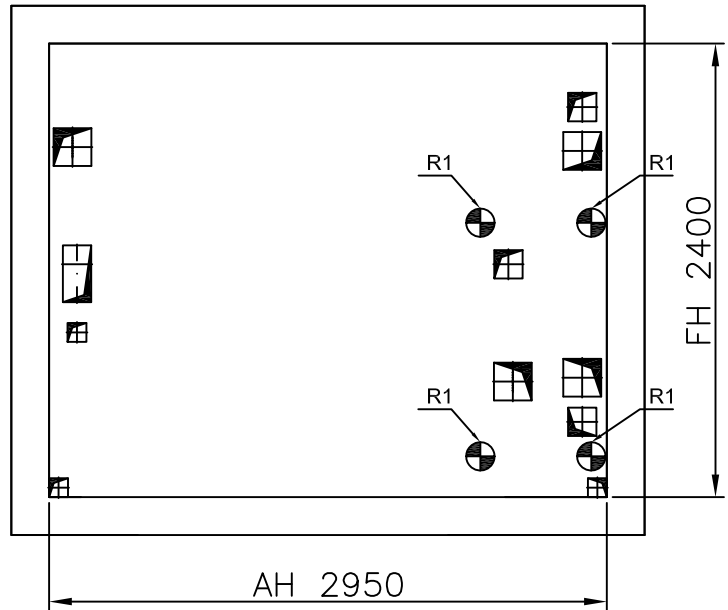

ESCALA/SCALE 1:40

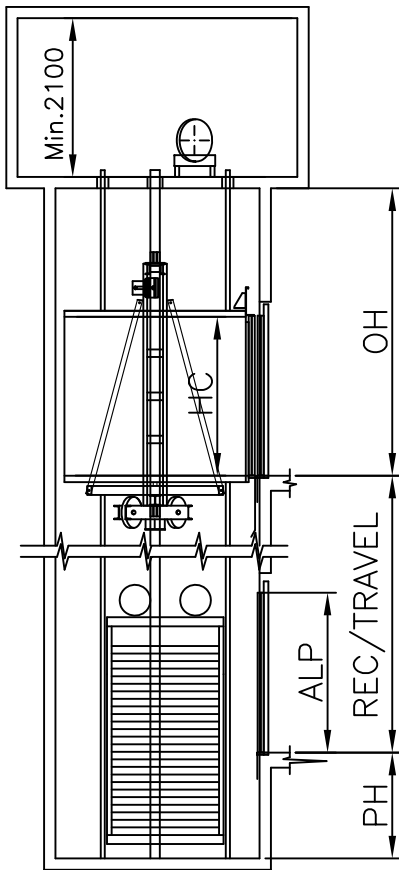
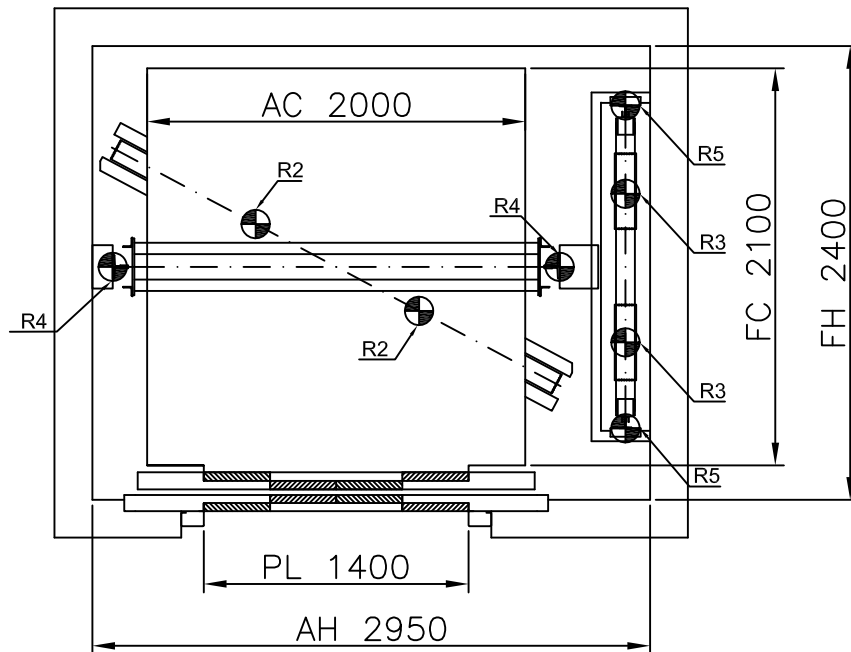

ACCIONES SOBRE EL HUECO

MP2610 GO! "C"

R1	CARGA SOBRE SOBRE LOSA / SLAB LOAD	51188 N
R2	CARGA EN PUFFER CAB / CAR BUFFER LOAD	74180 N
R3	CARGA EN PUFFER CPSO / CTW BUFFER LOAD	54540 N
R4	CARGA EN GUÍA CAB / CAR GUIDE LOAD	42340 N
R5	CARGA EN GUÍA CPSO / CTW GUIDE LOAD	1650 N
	REACCION DE GUIAS Sx / GUIDES REACTIONS Sx	1470 N
	REACCION DE GUIAS Sy / GUIDES REACTIONS Sy	2800 N

2000 Kg

1 m/s

26 P.

GO!

1400

3800

FOSO/PIT

HUIDA/OVERHEAD



16 Kw

ESCALA/SCALE 1:100

ESCALA/SCALE 1:40

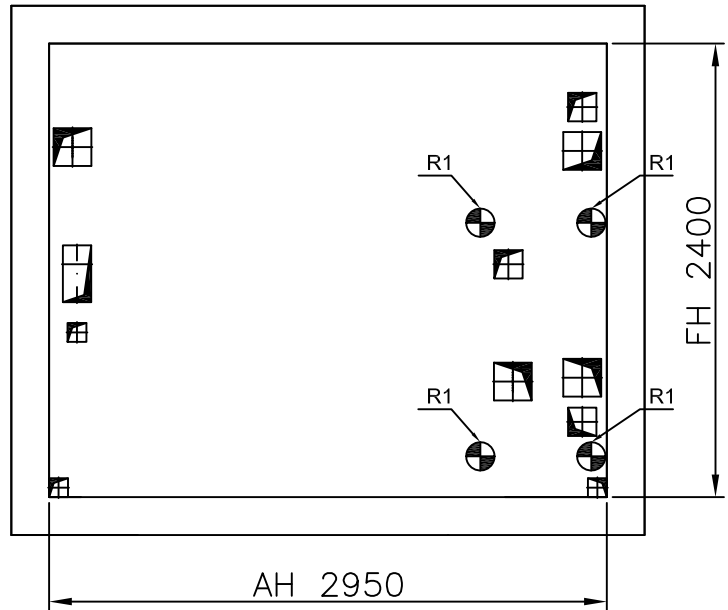
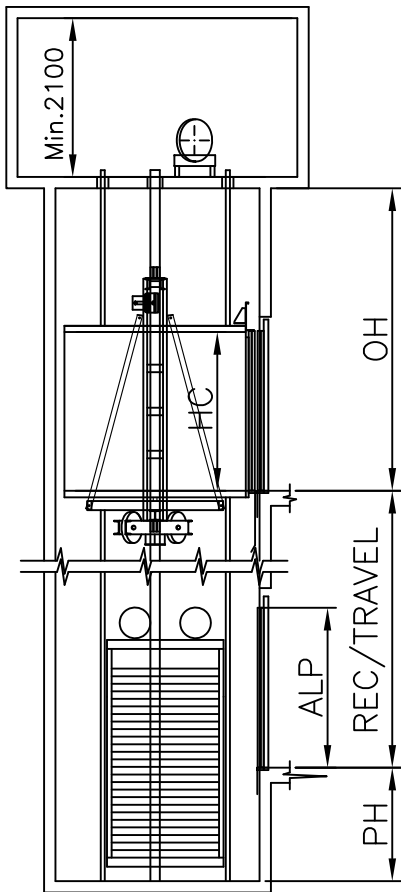

ESCALA/SCALE 1:40

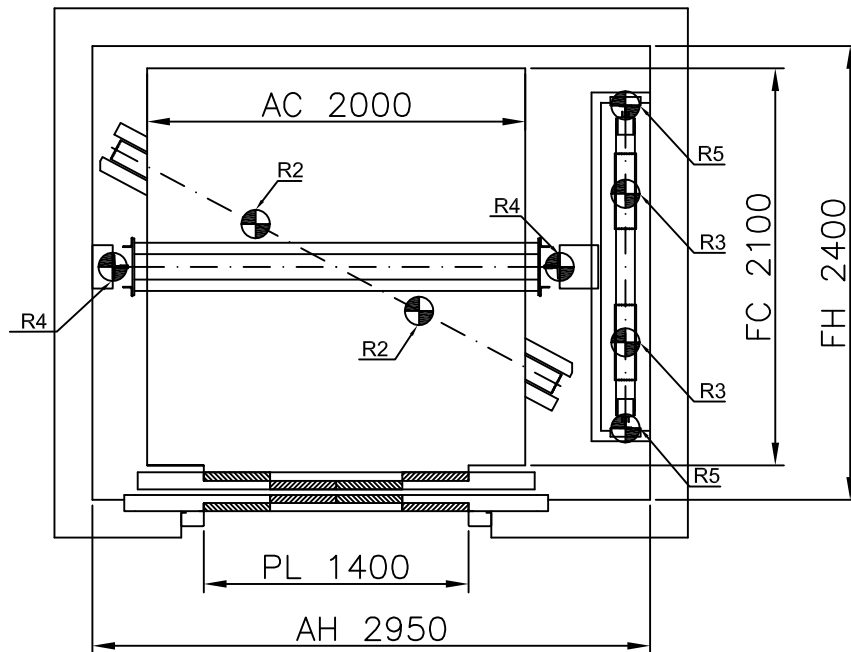

ACCIONES SOBRE EL HUECO

MP2616 GO! "C"

R1	CARGA SOBRE SOBRE LOSA / SLAB LOAD	51188 N
R2	CARGA EN PUFFER CAB / CAR BUFFER LOAD	74180 N
R3	CARGA EN PUFFER CPSO / CTW BUFFER LOAD	54540 N
R4	CARGA EN GUÍA CAB / CAR GUIDE LOAD	42340 N
R5	CARGA EN GUÍA CPSO / CTW GUIDE LOAD	1650 N
	REACCION DE GUIAS Sx / GUIDES REACTIONS Sx	1470 N
	REACCION DE GUIAS Sy / GUIDES REACTIONS Sy	2800 N

2000 Kg

1.6 m/s

26 P.

GO!

1500

4000

FOSO/PIT

HUIDA/OVERHEAD



26 Kw