

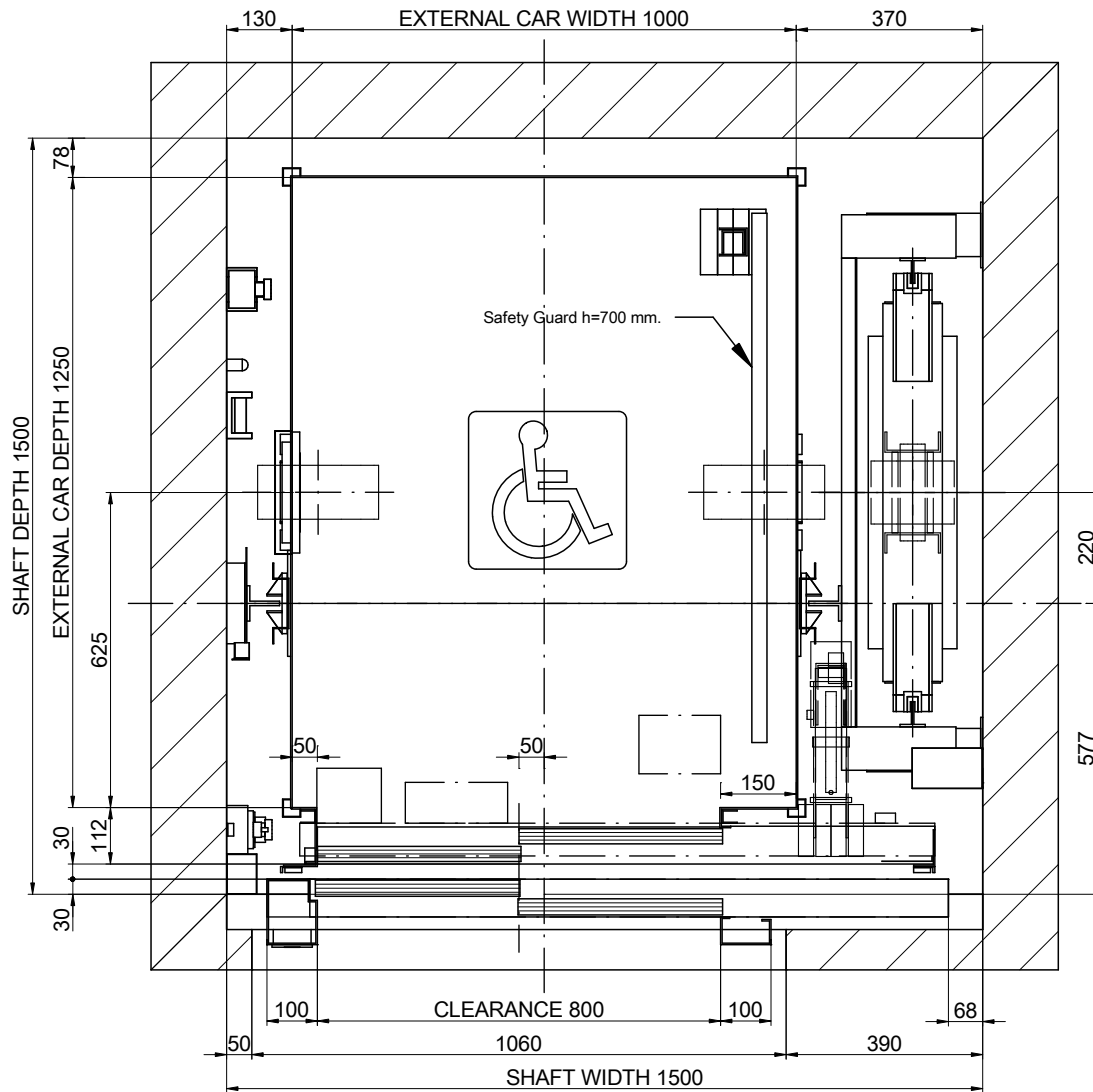

01-PLAN VIEW



| | | | | | |
|-------------------------|------|------|--------------------|---|---|
| DRAWING | DATE | REV. | SHEET | [*] Unbounded dimensions in drawings are indicative and not binding. REFERENCE: MPGO!EVOLUTION480ST2_EN |  |
| MP | 2017 | 00 | 1/8 | | |
| MODEL LIFT: | | | | CLIENT: | WORK SITUATION: |
| MP GO! EVOLUTION | | | | | |
| CAPACITY: [N° PERSONS] | | | 6 | MP LIFTS | |
| NOMINAL LOAD: [kg] | | | 480 | | |
| SPEED: [m/s] | | | 1 | | |
| FREQUENCY: [Hz] | | | 50 | | |
| TENSION: [V] | | | 380V [Three-phase] | | |

01B-PLAN VIEW

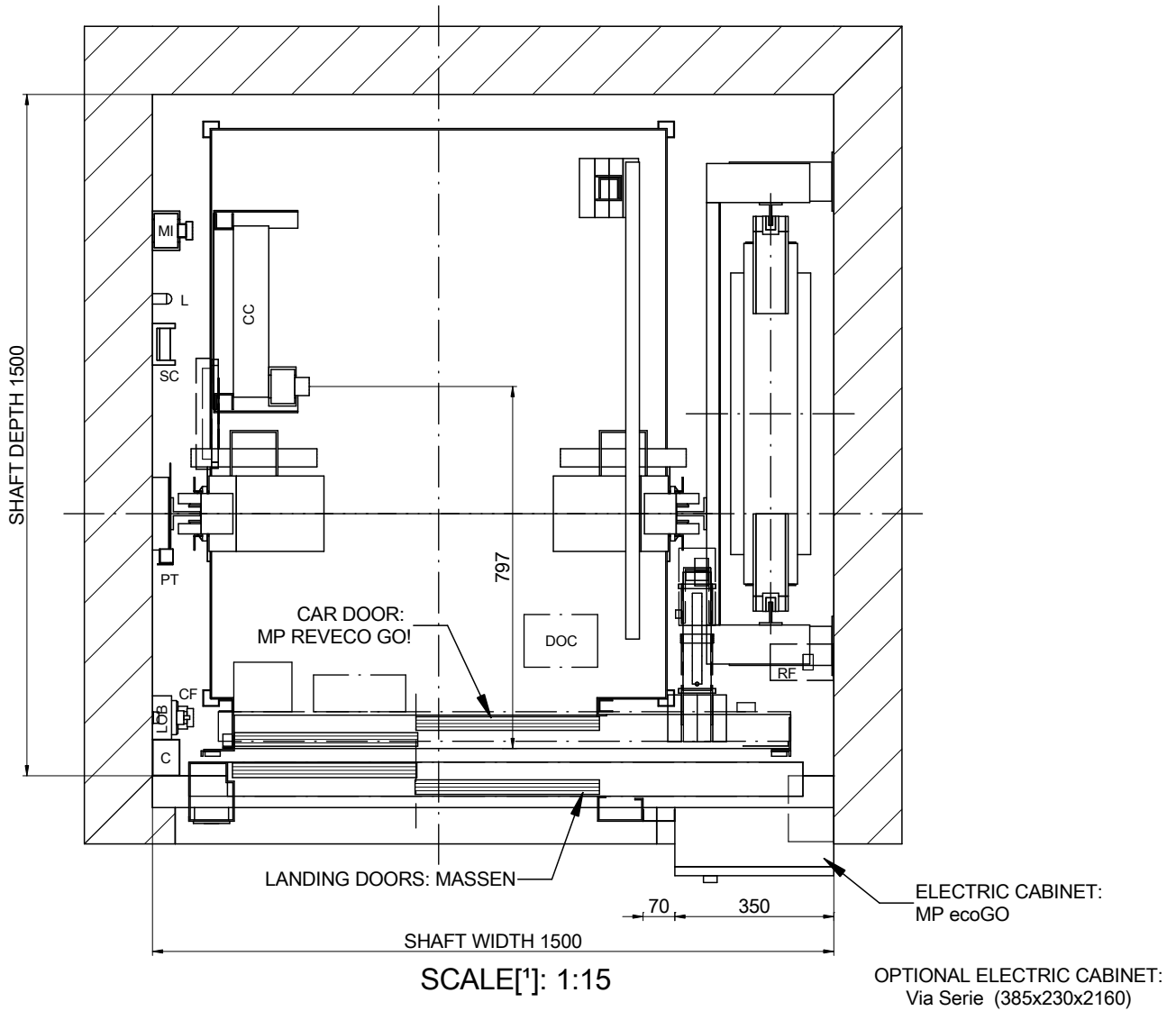

NOMENCLATURE

C: Wiring channel
 CC: Car ceiling connection box
 CF: Pit box
 CL: Shaft light switch
 DOC: Operator control box
 L: Lamp
 LOB: Pushbutton control board
 MI: Inspection control station
 PT: Fixed cam
 RF: Brake resistor
 ST: Stopping device
 SC: Travelling cable support

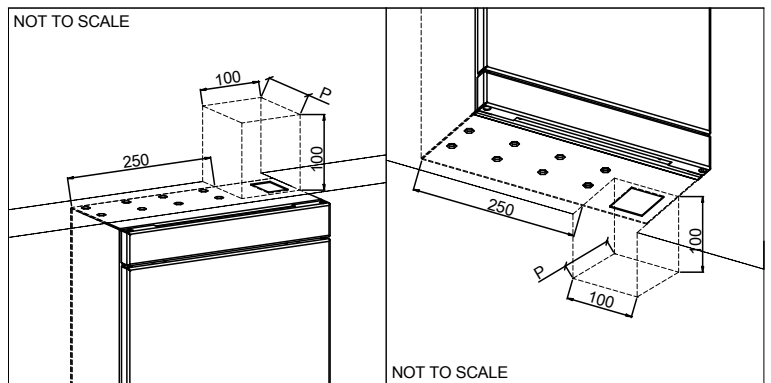

| | | | |
|-------------------------|--------------------|------|-------|
| DRAWING | DATE | REV. | SHEET |
| MP | 2017 | 00 | 2/8 |
| MODEL LIFT: | | | |
| MP GO! EVOLUTION | | | |
| CAPACITY: [N° PERSONS] | 6 | | |
| NOMINAL LOAD: [kg] | 480 | | |
| SPEED: [m/s] | 1 | | |
| FREQUENCY: [Hz] | 50 | | |
| TENSION: [V] | 380V [Three-phase] | | |

[*] Unbounded dimensions in drawings are indicative and not binding.

REFERENCE:
 MPGO!EVOLUTION480ST2_EN

CLIENT:
 WORK SITUATION:

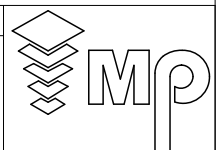

MP LIFTS

02-SIDE VERTICAL SECTION

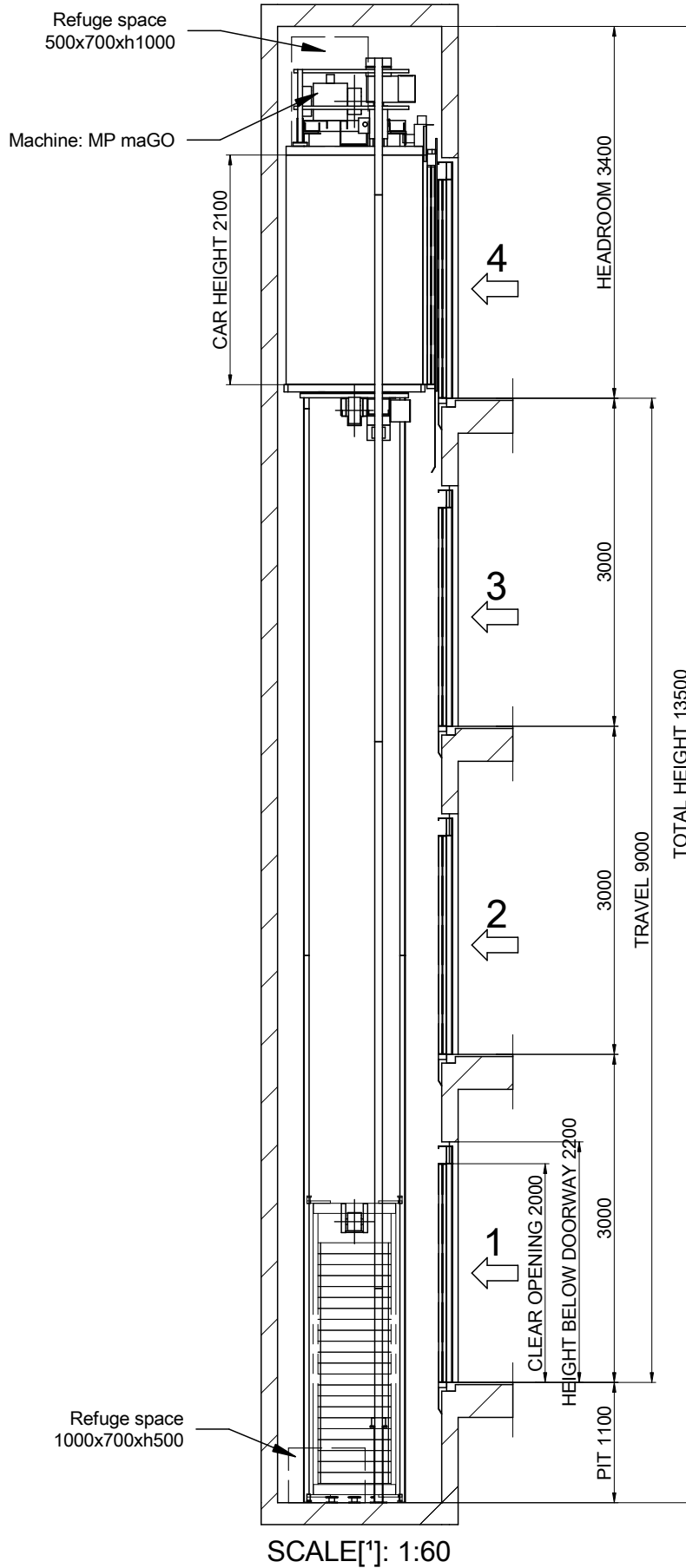

| | | | | | |
|--|--|-------------------------|----|------|-------|
| DRAWING | | DATE | | REV. | SHEET |
| | | 2017 | 00 | 3/8 | |
| MP | | MODEL LIFT: | | | |
| MP GOI EVOLUTION | | MPGOIEVOLUTION480ST2_EN | | | |
| CAPACITY: [N° PERSONS] | | 6 | | | |
| NOMINAL LOAD: [kg] | | 480 | | | |
| SPEED: [m/s] | | 1 | | | |
| FREQUENCY: [Hz] | | 50 | | | |
| TENSION: [V] | | 380V [Three-phase] | | | |
| <p>[*] Unbounded dimensions in drawings are indicative and not binding.</p> <p>REFERENCE: MPGOIEVOLUTION480ST2_EN</p> <p>CLIENT: WORK SITUATION:</p> | | | | | |
| MP LIFTS | | | | | |

Flat and levelled floor, protected against water leaking. [EN81-20:2014 5.2.1.9]
 Foresee pit access device [EN81-20:2014 5.2.2.4]
 Stop device [EN81-20:2014 5.2.1.5.1. a]
 Inspection control station. [EN81-20:2014 5.2.1.5.1. b]
 Power supply [EN81-20:2014 5.2.1.5.1. c]
 Light switch commuted with the cabinet. [EN81-20:2014 5.2.1.5.1. d]



03B-FIXING DETAILS IN HEADROOM

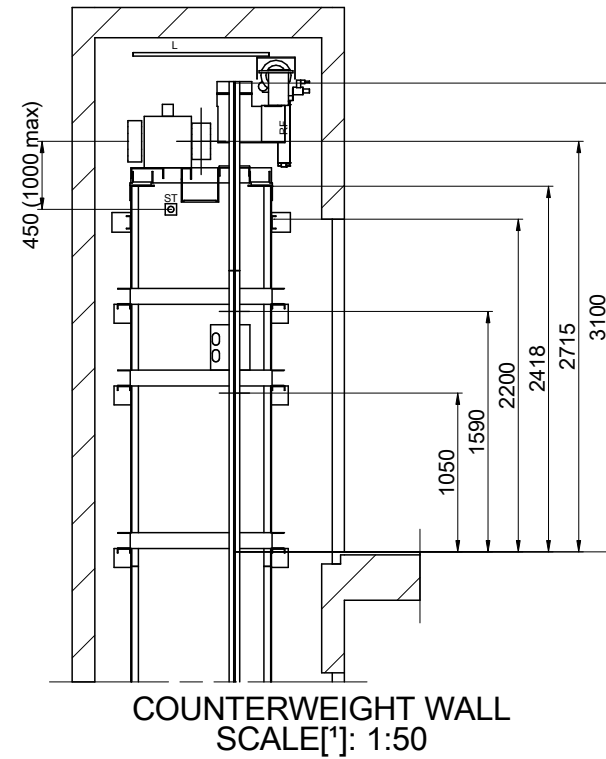
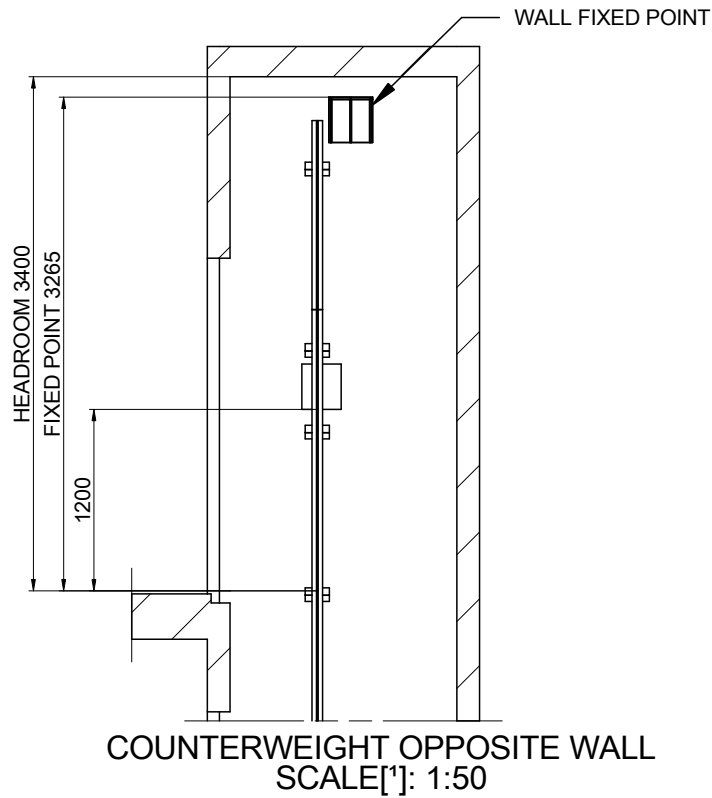

| DRAWING | DATE | REV. | SHEET |
|-------------------------|------|--------------------|-------|
| MP | 2017 | 00 | 4/8 |
| MODEL LIFT: | | | |
| MP GO! EVOLUTION | | | |
| CAPACITY: [N° PERSONS] | | | 6 |
| NOMINAL LOAD: [kg] | | | 480 |
| SPEED: [m/s] | | | 1 |
| FREQUENCY: [Hz] | | | 50 |
| TENSION: [V] | | 380V [Three-phase] | |

[*] Unbounded dimensions in drawings are indicative and not binding.

REFERENCE:
MPGO!EVOLUTION480ST2_EN

CLIENT:
WORK SITUATION:



MP LIFTS

04-BEAM AND LIFTING HOOKS

POSITION OF REMOVABLE LIFTING HOOKS ABLE TO SUPPORT
1000 kg EACH ONE SUPPLIED BY CONSTRUCTOR
(RECOMMENDED POSITION LOADHOOKS)

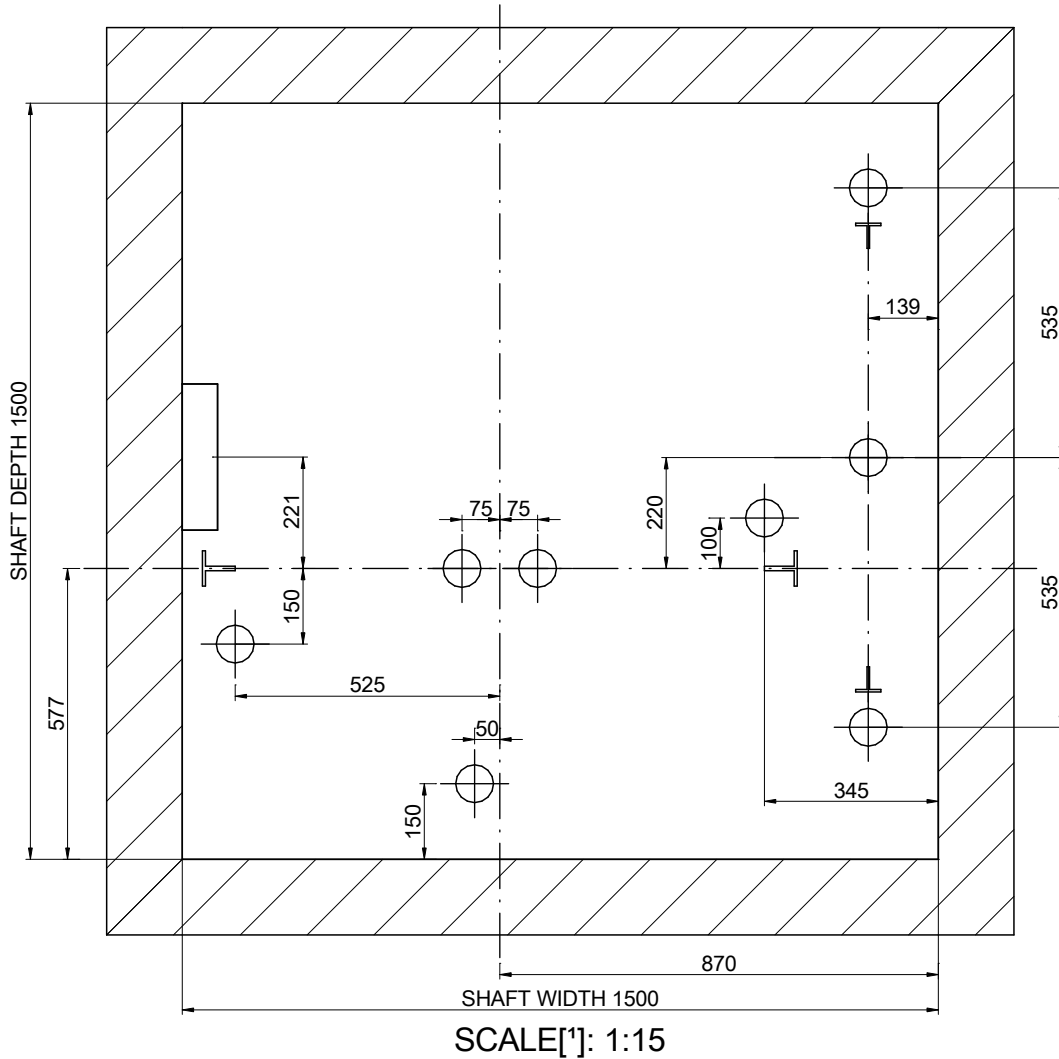

| | | | | | |
|-------------------------|------|------|--------------------|--|---|
| DRAWING | DATE | REV. | SHEET | [*] Unbounded dimensions in drawings are indicative and not binding. |  |
| MP | 2017 | 00 | 5/8 | REFERENCE: MPGO!EVOLUTION480ST2_EN | |
| MODEL LIFT: | | | | CLIENT: | <p>MP LIFTS</p> |
| MP GO! EVOLUTION | | | | WORK SITUATION: | |
| CAPACITY: [N° PERSONS] | | | 6 | | |
| NOMINAL LOAD: [kg] | | | 480 | | |
| SPEED: [m/s] | | | 1 | | |
| FREQUENCY: [Hz] | | | 50 | | |
| TENSION: [V] | | | 380V [Three-phase] | | |

05-PIT LAYOUT

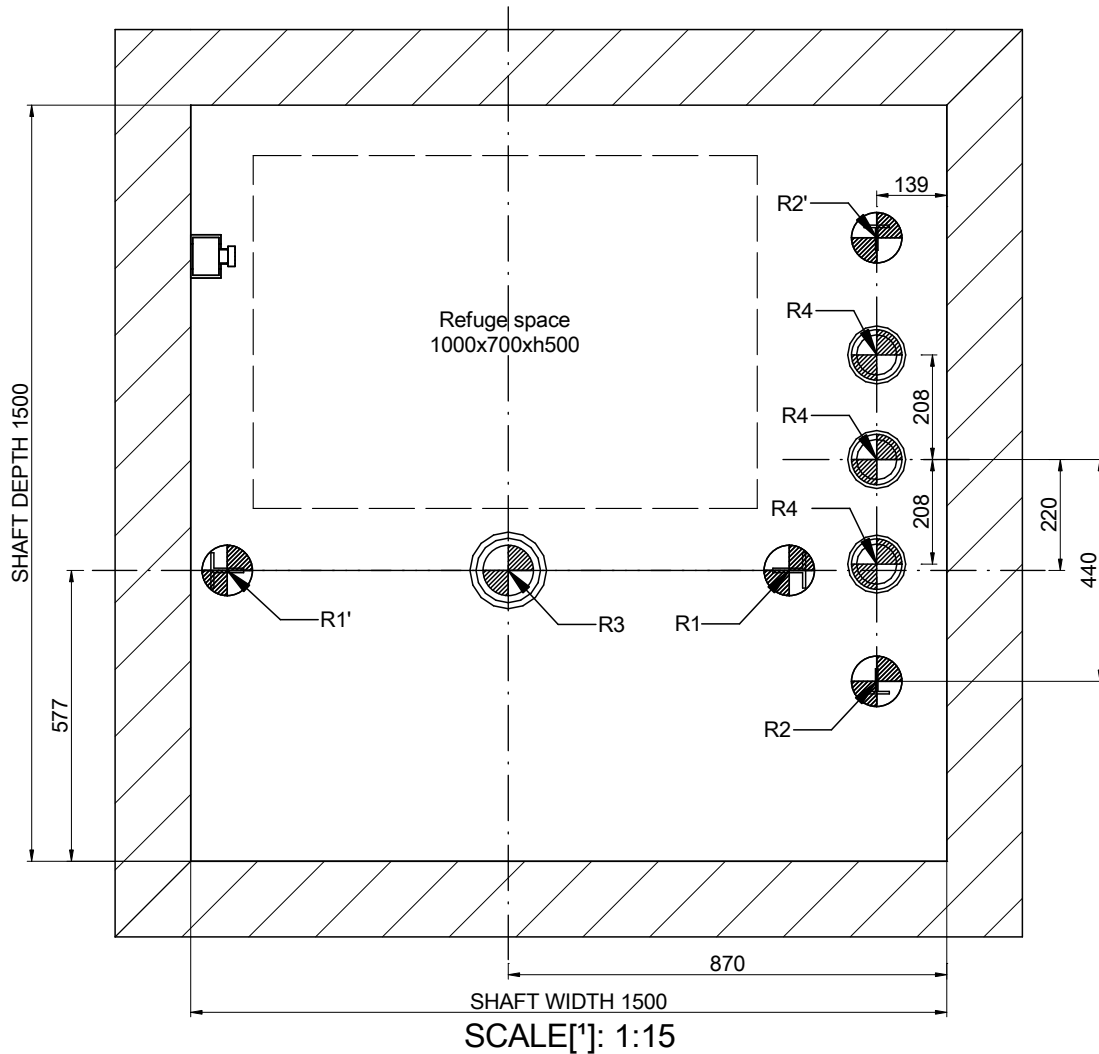

| REACTIONS [N] [max.] | | | |
|----------------------|-------|-----|-------|
| R1 | 28000 | R2 | 20500 |
| R1' | 25000 | R2' | 21000 |
| R3 | 57000 | R4 | 16000 |
| N | 1800 | T | 850 |



| DRAWING | DATE | REV. | SHEET | [*] Unbounded dimensions in drawings are indicative and not binding. |
|------------------------|------|--------------------|-------|--|
| MP | 2017 | 00 | 6/8 | REFERENCE: MPGO!EVOLUTION480ST2_EN |
| MODEL LIFT: | | | | MP |
| MP GO! EVOLUTION | | | | |
| CAPACITY: [N° PERSONS] | | 6 | | CLIENT: WORK SITUATION: |
| NOMINAL LOAD: [kg] | | 480 | | |
| SPEED: [m/s] | | 1 | | |
| FREQUENCY: [Hz] | | 50 | | |
| TENSION: [V] | | 380V [Three-phase] | | |
| | | | | MP LIFTS |

06-DOOR HOLE DETAIL

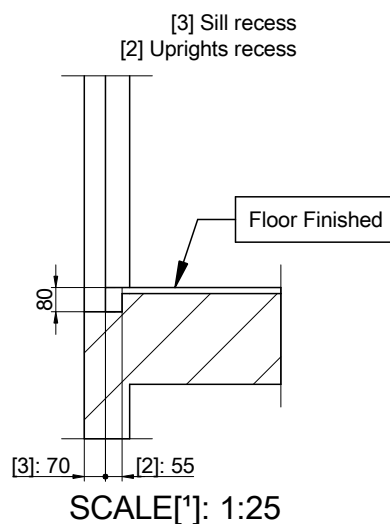
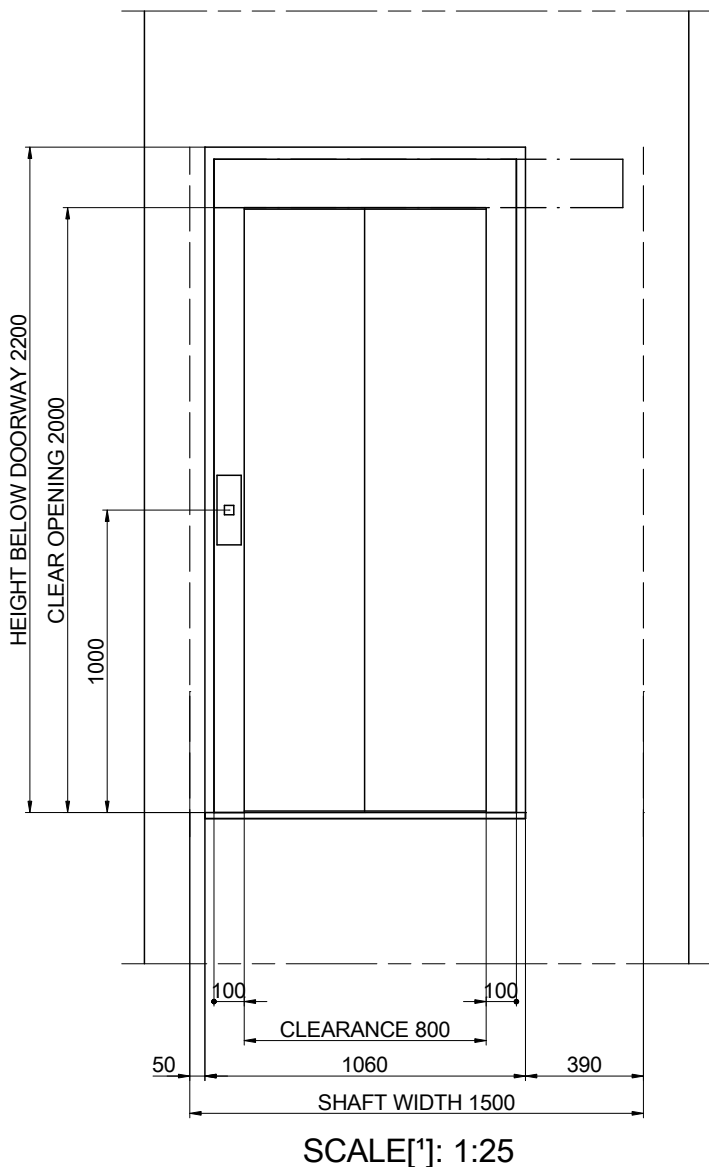

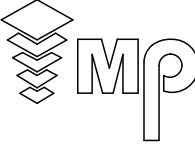
| | | | | | |
|------------------------|------|------|--------------------|--|---|
| DRAWING | DATE | REV. | SHEET | [*] Unbounded dimensions in drawings are indicative and not binding. |  |
| MP | 2017 | 00 | 7/8 | REFERENCE: MPGO!EVOLUTION480ST2_EN | |
| MODEL LIFT: | | | | CLIENT: WORK SITUATION: | |
| MP GO! EVOLUTION | | | | | |
| CAPACITY: [N° PERSONS] | | | 6 | | |
| NOMINAL LOAD: [kg] | | | 480 | | |
| SPEED: [m/s] | | | 1 | | |
| FREQUENCY: [Hz] | | | 50 | | |
| TENSION: [V] | | | 380V [Three-phase] | MP LIFTS | |

07-HEADROOM

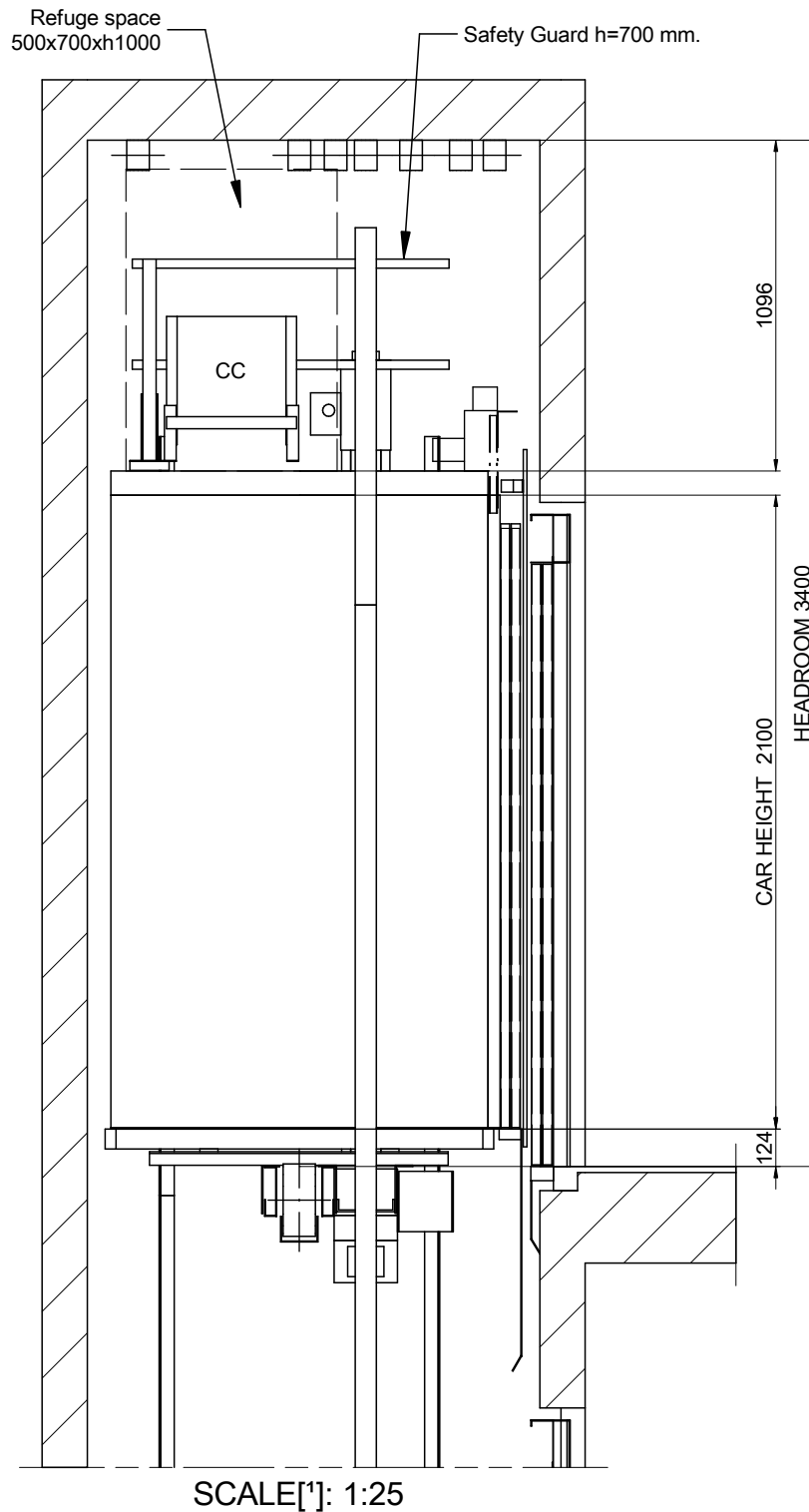

| | | | | | |
|-------------------------|------|------|--------------------|--|---|
| DRAWING | DATE | REV. | SHEET | [*] Unbounded dimensions in drawings are indicative and not binding. |  |
| MP | 2017 | 00 | 8/8 | REFERENCE: MPGO!EVOLUTION480ST2_EN | |
| MODEL LIFT: | | | | CLIENT: | <p>MP LIFTS</p> |
| MP GO! EVOLUTION | | | | WORK SITUATION: | |
| CAPACITY: [N° PERSONS] | | | 6 | | |
| NOMINAL LOAD: [kg] | | | 480 | | |
| SPEED: [m/s] | | | 1 | | |
| FREQUENCY: [Hz] | | | 50 | | |
| TENSION: [V] | | | 380V [Three-phase] | | |