

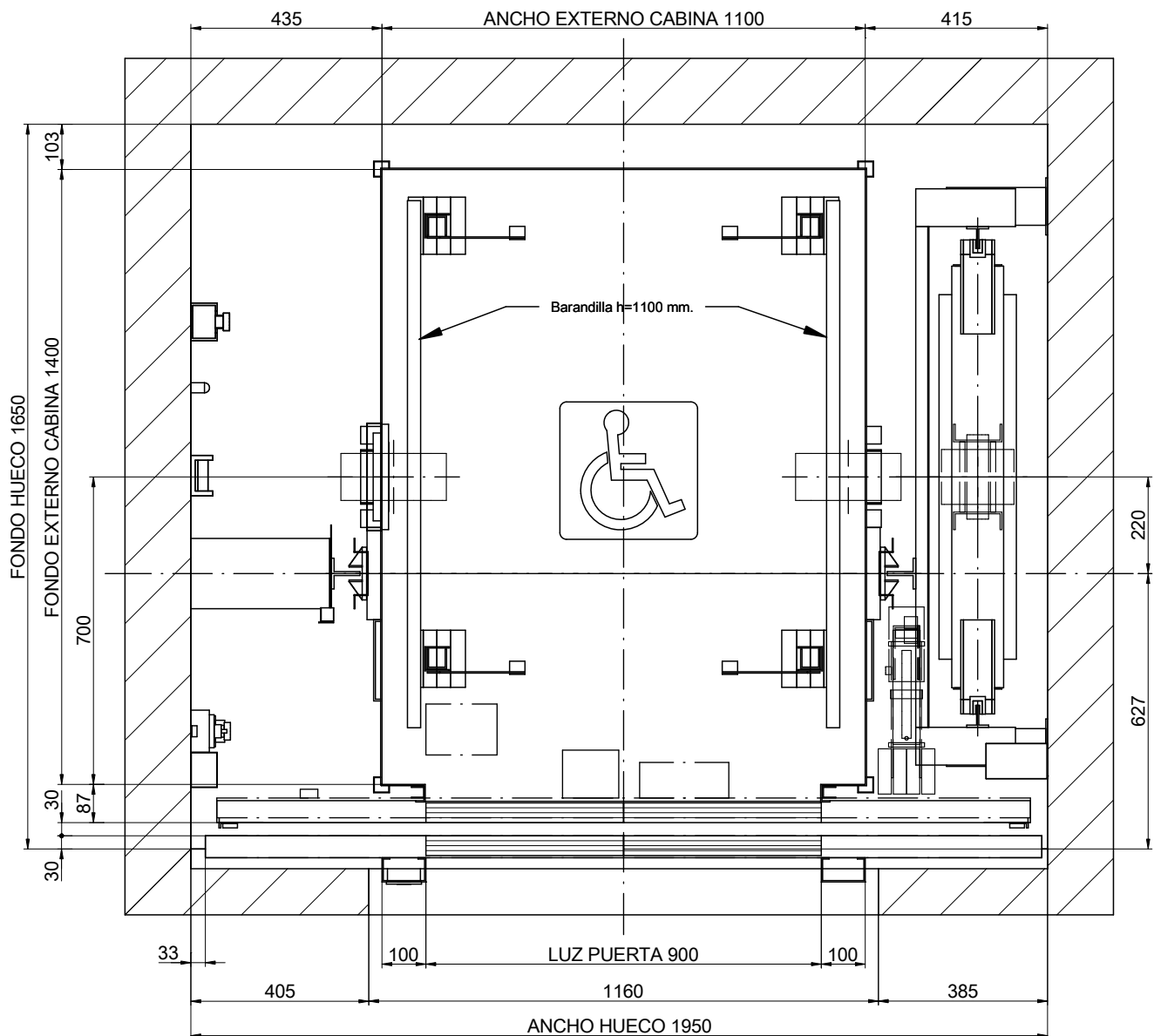

01-PLANTA



ESCALA[*]: 1:15

DIBUJADO	FECHA	REV.	HOJA	[*] Las dimensiones no acotadas en el plano son indicativas y no vinculantes.	
MP	2017	00	1/8		
MODELO ASCENSOR:				REFERENCIA:	
MP GO! EVOLUTION				MPGO!EVOLUTION630SC2_ES	
CAPACIDAD: [Nº PERSONAS]				8	CLIENTE:
CARGA UTIL: [kg]				630	SITUACION OBRA:
VELOCIDAD: [m/s]				1	
FRECUENCIA: [Hz]				50	
TENSION: [V]				380V [Trifásica]	MP ASCENSORES

01B-PLANTA

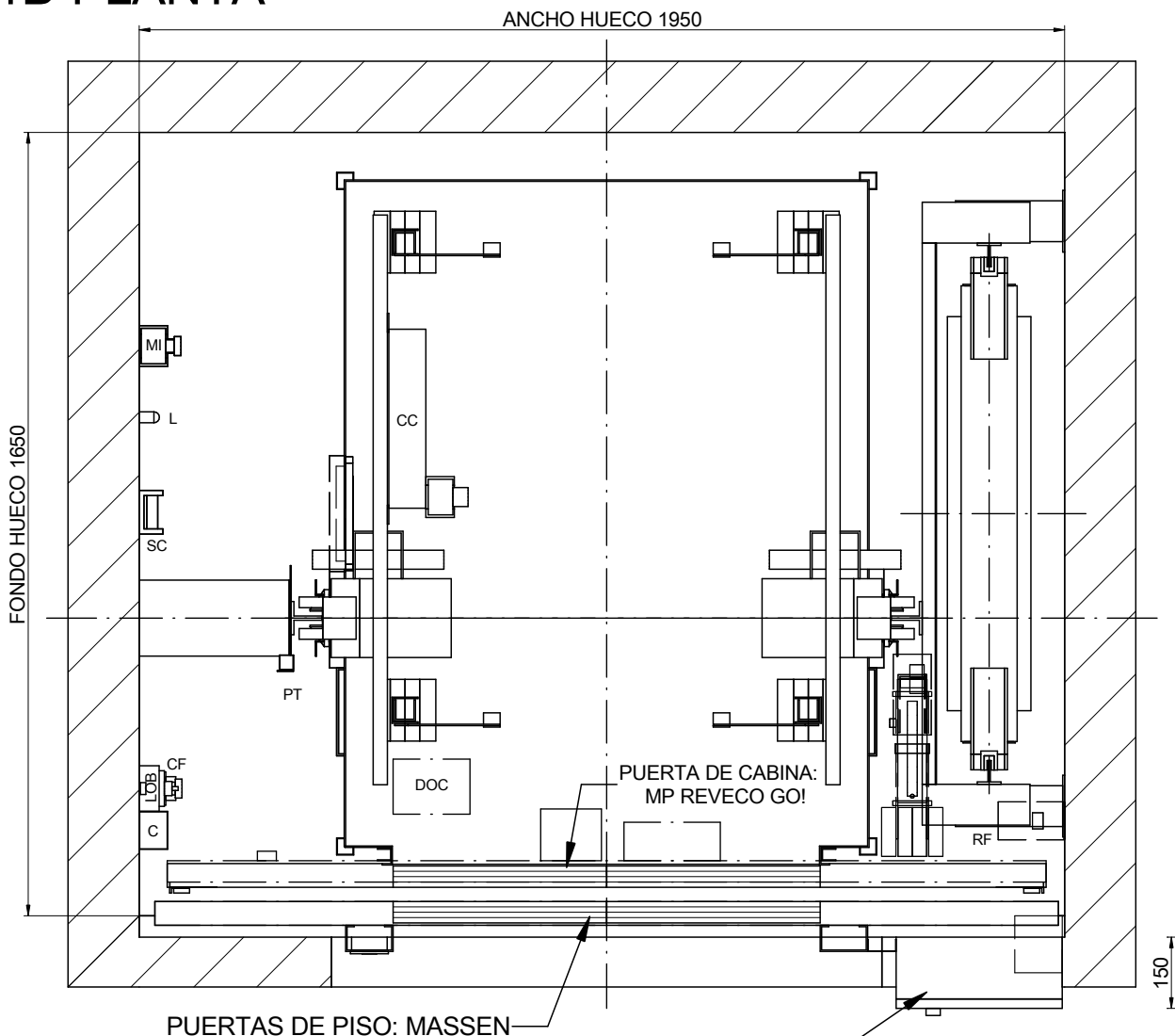

ESCALA[*]: 1:15

ARMARIO ELECTRICO:
MP ecoGO

OPCION ARMARIO ELECTRICO:
Via Serie (385x230x2160)

NOMENCLATURA

- C: Canaleta
- CC: Caja conexiones techo cabina
- CF: Caja foso
- CL: Conmutador Luz Hueco
- DOC: Caja Control Operador
- L: Luminaria
- LOB: Placa Control Botoneras
- MI: Mando Inspección
- PT: Patín
- RF: Resistencia Frenado
- ST: Dispositivo parada
- SC: Soporte cuerda maniobra

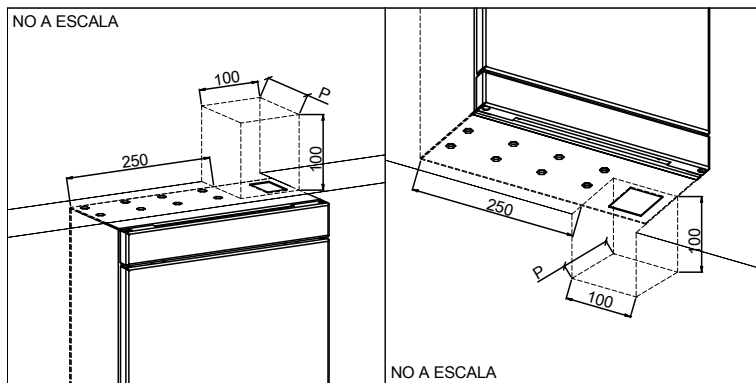

DIBUJADO	FECHA	REV.	HOJA
MP	2017	00	2/8
MODELO ASCENSOR:			
MP GO! EVOLUTION			
CAPACIDAD: [Nº PERSONAS]		8	
CARGA UTIL: [kg]		630	
VELOCIDAD: [m/s]		1	
FRECUENCIA: [Hz]		50	
TENSION: [V]		380V [Trifásica]	

[*] Las dimensiones no acotadas en el plano son indicativas y no vinculantes.

REFERENCIA:
MPGO!EVOLUTION630SC2_ES

CLIENTE:
SITUACION OBRA:

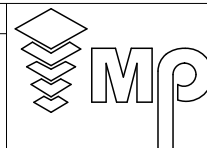

MP ASCENSORES

02-ALZADO LATERAL

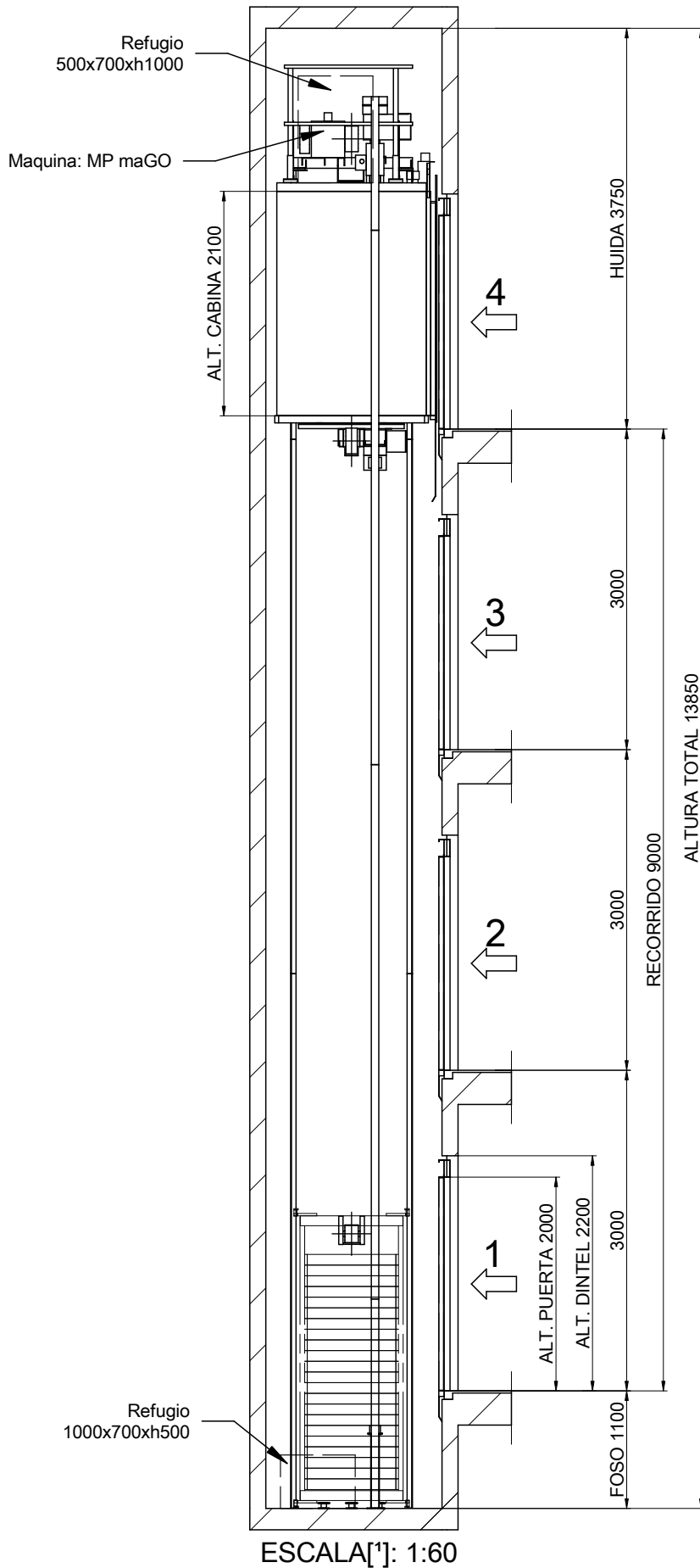

DIBUJADO		FECHA	REV.	HOJA	[*] Las dimensiones no acotadas en el plano son indicativas y no vinculantes.
MP	2017	00	3/8	REFERENCIA: MPGOIEVOLUTION630SC2_ES	
MODELO ASCENSOR:					CLIENTE: SITUACION OBRA:
MP GOI EVOLUTION					
CAPACIDAD: [N° PERSONAS]		8			
CARGA UTIL: [kg]		630			
VELOCIDAD: [m/s]		1			
FRECUENCIA: [Hz]		50			
TENSION: [V]		380V [Trifásica]			

Foso liso y a nivel protegido de infiltraciones de agua.
[EN81-20:2014 5.2.1.9]
Prever dispositivo de acceso.
[EN81-20:2014 5.2.2.4]
Dispositivo de parada.
[EN81-20:2014 5.2.1.5.1. a]
Estación de control de inspección.
[EN81-20:2014 5.2.1.5.1 b]
Toma de corriente.
[EN81-20:2014 5.2.1.5.1. c]
Interruptor de alumbrado, conmutado con el armario.
[EN81-20:2014 5.2.1.5.1. d]



MP ASCENSORES

03B-DETALLES DE FIJACION EN LA HUIDA

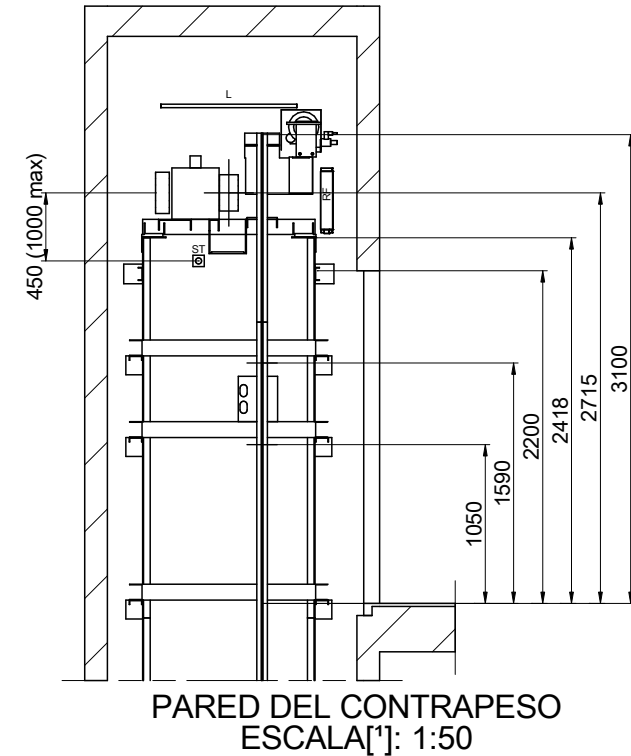
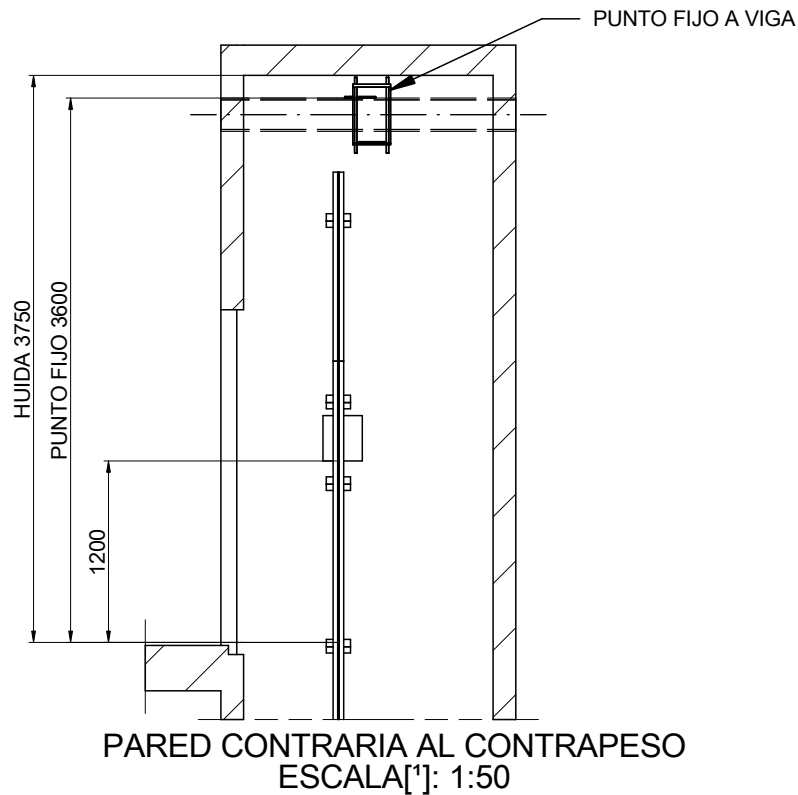

DIBUJADO	FECHA	REV.	HOJA
MP	2017	00	4/8
MODELO ASCENSOR:			
MP GO! EVOLUTION			
CAPACIDAD: [N° PERSONAS]		8	
CARGA UTIL: [kg]		630	
VELOCIDAD: [m/s]		1	
FRECUENCIA: [Hz]		50	
TENSION: [V]		380V [Trifásica]	

[*] Las dimensiones no acotadas en el plano son indicativas y no vinculantes.

REFERENCIA:
MPGO!EVOLUTION630SC2_ES

CLIENTE:
SITUACION OBRA:

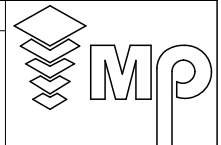

MP ASCENSORES

04-VIGA Y GANCHOS DE MONTAJE

POSICION DE LOS GANCHOS DESMONTABLES CAPACES DE SOPORTAR
1000 kg CADA UNO A SUMINISTRAR POR EL CONSTRUCTOR
(POSICION RECOMENDADA GANCHOS DE MONTAJE)

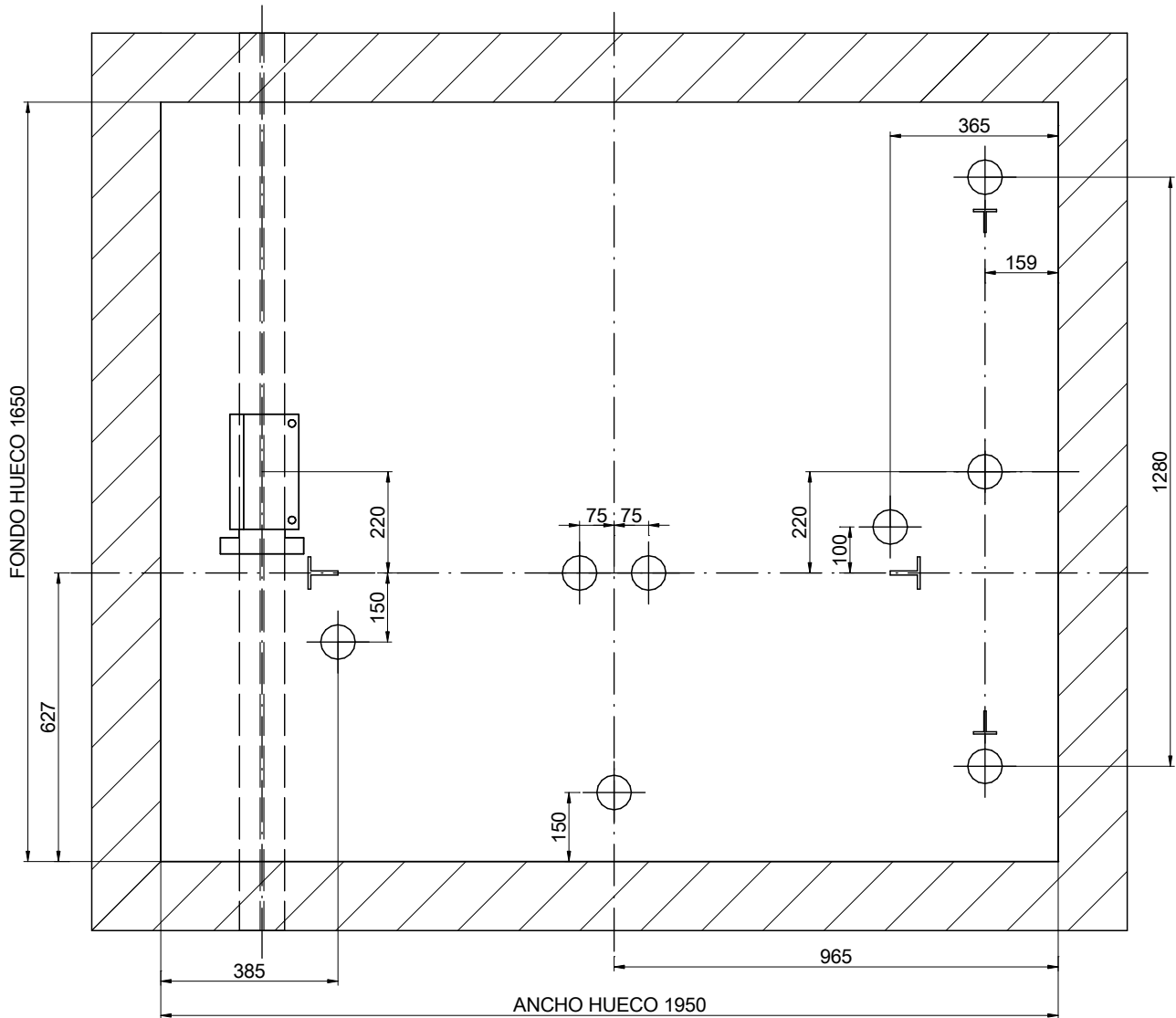

ESCALA[*]: 1:15

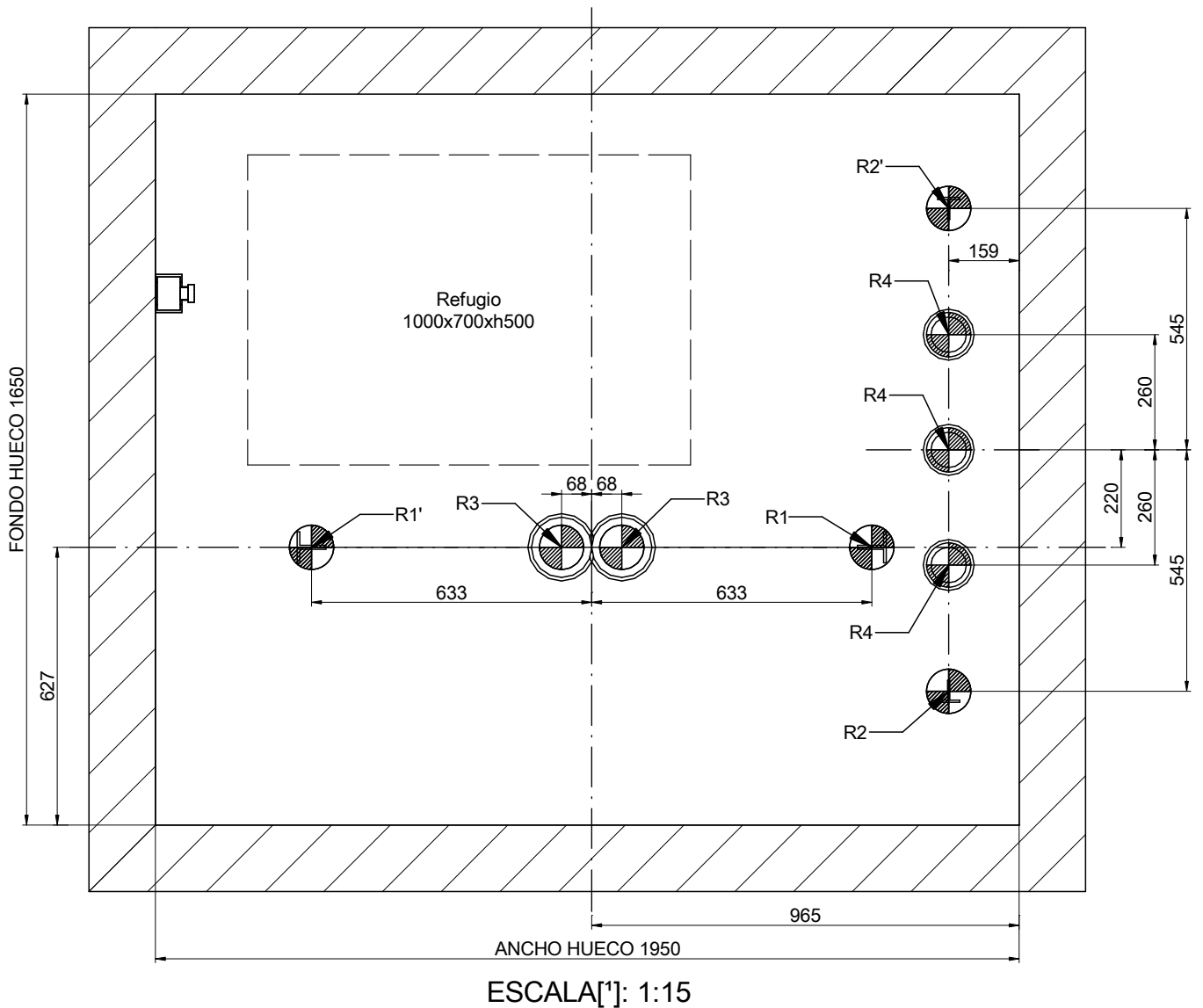

DIBUJADO	FECHA	REV.	HOJA	[*] Las dimensiones no acotadas en el plano son indicativas y no vinculantes.	
MP	2017	00	5/8	REFERENCIA: MPGO!EVOLUTION630SC2_ES	
MODELO ASCENSOR:				CLIENTE: SITUACION OBRA:	
MP GO! EVOLUTION					
CAPACIDAD: [N° PERSONAS]			8		
CARGA UTIL: [kg]			630		
VELOCIDAD: [m/s]			1		
FRECUENCIA: [Hz]			50		
TENSION: [V]		380V [Trifásica]		MP ASCENSORES	

05-PLANTA DE FOSO





REACCIONES [N] [max.]			
R1	30000	R2	22000
R1'	26000	R2'	23000
R3	31500	R4	17000
N	2000	T	1100



DIBUJADO	FECHA	REV.	HOJA	[*] Las dimensiones no acotadas en el plano son indicativas y no vinculantes.	
MP	2017	00	6/8		
MODELO ASCENSOR:				REFERENCIA:	
MP GO! EVOLUTION				MPGO!EVOLUTION630SC2_ES	
CAPACIDAD: [Nº PERSONAS]				8	CLIENTE: SITUACION OBRA:
CARGA UTIL: [kg]				630	
VELOCIDAD: [m/s]				1	
FRECUENCIA: [Hz]				50	
TENSION: [V]				380V [Trifásica]	
MP ASCENSORES					

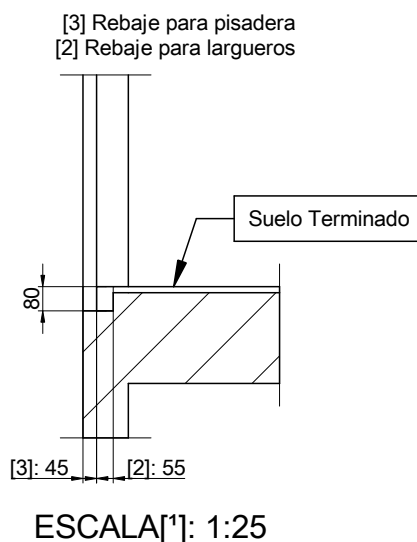
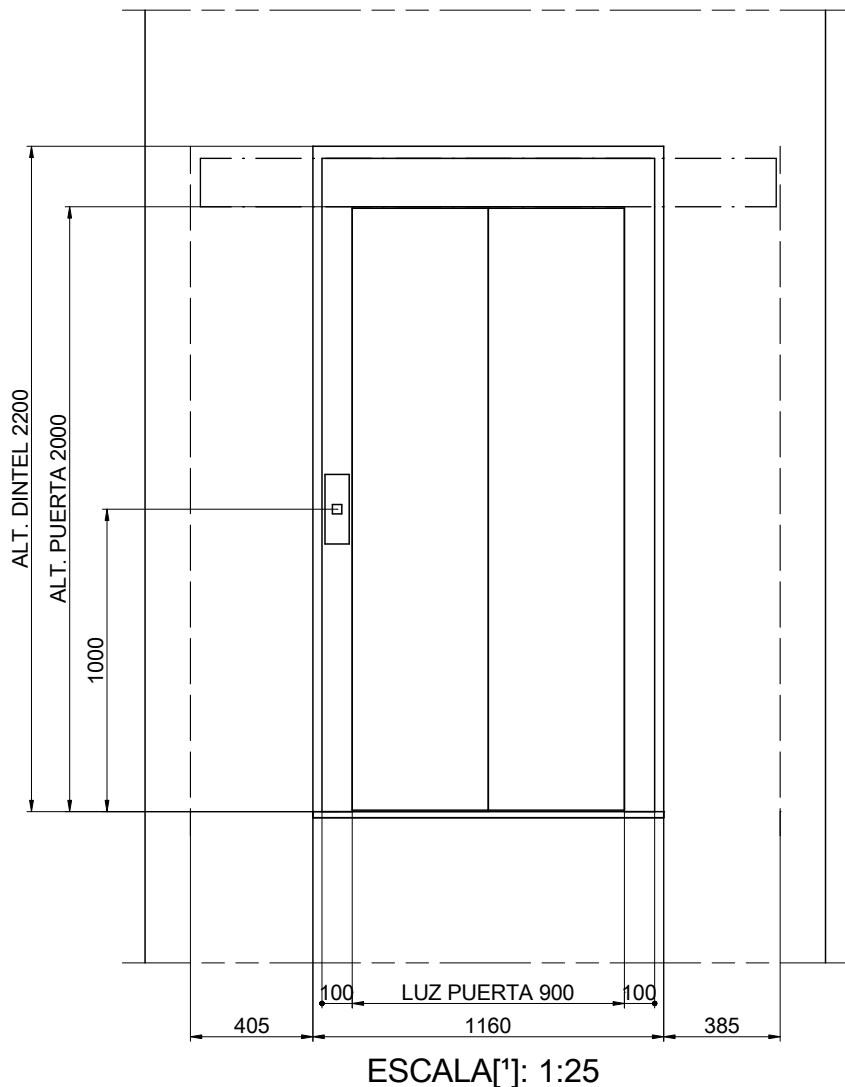

06-DETALLE DE HUECO DE PUERTA

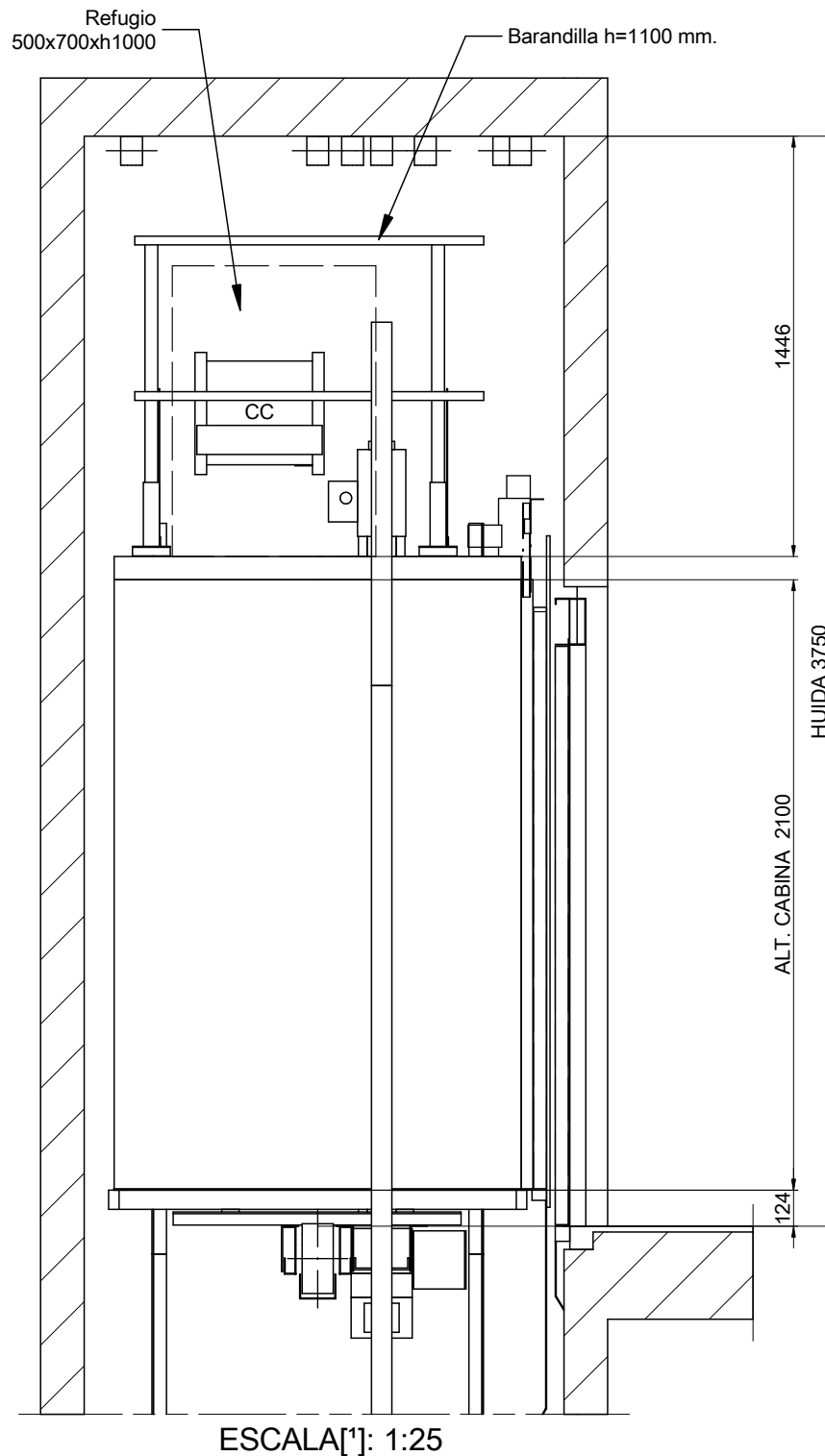

DIBUJADO	FECHA	REV.	HOJA	[*] Las dimensiones no acotadas en el plano son indicativas y no vinculantes.	
MP	2017	00	7/8		
MODELO ASCENSOR:				REFERENCIA:	CLIENTE: SITUACION OBRA:
MP GO! EVOLUTION				MPGO!EVOLUTION630SC2_ES	
CAPACIDAD: [N° PERSONAS]		8		MP ASCENSORES	
CARGA UTIL: [kg]		630			
VELOCIDAD: [m/s]		1			
FRECUENCIA: [Hz]		50			
TENSION: [V]		380V [Trifásica]			

07-HUIDA



DIBUJADO	FECHA	REV.	HOJA	[*] Las dimensiones no acotadas en el plano son indicativas y no vinculantes.	
MP	2017	00	8/8		
MODELO ASCENSOR:				REFERENCIA:	
MP GO! EVOLUTION				MPGO!EVOLUTION630SC2_ES	
CAPACIDAD: [Nº PERSONAS]				8	CLIENTE: SITUACION OBRA:
CARGA UTIL: [kg]				630	
VELOCIDAD: [m/s]				1	
FRECUENCIA: [Hz]				50	
TENSION: [V]				380V [Trifásica]	
MP ASCENSORES					