

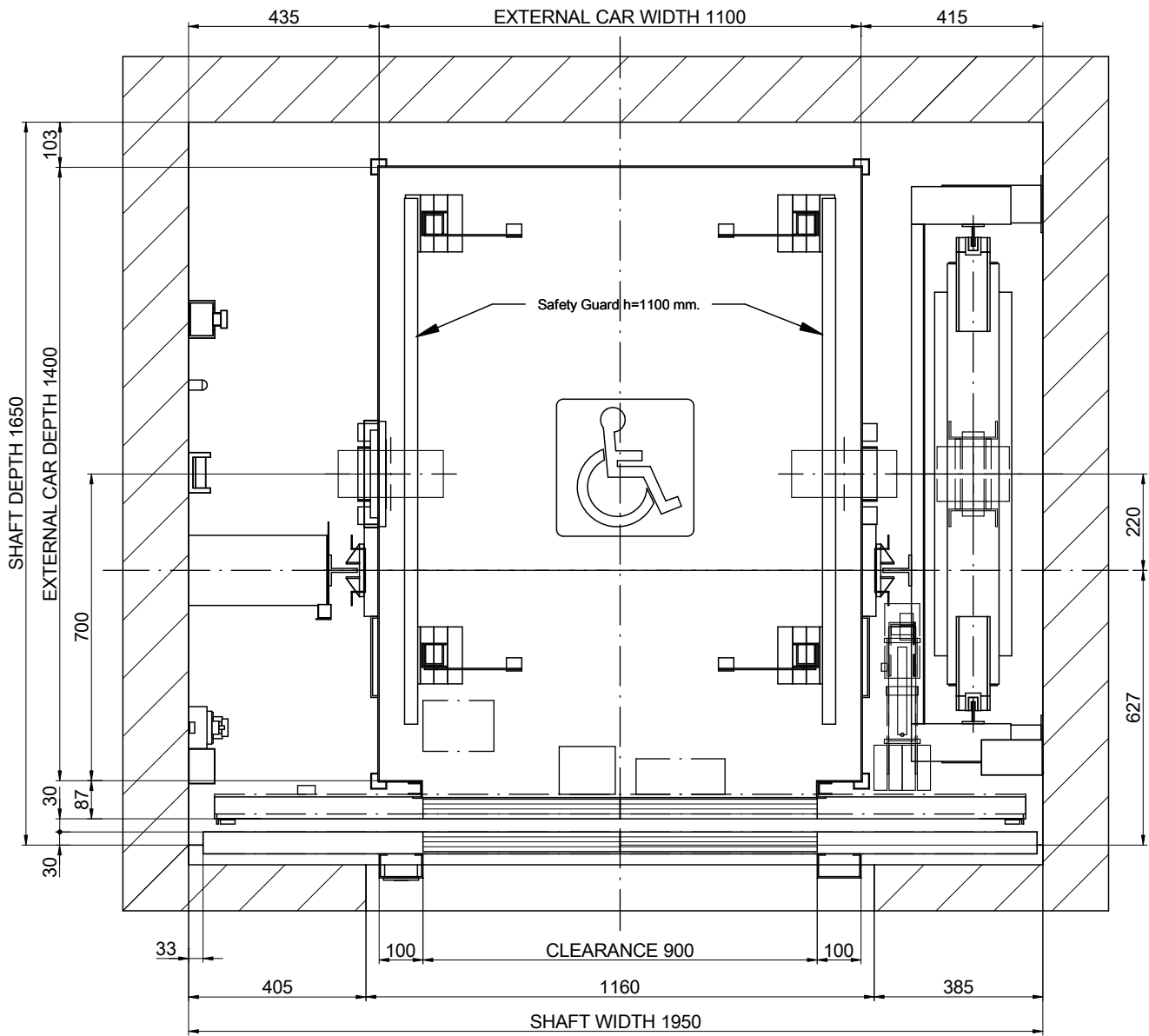

01-PLAN VIEW



SCALE[*]: 1:15

| | | | | | |
|-------------------------|------|------|-------|--|---|
| DRAWING | DATE | REV. | SHEET | [*] Unbounded dimensions in drawings are indicative and not binding. |  |
| MP | 2017 | 00 | 1/8 | | |
| MODEL LIFT: | | | | REFERENCE: | CLIENT: |
| MP GO! EVOLUTION | | | | MPGO!EVOLUTION630SC2_EN | |
| CAPACITY: [N° PERSONS] | | | | 8 | WORK SITUATION: |
| NOMINAL LOAD: [kg] | | | | 630 | |
| SPEED: [m/s] | | | | 1 | |
| FREQUENCY: [Hz] | | | | 50 | |
| TENSION: [V] | | | | 380V [Three-phase] | |
| MP LIFTS | | | | | |

01B-PLAN VIEW

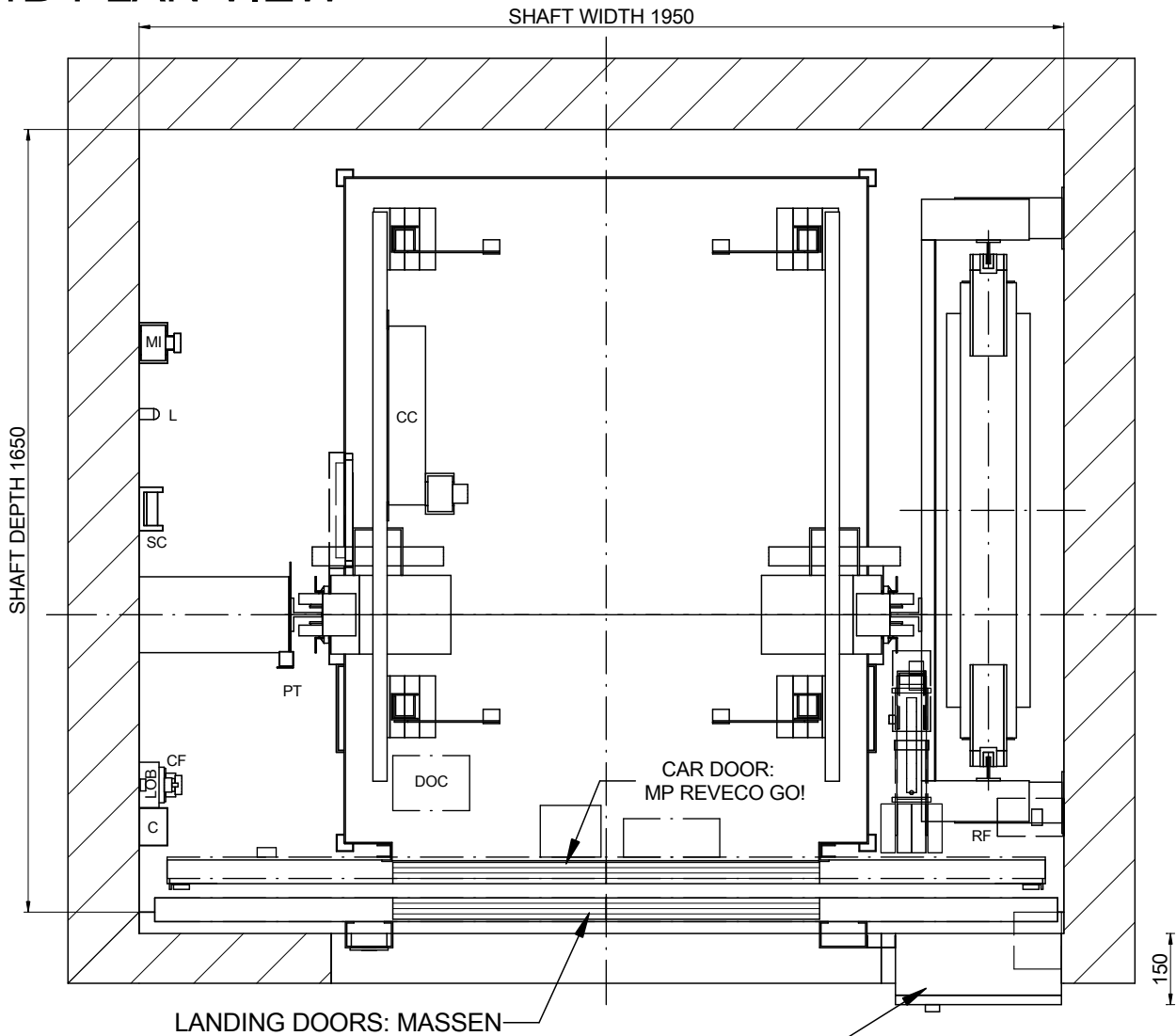

SCALE[*]: 1:15

ELECTRIC CABINET:
MP ecoGO

OPTIONAL ELECTRIC CABINET:
Via Serie (385x230x2160)

NOMENCLATURE

- C: Wiring channel
- CC: Car ceiling connection box
- CF: Pit box
- CL: Shaft light switch
- DOC: Operator control box
- L: Lamp
- LOB: Pushbutton control board
- MI: Inspection control station
- PT: Fixed cam
- RF: Brake resistor
- ST: Stopping device
- SC: Travelling cable support

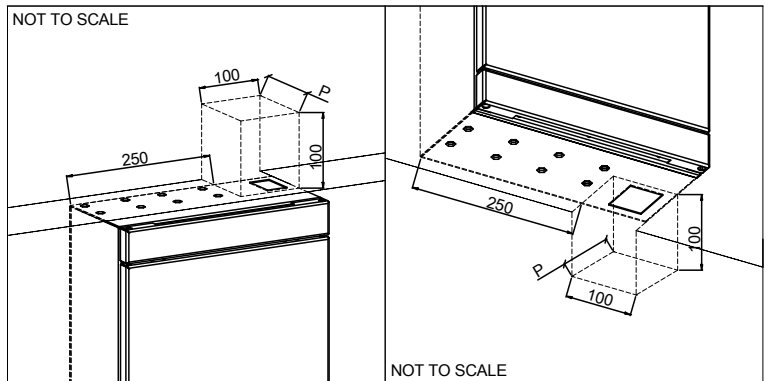

| | | | |
|-------------------------|------|--------------------|-------|
| DRAWING | DATE | REV. | SHEET |
| MP | 2017 | 00 | 2/8 |
| MODEL LIFT: | | | |
| MP GO! EVOLUTION | | | |
| CAPACITY: [N° PERSONS] | | | 8 |
| NOMINAL LOAD: [kg] | | | 630 |
| SPEED: [m/s] | | | 1 |
| FREQUENCY: [Hz] | | | 50 |
| TENSION: [V] | | 380V [Three-phase] | |

[*] Unbounded dimensions in drawings are indicative and not binding.

REFERENCE:
MPGO!EVOLUTION630SC2_EN

CLIENT:
WORK SITUATION:

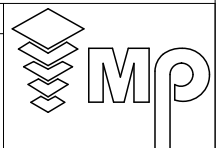

MP LIFTS

02-SIDE VERTICAL SECTION

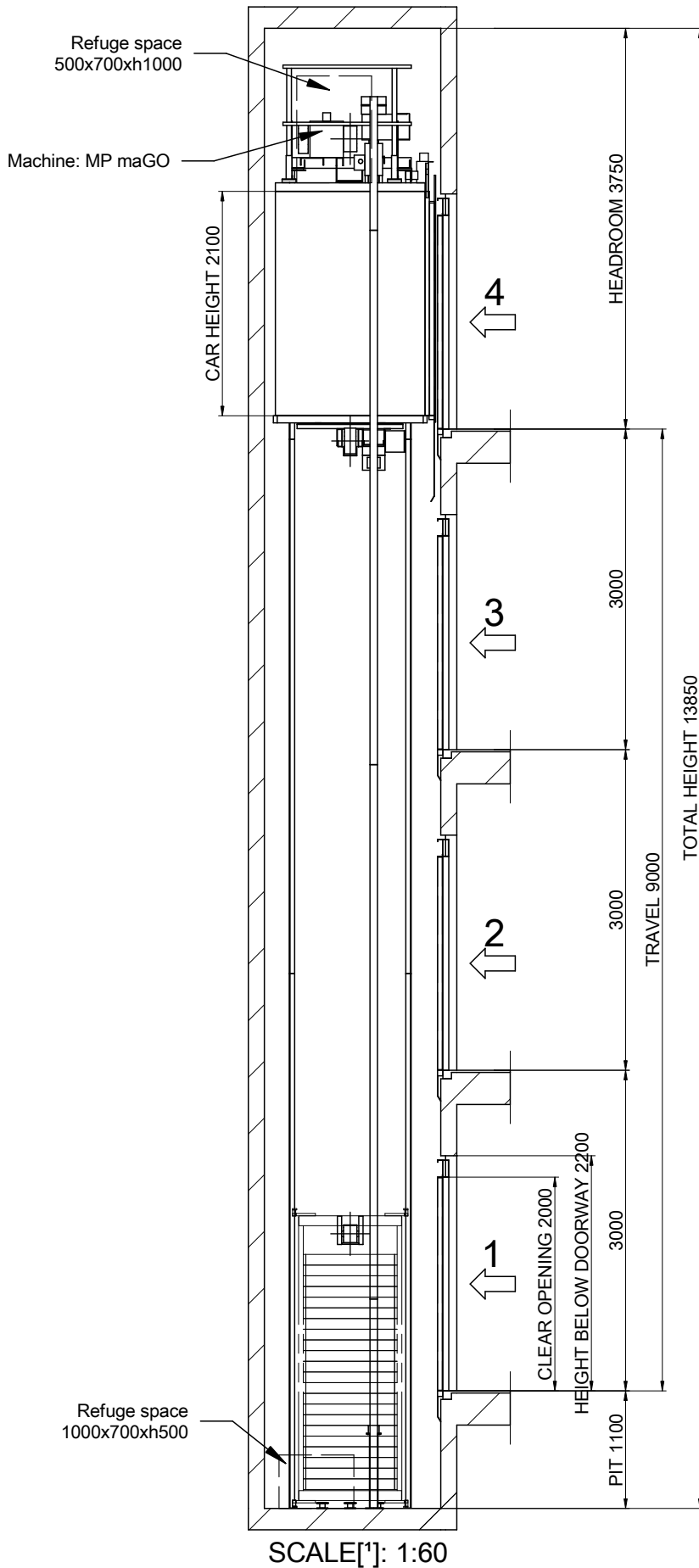

| | | | | | | |
|------------------------|--|------|----|------|-------|--|
| DRAWING | | DATE | | REV. | SHEET | [1] Unbounded dimensions in drawings are indicative and not binding. |
| | | 2017 | 00 | 3/8 | | |
| MP | | DATE | | REV. | SHEET | REFERENCE: |
| MODEL LIFT: | | 2017 | | 00 | 3/8 | MPGOIEVOLUTION630SC2_EN |
| MP GOI EVOLUTION | | DATE | | REV. | SHEET | CLIENT: |
| CAPACITY: [N° PERSONS] | | 2017 | | 00 | 3/8 | WORK SITUATION: |
| NOMINAL LOAD: [kg] | | DATE | | REV. | SHEET | |
| 630 | | 2017 | | 00 | 3/8 | |
| SPEED: [m/s] | | DATE | | REV. | SHEET | |
| 1 | | 2017 | | 00 | 3/8 | |
| FREQUENCY: [Hz] | | DATE | | REV. | SHEET | |
| 50 | | 2017 | | 00 | 3/8 | |
| TENSION: [V] | | DATE | | REV. | SHEET | |
| 380V [Three-phase] | | 2017 | | 00 | 3/8 | |

Flat and levelled floor, protected against water leaking.
 [EN81-20:2014 5.2.1.9]
 Foresee pit access device
 [EN81-20:2014 5.2.2.4]
 Stop device
 [EN81-20:2014 5.2.1.5.1. a]
 Inspection control station.
 [EN81-20:2014 5.2.1.5.1. b]
 Power supply
 [EN81-20:2014 5.2.1.5.1. c]
 Light switch
 commuted with the cabinet.
 [EN81-20:2014 5.2.1.5.1. d]



MP LIFTS

03B-FIXING DETAILS IN HEADROOM

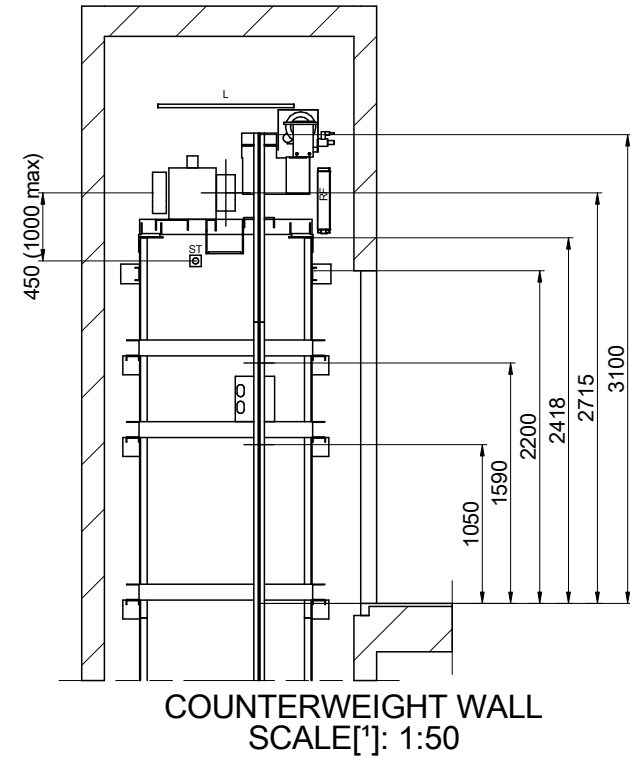
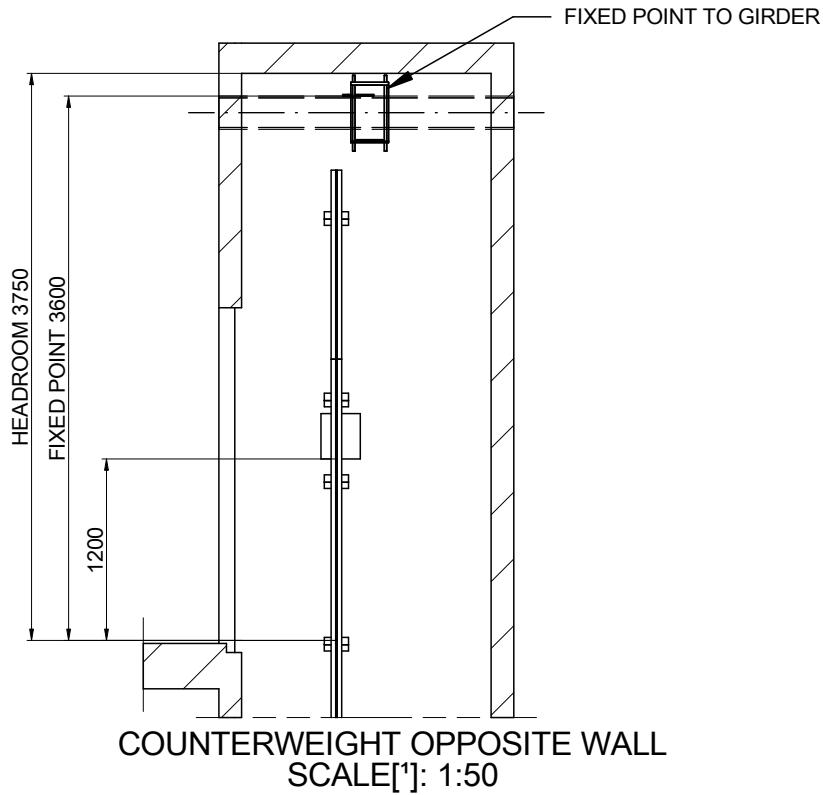

| | | | | |
|-------------------------|------|------|-------|--|
| DRAWING | DATE | REV. | SHEET | [*] Unbounded dimensions in drawings are indicative and not binding. |
| MP | 2017 | 00 | 4/8 | |
| MODEL LIFT: | | | | REFERENCE: |
| MP GO! EVOLUTION | | | | MPGO!EVOLUTION630SC2_EN |
| CAPACITY: [N° PERSONS] | | | | 8 |
| NOMINAL LOAD: [kg] | | | | 630 |
| SPEED: [m/s] | | | | 1 |
| FREQUENCY: [Hz] | | | | 50 |
| TENSION: [V] | | | | 380V [Three-phase] |
| CLIENT: | | | | MP LIFTS |
| WORK SITUATION: | | | | |



04-BEAM AND LIFTING HOOKS

POSITION OF REMOVABLE LIFTING HOOKS ABLE TO SUPPORT
1000 kg EACH ONE SUPPLIED BY CONSTRUCTOR
(RECOMMENDED POSITION LOADHOOKS)

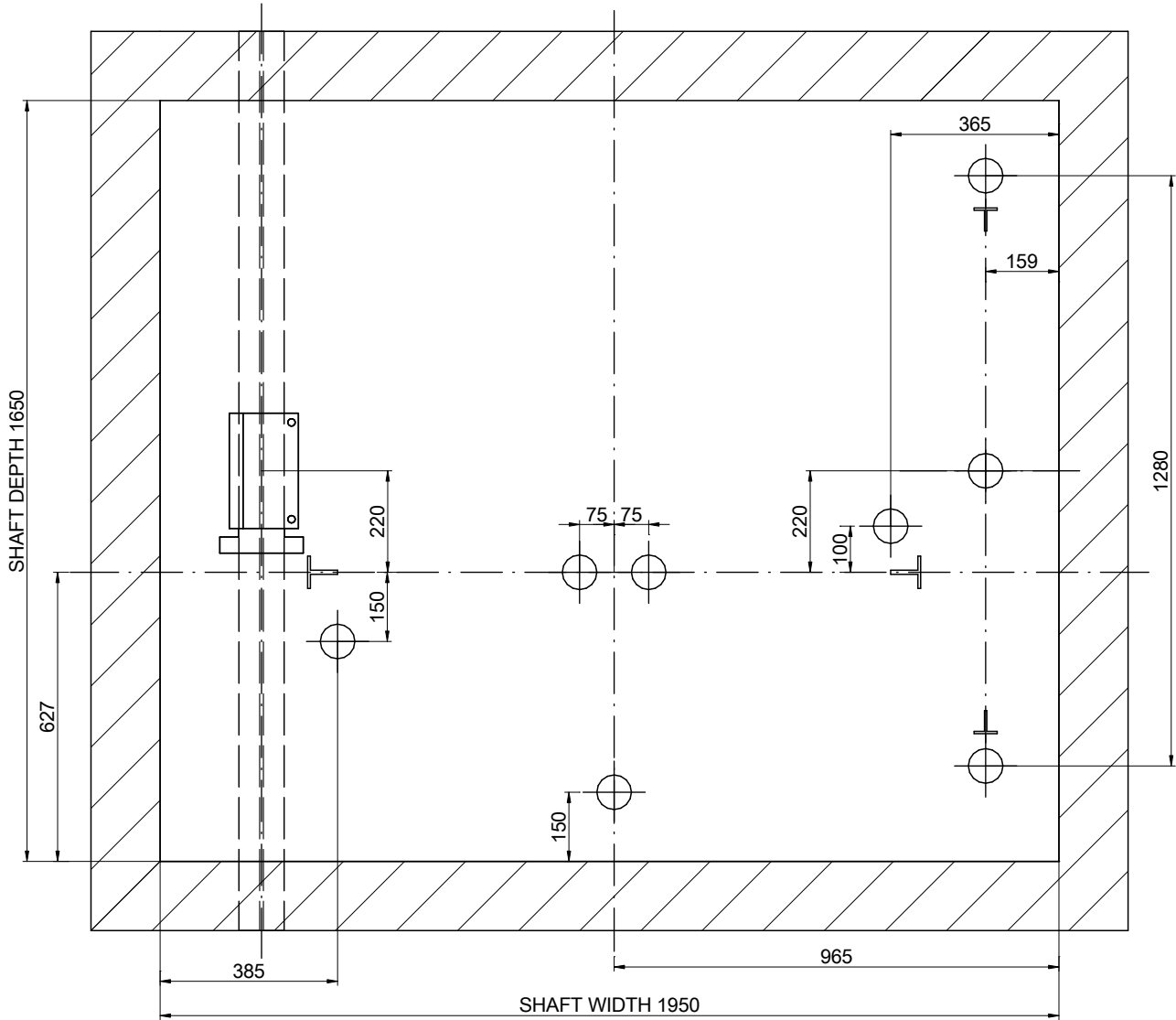

SCALE[*]: 1:15

| | | | | | |
|-------------------------|------|--------------------|-------|--|---|
| DRAWING | DATE | REV. | SHEET | [*] Unbounded dimensions in drawings are indicative and not binding. |  |
| MP | 2017 | 00 | 5/8 | REFERENCE: MPGO!EVOLUTION630SC2_EN | |
| MODEL LIFT: | | | | CLIENT: | MP LIFTS |
| MP GO! EVOLUTION | | | | WORK SITUATION: | |
| CAPACITY: [N° PERSONS] | | | 8 | | |
| NOMINAL LOAD: [kg] | | | 630 | | |
| SPEED: [m/s] | | | 1 | | |
| FREQUENCY: [Hz] | | | 50 | | |
| TENSION: [V] | | 380V [Three-phase] | | | |

05-PIT LAYOUT

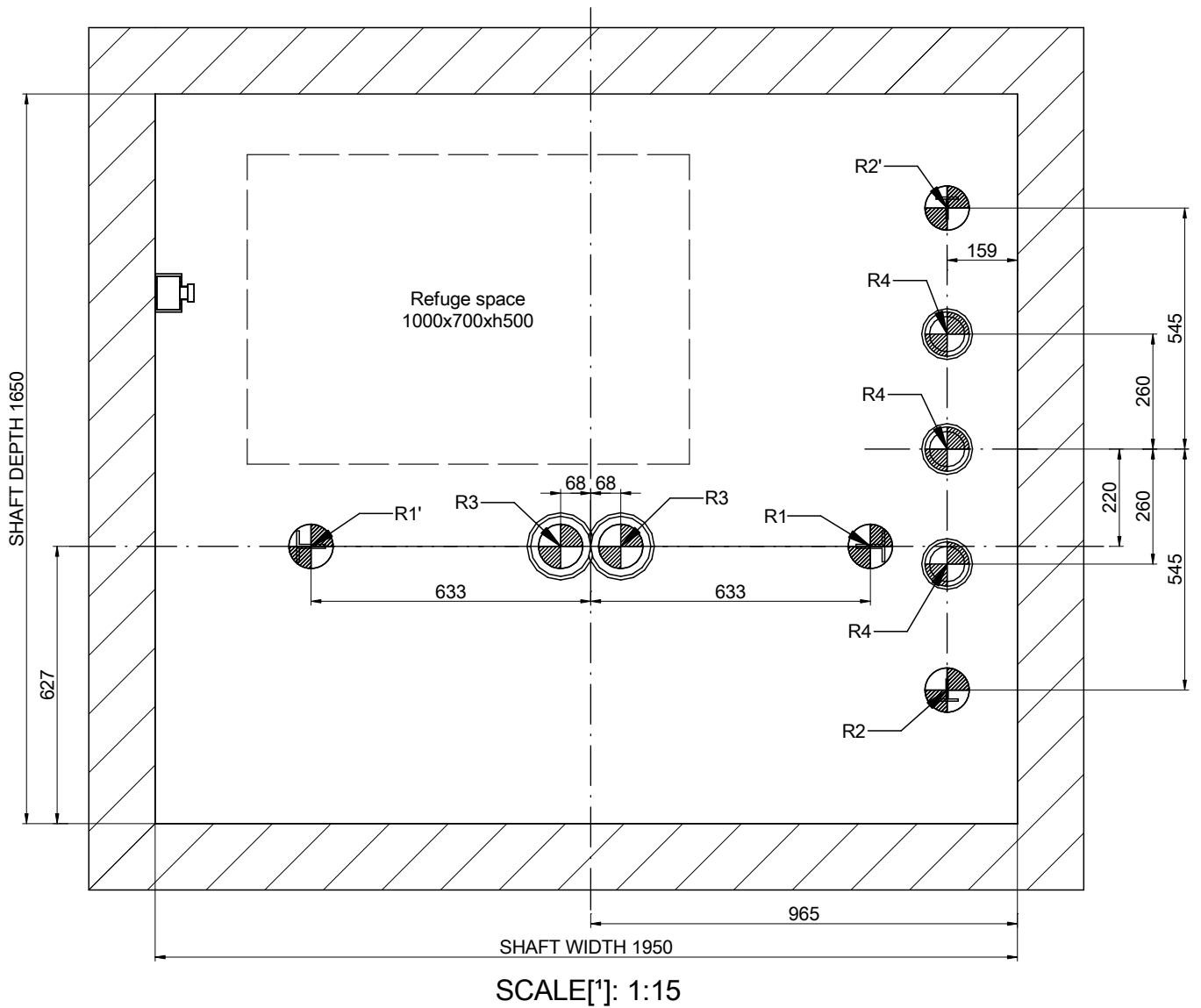

| REACTIONS [N] [max.] | | | |
|----------------------|-------|-----|-------|
| R1 | 30000 | R2 | 22000 |
| R1' | 26000 | R2' | 23000 |
| R3 | 31500 | R4 | 17000 |
| N | 2000 | T | 1100 |

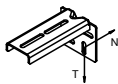

| DRAWING | DATE | REV. | SHEET | [*] Unbounded dimensions in drawings are indicative and not binding. |
|------------------------|------|------|--------------------|--|
| MP | 2017 | 00 | 6/8 | REFERENCE: MPGO!EVOLUTION630SC2_EN |
| MODEL LIFT: | | | | MP LIFTS |
| MP GO! EVOLUTION | | | | |
| CAPACITY: [N° PERSONS] | | | 8 | CLIENT: WORK SITUATION: |
| NOMINAL LOAD: [kg] | | | 630 | |
| SPEED: [m/s] | | | 1 | |
| FREQUENCY: [Hz] | | | 50 | |
| TENSION: [V] | | | 380V [Three-phase] | |

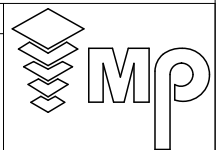

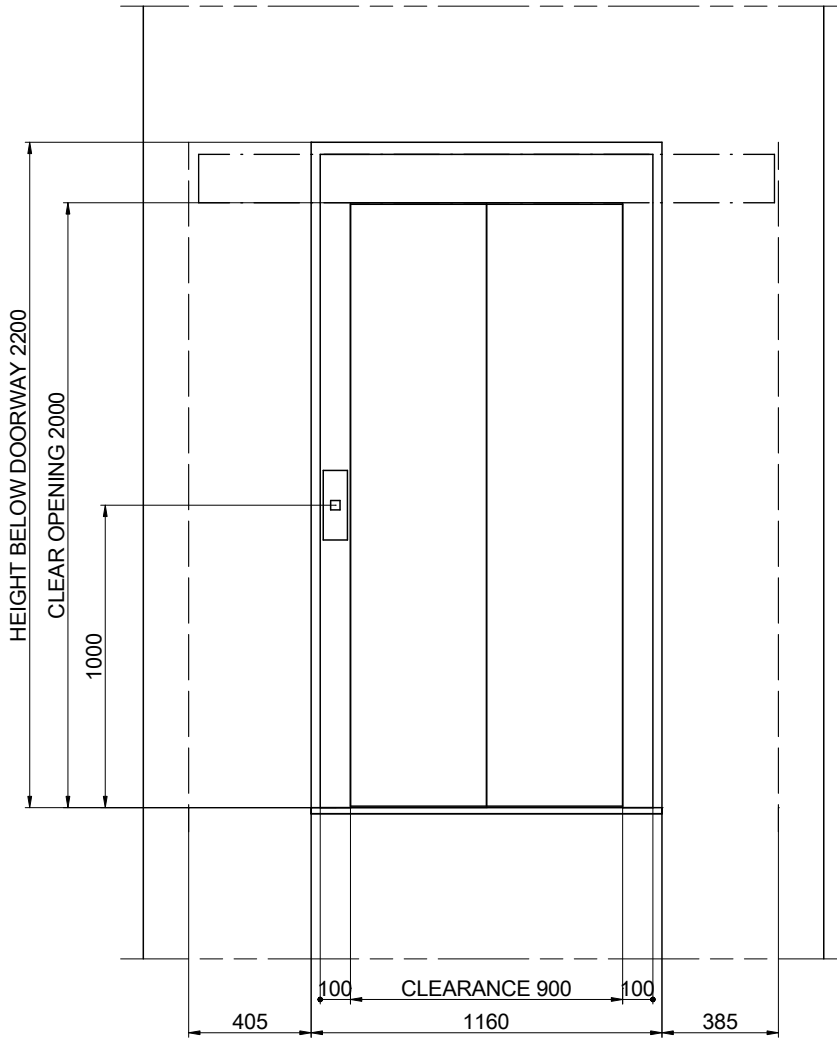

06-DOOR HOLE DETAIL

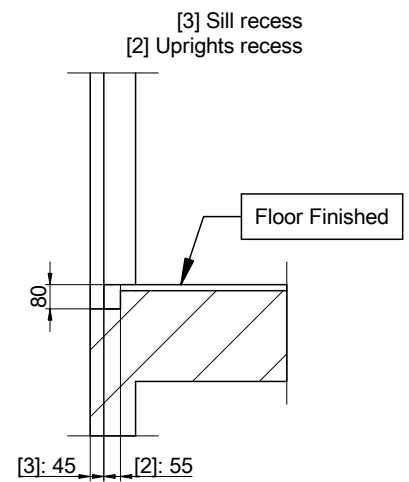

SCALE[1]: 1:25



SCALE[1]: 1:25

| | | | | | |
|------------------------|------|------|-------|--|---|
| DRAWING | DATE | REV. | SHEET | [*] Unbounded dimensions in drawings are indicative and not binding. |  |
| MP | 2017 | 00 | 7/8 | | |
| MODEL LIFT: | | | | REFERENCE: |  |
| MP GO! EVOLUTION | | | | MPGO!EVOLUTION630SC2_EN | |
| CAPACITY: [N° PERSONS] | | | | CLIENT: | <p style="text-align: center; font-size: 2em; font-weight: bold;">MP LIFTS</p> |
| NOMINAL LOAD: [kg] | | | | WORK SITUATION: | |
| SPEED: [m/s] | | | | | |
| FREQUENCY: [Hz] | | | | | |
| TENSION: [V] | | | | | |

07-HEADROOM

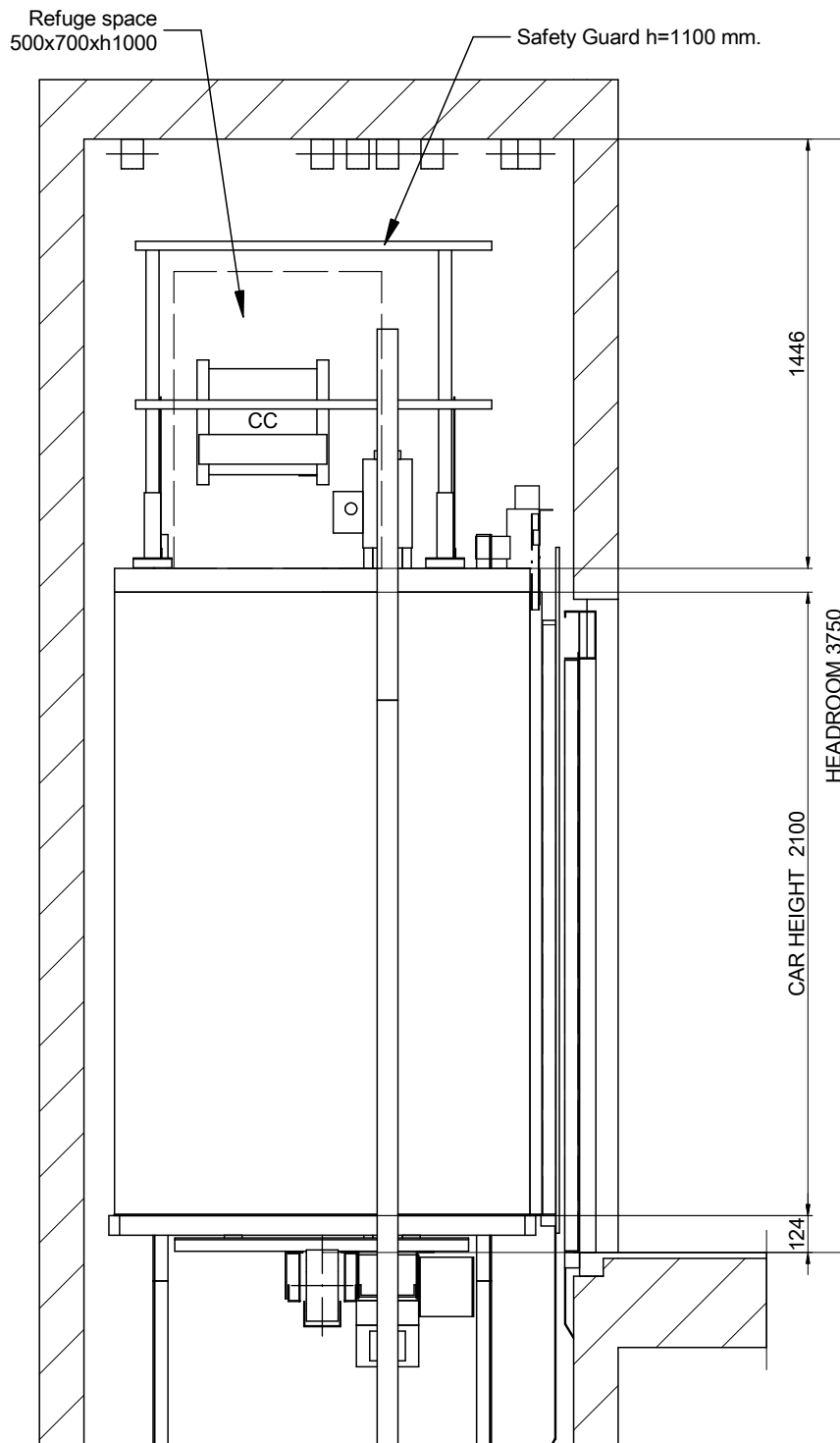

SCALE[*]: 1:25

| | | | | | |
|------------------------|------|------|--------------------|---|---|
| DRAWING | DATE | REV. | SHEET | [*] Unbounded dimensions in drawings are indicative and not binding. REFERENCE: MPGO!EVOLUTION630SC2_EN |  |
| MP | 2017 | 00 | 8/8 | | |
| MODEL LIFT: | | | | CLIENT: | WORK SITUATION: |
| MP GO! EVOLUTION | | | | | |
| CAPACITY: [N° PERSONS] | | | 8 | MP LIFTS | |
| NOMINAL LOAD: [kg] | | | 630 | | |
| SPEED: [m/s] | | | 1 | | |
| FREQUENCY: [Hz] | | | 50 | | |
| TENSION: [V] | | | 380V [Three-phase] | | |