

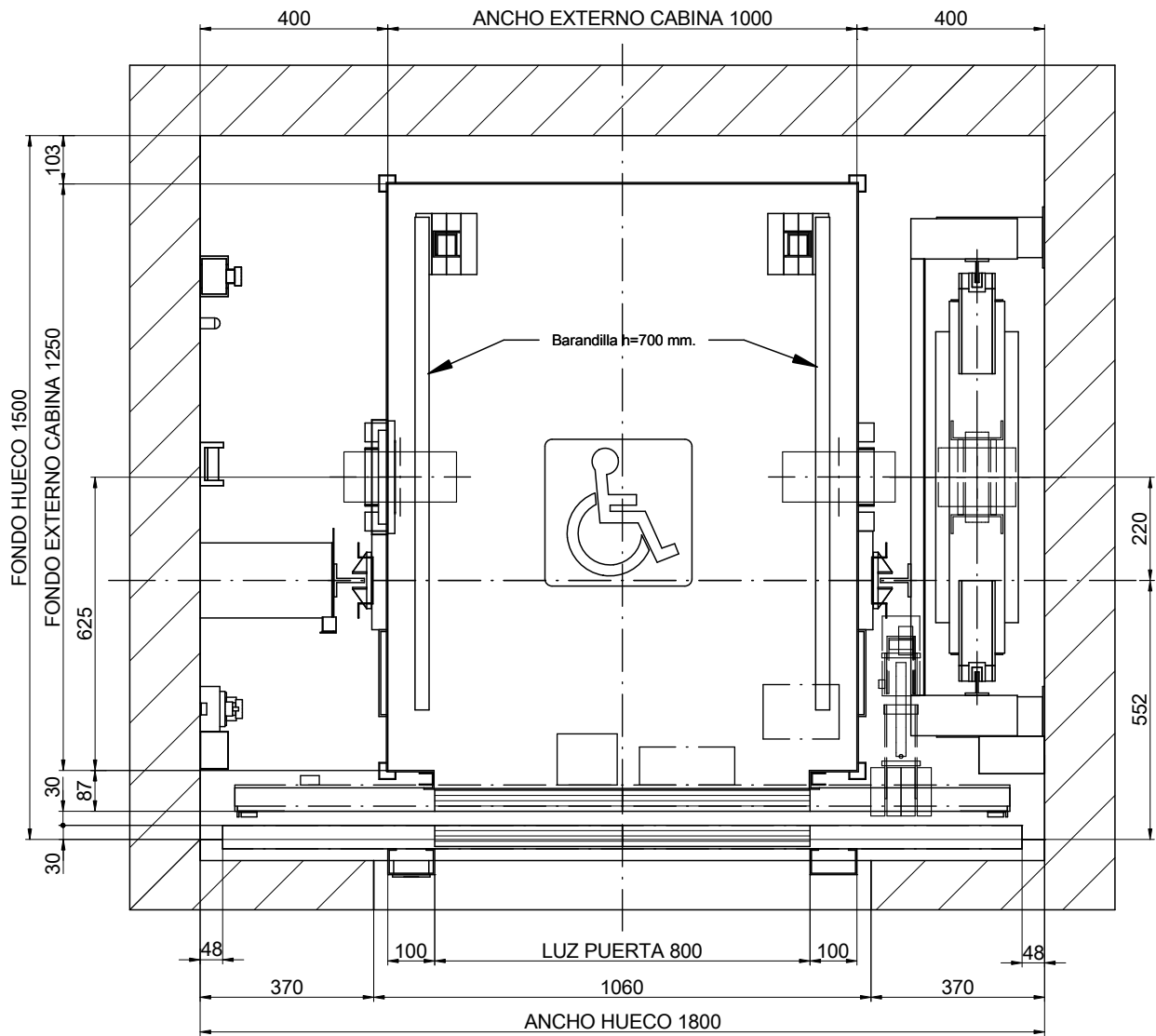

# 01-PLANTA



ESCALA[\*]: 1:15

DIBUJADO	FECHA	REV.	HOJA	[*] Las dimensiones no acotadas en el plano son indicativas y no vinculantes.	
MP	2017	00	1/8		
MODELO ASCENSOR:				REFERENCIA:	
<b>MP GO! EVOLUTION</b>				MPGO!EVOLUTION480SC2_ES	
CAPACIDAD: [N° PERSONAS]				6	CLIENTE:
CARGA UTIL: [kg]				480	SITUACION OBRA:
VELOCIDAD: [m/s]				1	
FRECUENCIA: [Hz]				50	
TENSION: [V]				380V [Trifásica]	<b>MP ASCENSORES</b>

# 01B-PLANTA

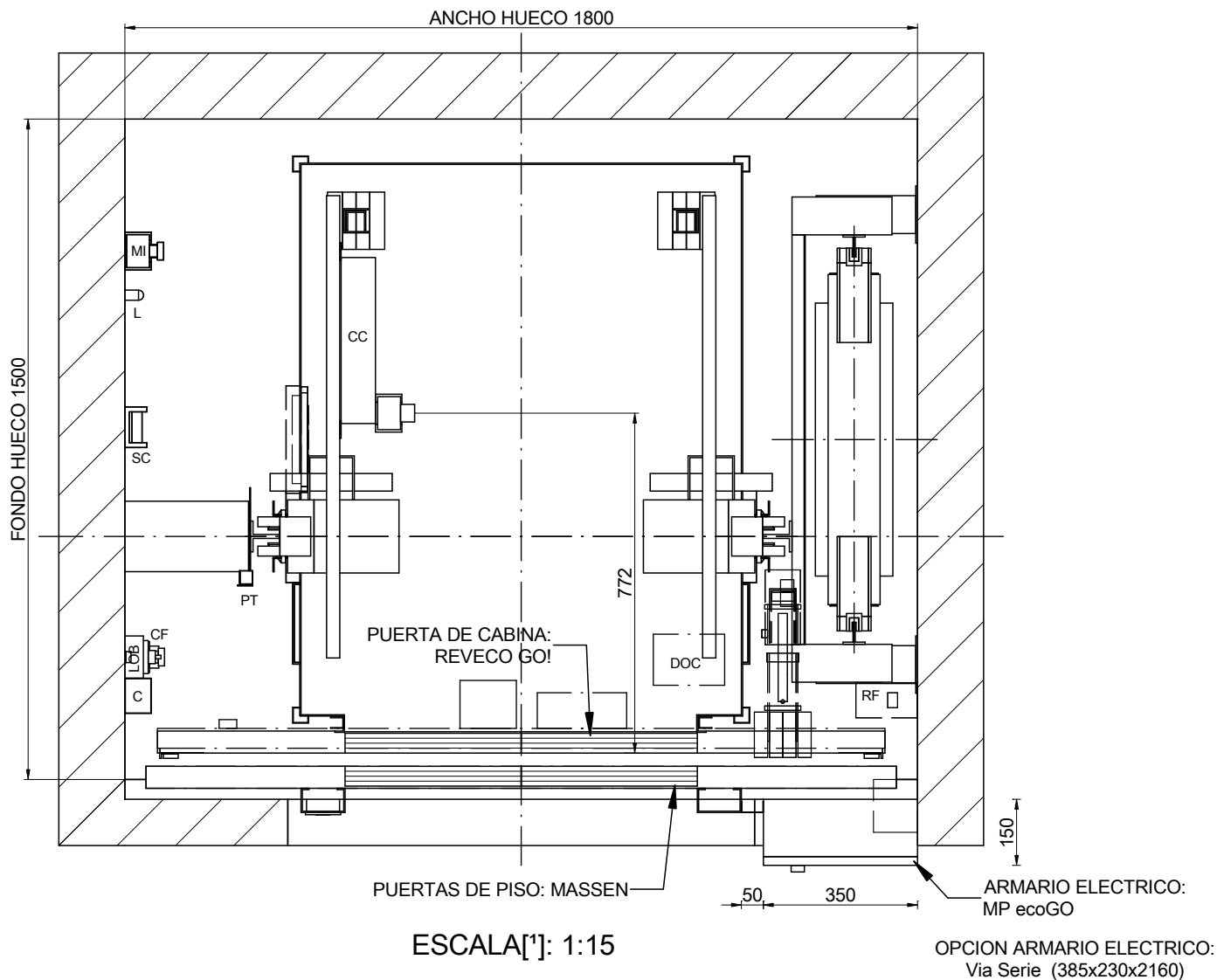

## NOMENCLATURA

- C: Canaleta
- CC: Caja conexiones techo cabina
- CF: Caja foso
- CL: Conmutador Luz Hueco
- DOC: Caja Control Operador
- L: Luminaria
- LOB: Placa Control Botoneras
- MI: Mando Inspección
- PT: Patín
- RF: Resistencia Frenado
- ST: Dispositivo parada
- SC: Soporte cuerda maniobra

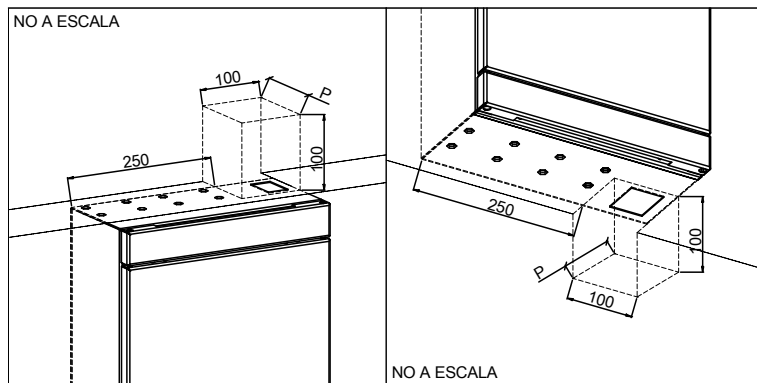

DIBUJADO	FECHA	REV.	HOJA
MP	2017	00	2/8
MODELO ASCENSOR:			
<b>MP GO! EVOLUTION</b>			
CAPACIDAD: [Nº PERSONAS]		6	
CARGA UTIL: [kg]		480	
VELOCIDAD: [m/s]		1	
FRECUENCIA: [Hz]		50	
TENSION: [V]		380V [Trifásica]	

[\*] Las dimensiones no acotadas en el plano son indicativas y no vinculantes.

REFERENCIA:  
MPGO!EVOLUTION480SC2\_ES

CLIENTE:  
SITUACION OBRA:

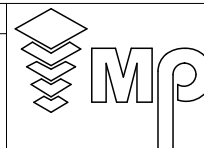

**MP ASCENSORES**

# 02-ALZADO LATERAL

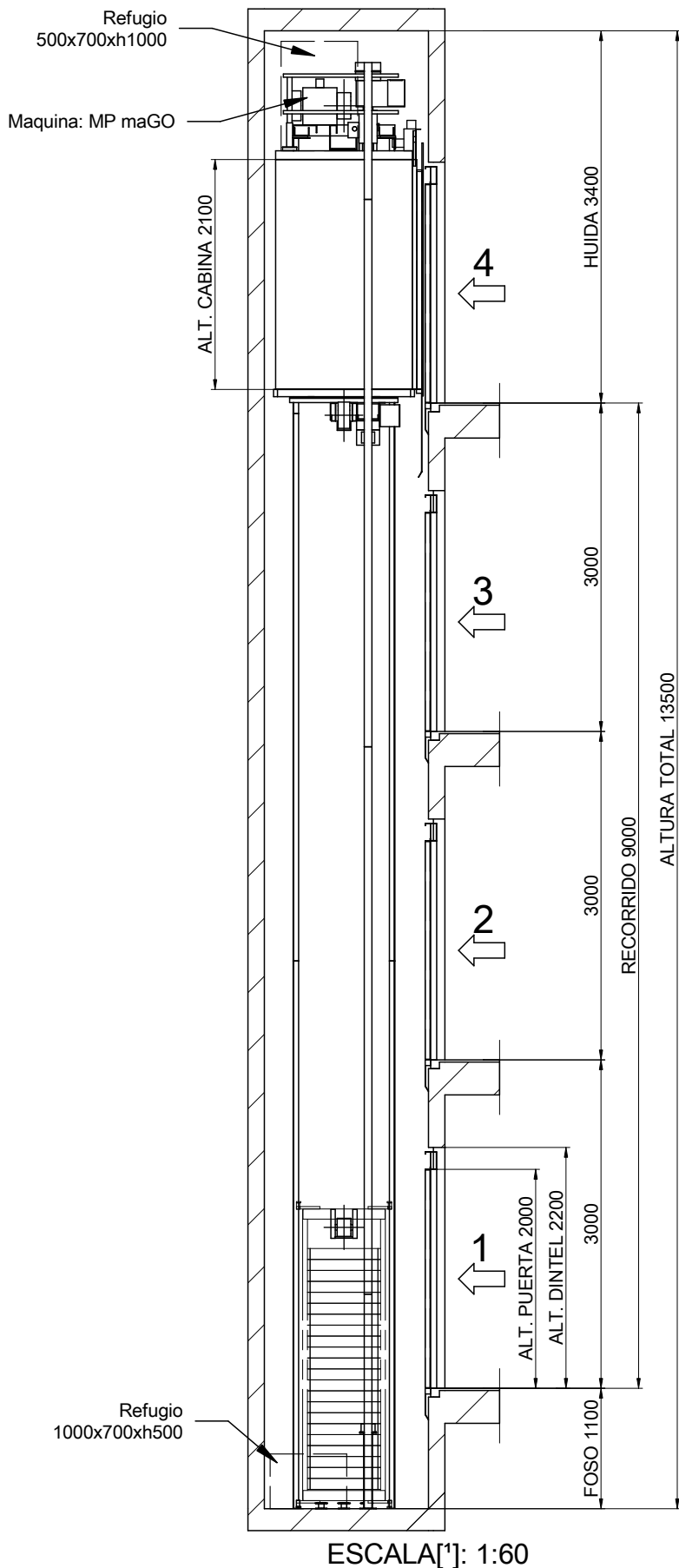

			[*] Las dimensiones no acotadas en el plano son indicativas y no vinculantes.		
DIBUJADO	FECHA	REV.	HOJA	REFERENCIA:	
MP	2017	00	3/8	MPGOIEVOLUTION480SC2_ES	
MODELO ASCENSOR:					
MP GOI EVOLUTION					
CAPACIDAD: [N° PERSONAS]		6			
CARGA UTIL: [kg]		480			
VELOCIDAD: [m/s]		1			
FRECUENCIA: [Hz]		50			
TENSION: [V]		380V [Trifásica]			
CLIENTE:					
SITUACION OBRA:					
<b>MP ASCENSORES</b>					

Foso liso y a nivel protegido de infiltraciones de agua. [EN81-20:2014 5.2.1.9]  
 Prever dispositivo de acceso. [EN81-20:2014 5.2.2.4]  
 Dispositivo de parada. [EN81-20:2014 5.2.1.5.1. a]  
 Estación de control de inspección. [EN81-20:2014 5.2.1.5.1 b]  
 Toma de corriente. [EN81-20:2014 5.2.1.5.1. c]  
 Interruptor de alumbrado, conmutado con el armario. [EN81-20:2014 5.2.1.5.1. d]

# 03B-DETALLES DE FIJACION EN LA HUIDA

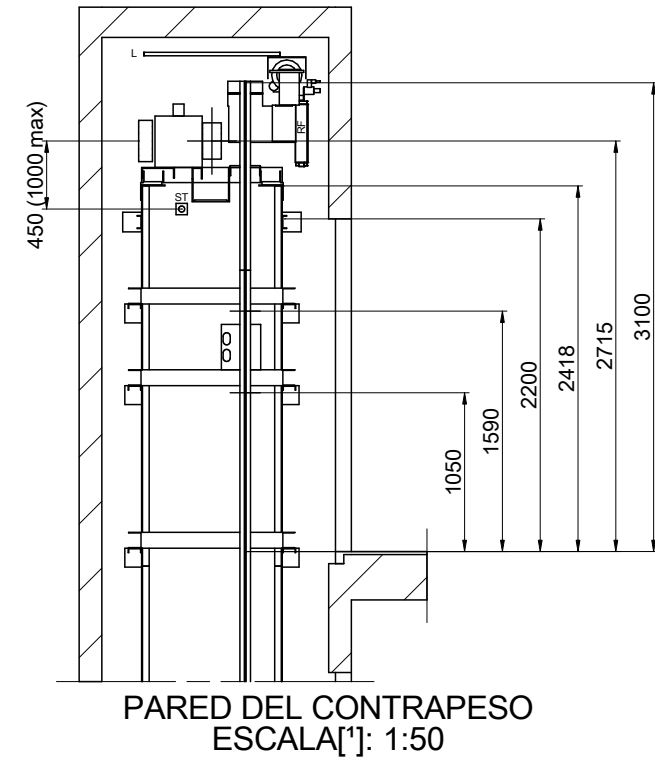
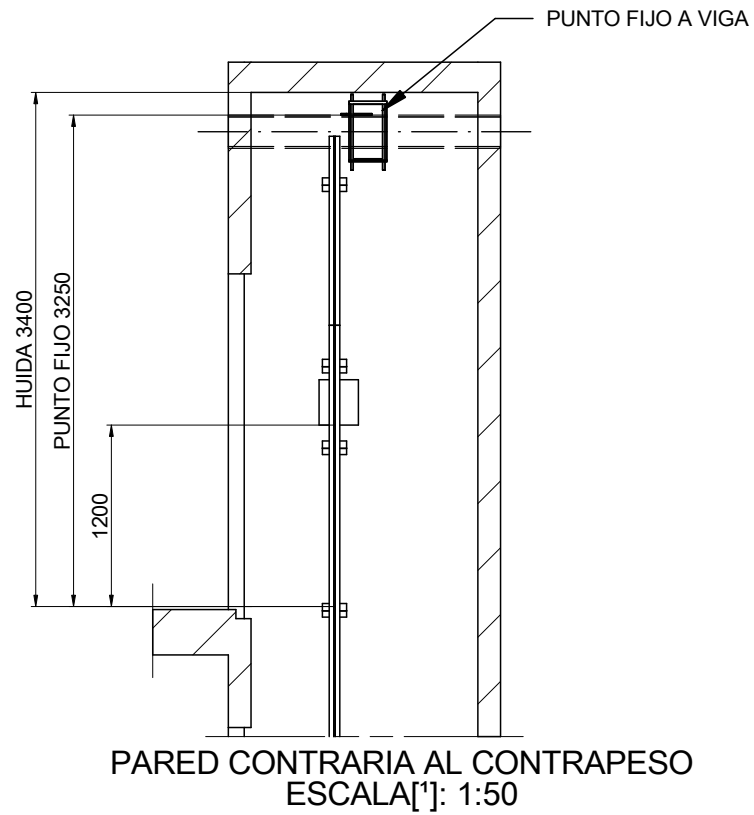

DIBUJADO	FECHA	REV.	HOJA
MP	2017	00	4/8
MODELO ASCENSOR:			
<b>MP GO! EVOLUTION</b>			
CAPACIDAD: [N° PERSONAS]			6
CARGA UTIL: [kg]			480
VELOCIDAD: [m/s]			1
FRECUENCIA: [Hz]			50
TENSION: [V]		380V [Trifásica]	

[\*] Las dimensiones no acotadas en el plano son indicativas y no vinculantes.

REFERENCIA:  
MPGO!EVOLUTION480SC2\_ES

CLIENTE:  
SITUACION OBRA:

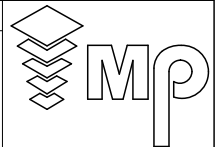



**MP ASCENSORES**

# 04-VIGA Y GANCHOS DE MONTAJE

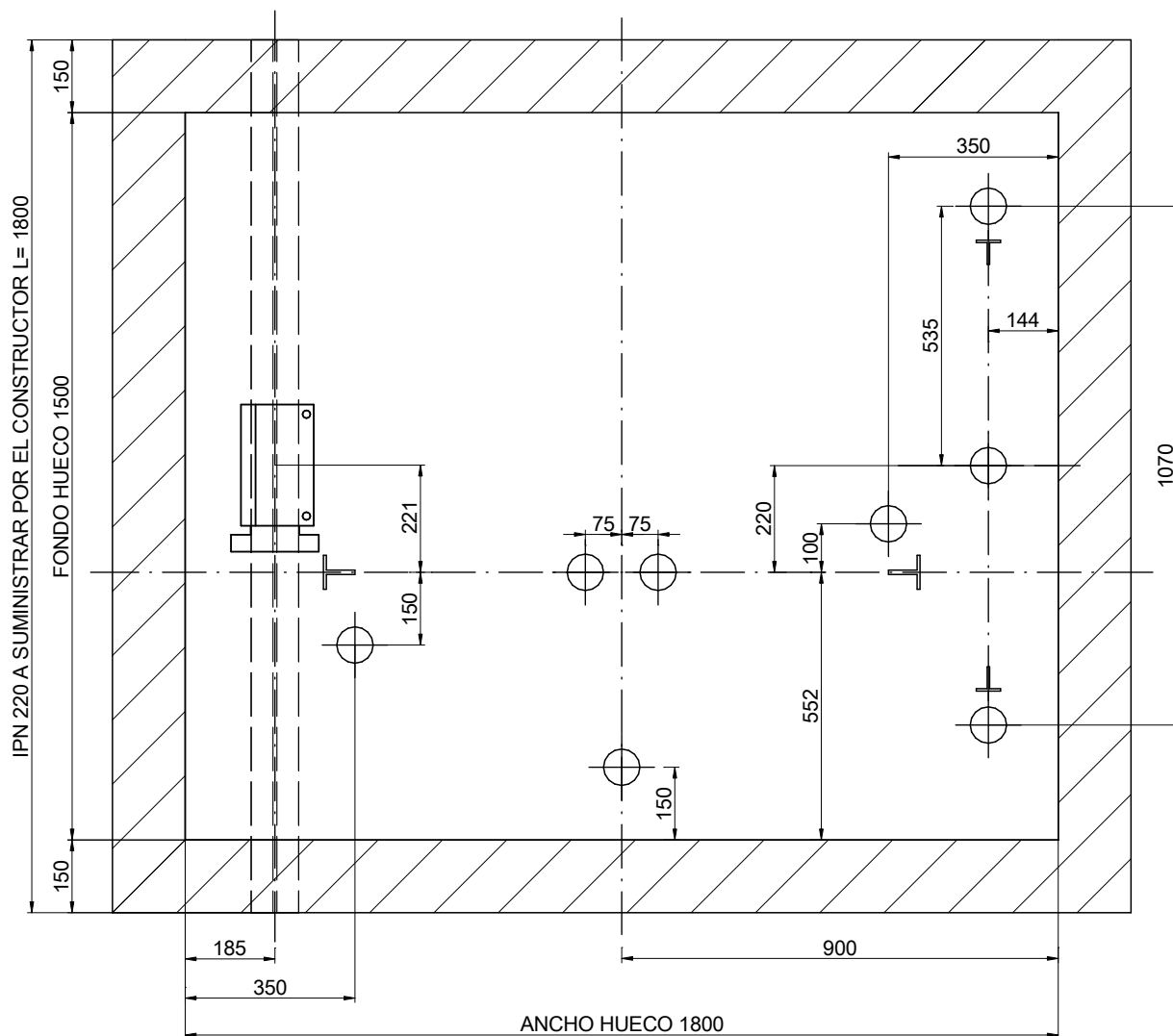
POSICION DE LOS GANCHOS DESMONTABLES CAPACES DE SOPORTAR  
1000 kg CADA UNO A SUMINISTRAR POR EL CONSTRUCTOR  
(POSICION RECOMENDADA GANCHOS DE MONTAJE)



ESCALA[\*]: 1:15

DIBUJADO	FECHA	REV.	HOJA	[*] Las dimensiones no acotadas en el plano son indicativas y no vinculantes.	
MP	2017	00	5/8		
MODELO ASCENSOR:				REFERENCIA:	
MP GO! EVOLUTION				MPGO!EVOLUTION480SC2_ES	
CAPACIDAD: [N° PERSONAS]				6	CLIENTE: SITUACION OBRA:
CARGA UTIL: [kg]				480	
VELOCIDAD: [m/s]				1	
FRECUENCIA: [Hz]				50	
TENSION: [V]				380V [Trifásica]	
<b>MP ASCENSORES</b>					

# 05-PLANTA DE FOSO

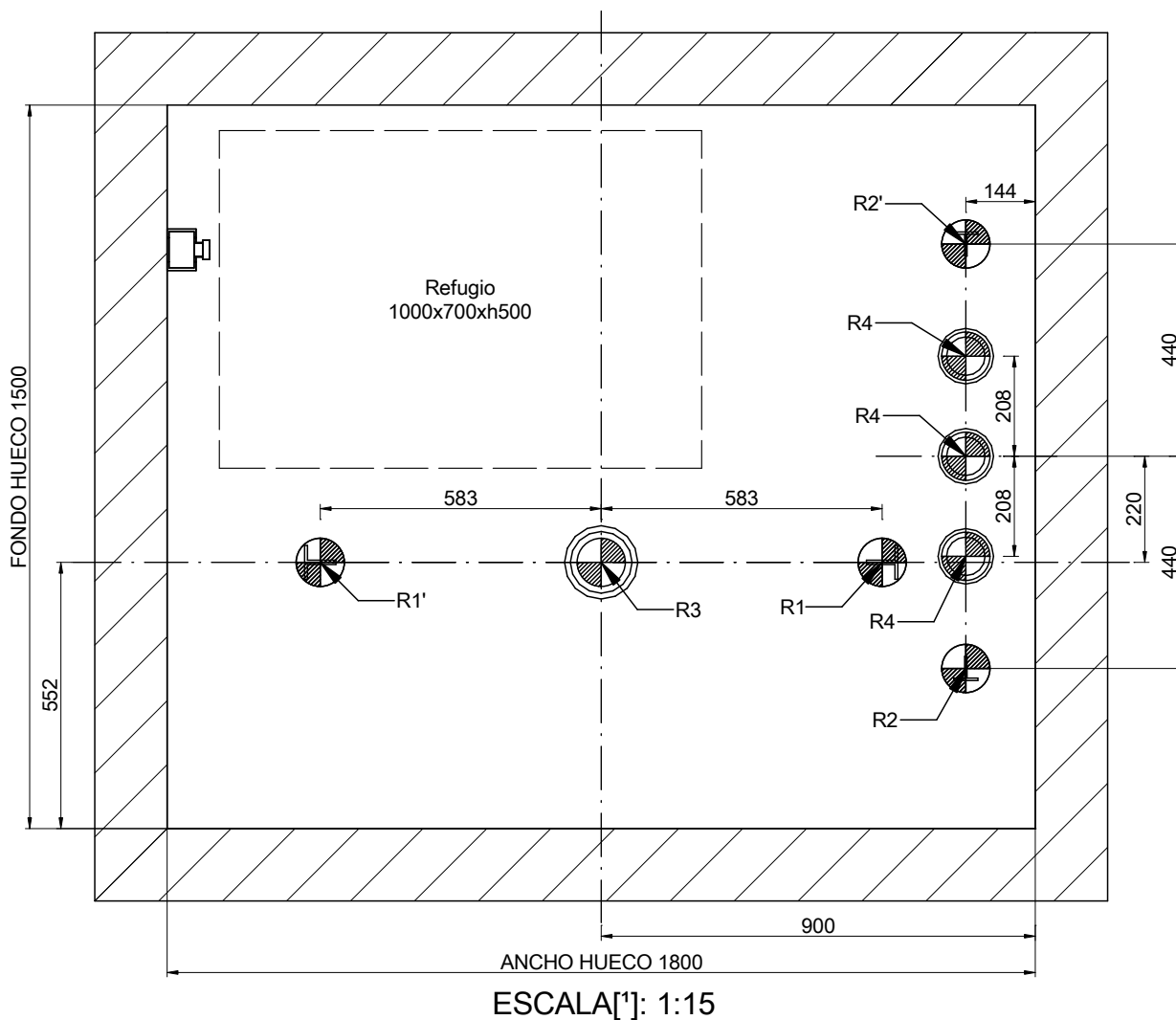

REACCIONES [N] [max.]					
R1	28000	R2	20500		
R1'	25000	R2'	21000		
R3	57000	R4	16000		
N	1800	T	850		

DIBUJADO	FECHA	REV.	HOJA	[*] Las dimensiones no acotadas en el plano son indicativas y no vinculantes.		
MP	2017	00	6/8	REFERENCIA: MPGO!EVOLUTION480SC2_ES		
MODELO ASCENSOR:				CLIENTE:		
MP GO! EVOLUTION				SITUACION OBRA:		<h2>MP ASCENSORES</h2>
CAPACIDAD: [Nº PERSONAS]			6			
CARGA UTIL: [kg]			480			
VELOCIDAD: [m/s]			1			
FRECUENCIA: [Hz]			50			
TENSION: [V]		380V [Trifásica]				

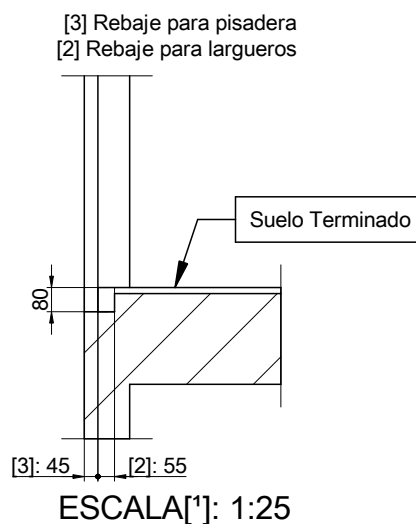
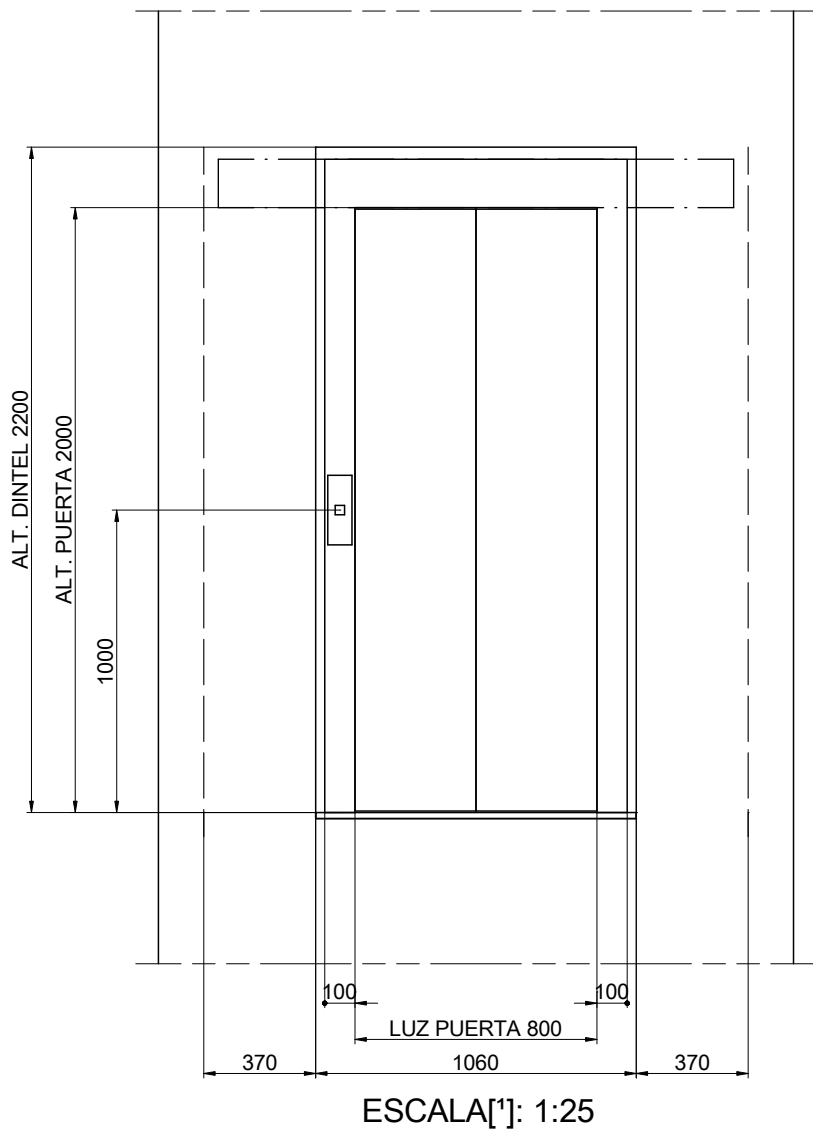

# 06-DETALLE DE HUECO DE PUERTA

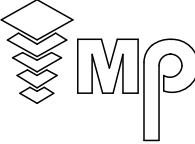

DIBUJADO	FECHA	REV.	HOJA	[*] Las dimensiones no acotadas en el plano son indicativas y no vinculantes.	
MP	2017	00	7/8	REFERENCIA: MPGO!EVOLUTION480SC2_ES	
MODELO ASCENSOR:				CLIENTE:	SITUACION OBRA:
MP GO! EVOLUTION					
CAPACIDAD: [N° PERSONAS]			6	<p style="text-align: center;"><b>MP ASCENSORES</b></p>	
CARGA UTIL: [kg]			480		
VELOCIDAD: [m/s]			1		
FRECUENCIA: [Hz]			50		
TENSION: [V]			380V [Trifásica]		

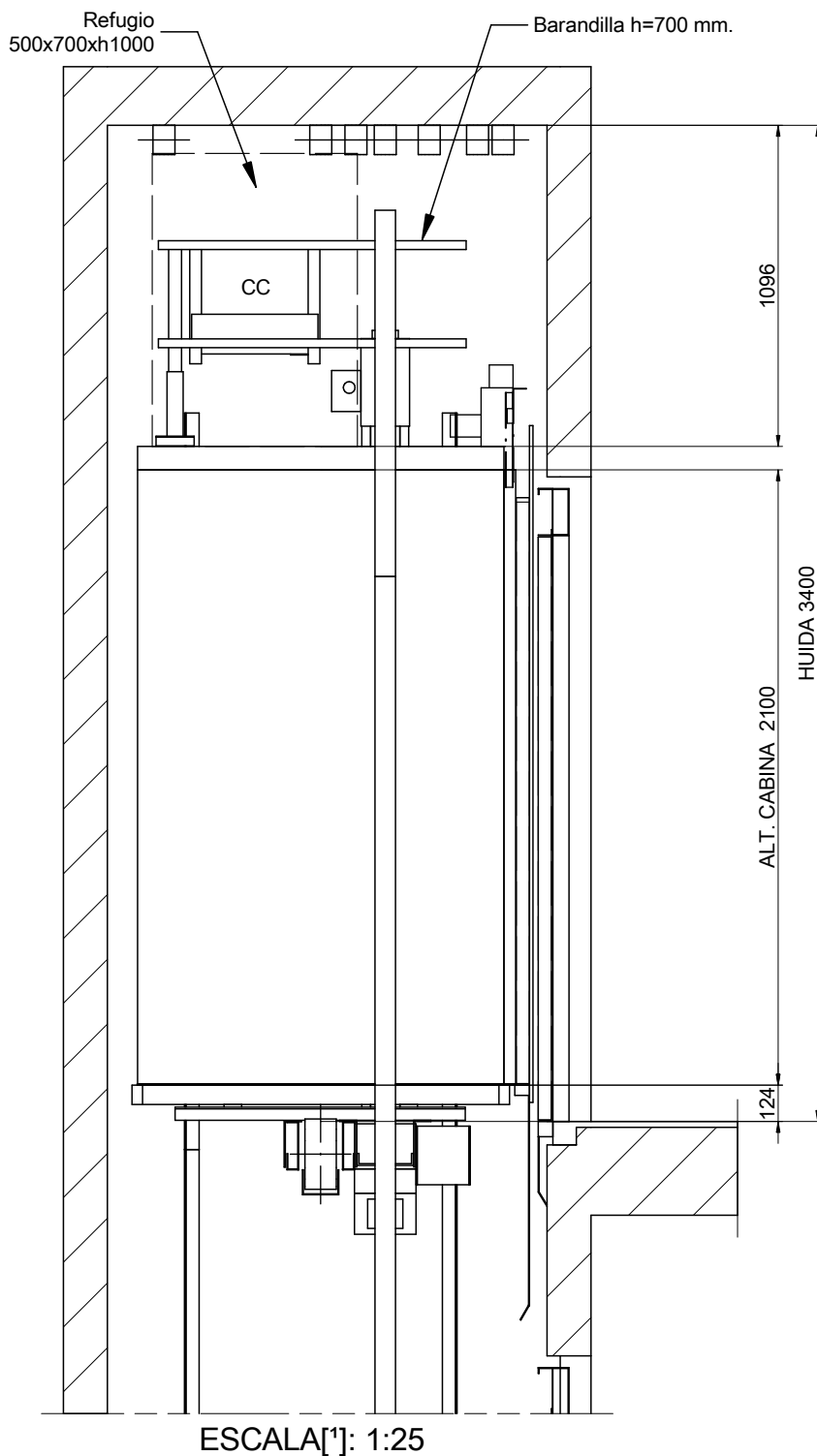
# 07-HUIDA



DIBUJADO	FECHA	REV.	HOJA	[*] Las dimensiones no acotadas en el plano son indicativas y no vinculantes.	
MP	2017	00	8/8		
MODELO ASCENSOR:				REFERENCIA:	
MP GO! EVOLUTION				MPGO!EVOLUTION480SC2_ES	
CAPACIDAD: [Nº PERSONAS]				6	CLIENTE: SITUACION OBRA:
CARGA UTIL: [kg]				480	
VELOCIDAD: [m/s]				1	
FRECUENCIA: [Hz]				50	
TENSION: [V]				380V [Trifásica]	
<b>MP ASCENSORES</b>					