

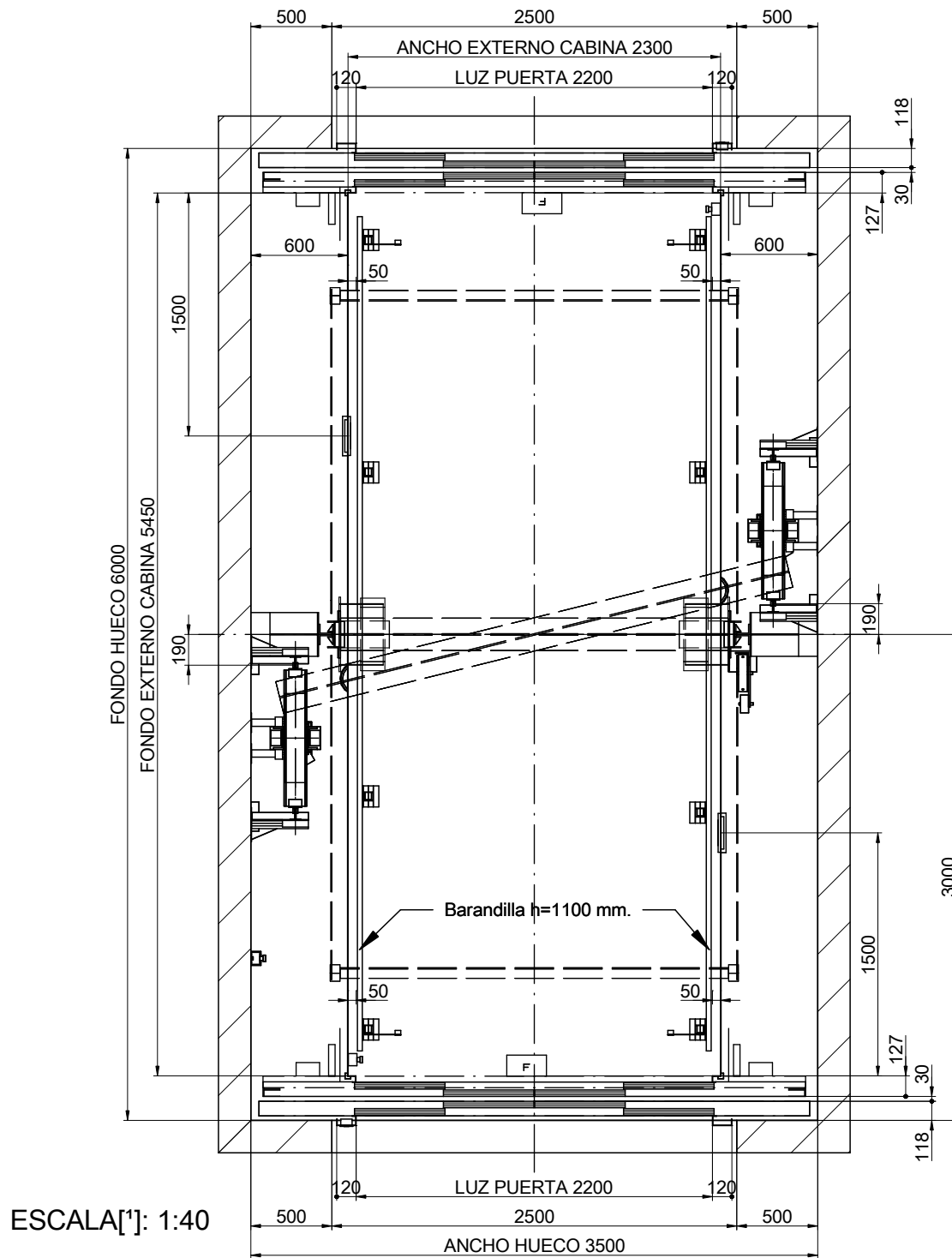

01-PLANTA



DIBUJADO	FECHA	REV.	HOJA	[*] Las dimensiones no acotadas en el plano son indicativas y no vinculantes.	
MP	2017	00	1/9		
MODELO ASCENSOR:				REFERENCIA:	
MP H				MPH_MONTACOCHEs_3500_ES	
CAPACIDAD: [Nº PERSONAS]				CLIENTE:	
46				SITUACION OBRA:	
CARGA UTIL: [kg]					
3500					
VELOCIDAD: [m/s]					
0.2					
FRECUENCIA: [Hz]					
50					
TENSION: [V]					
380V [Trifásica]					
MP ASCENSORES					

01B-PLANTA

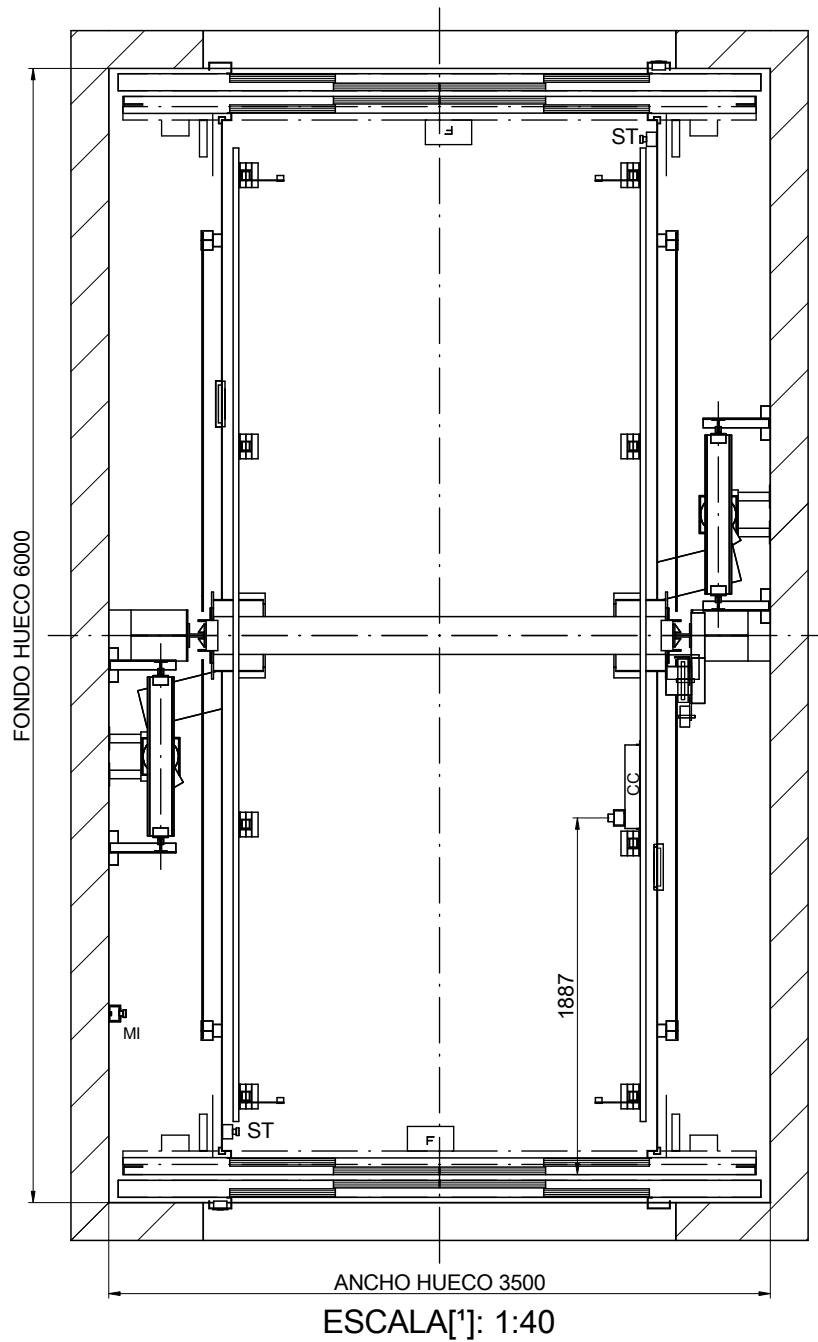

NOMENCLATURA

CC: Caja conexiones techo cabina

ST: Dispositivo parada

MI: Mando Inspección

DIBUJADO	FECHA	REV.	HOJA	[*] Las dimensiones no acotadas en el plano son indicativas y no vinculantes.	
MP	2017	00	2/9	REFERENCIA: MPH_MONTACOCHEES_3500_ES	
MODELO ASCENSOR:				CLIENTE:	MP ASCENSORES
MP H				SITUACION OBRA:	
CAPACIDAD: [Nº PERSONAS]			46		
CARGA UTIL: [kg]			3500		
VELOCIDAD: [m/s]			0.2		
FRECUENCIA: [Hz]			50		
TENSION: [V]		380V [Trifásica]			

02-ALZADO LATERAL

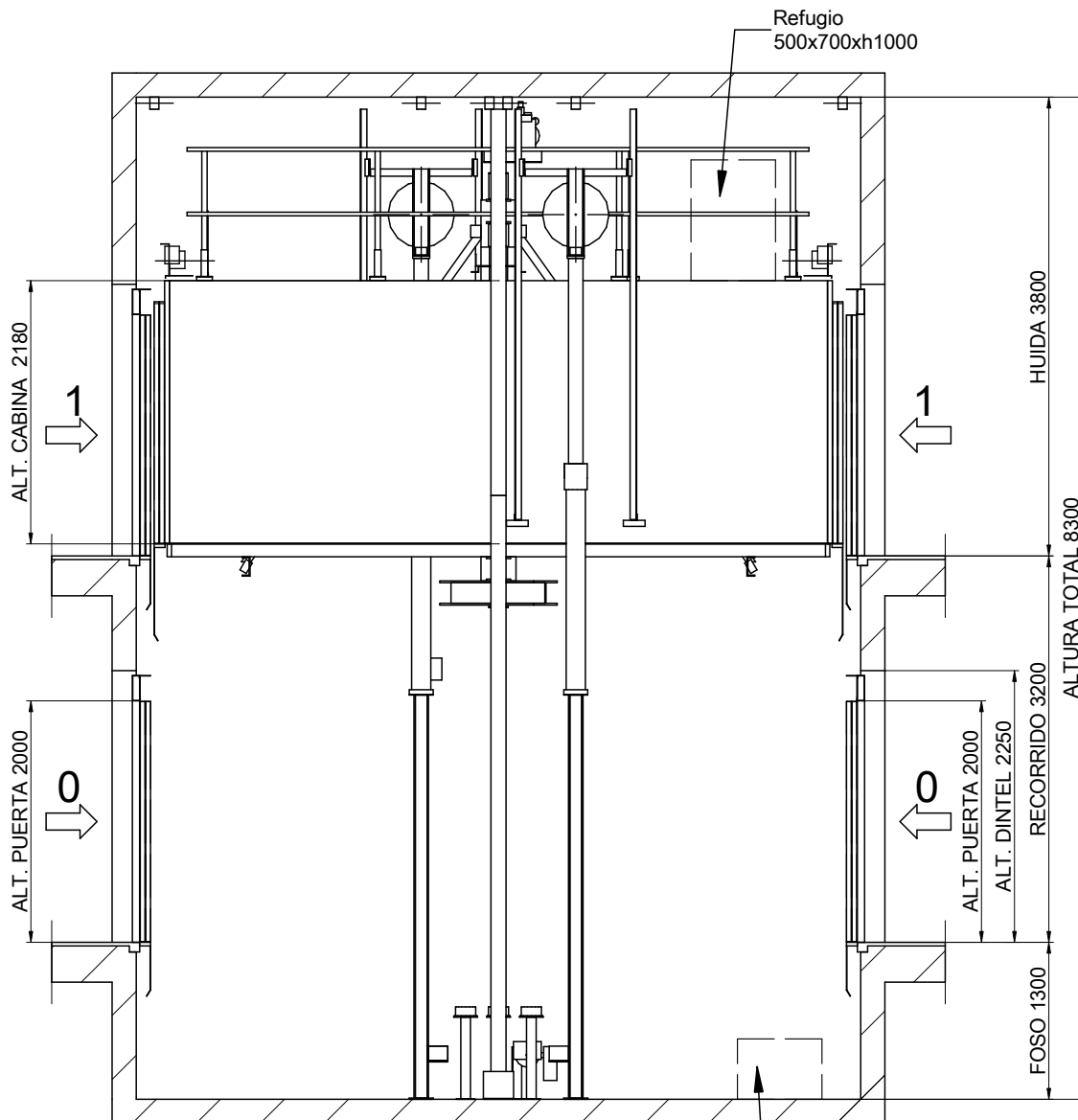

ESCALA[*]: 1:60

Foso liso y a nivel protegido de infiltraciones de agua.
 [EN81-20:2014 5.2.1.9]
 Prever dispositivo de acceso.
 [EN81-20:2014 5.2.2.4]
 Dispositivo de parada.
 [EN81-20:2014 5.2.1.5.1. a]
 Estación de control de inspección.
 [EN81-20:2014 5.2.1.5.1 b]
 Toma de corriente.
 [EN81-20:2014 5.2.1.5.1. c]
 Interruptor de alumbrado, conmutado con el armario.
 [EN81-20:2014 5.2.1.5.1. d]

Refugio 1000x700xh500

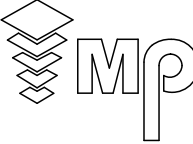
DIBUJADO	FECHA	REV.	HOJA	[*] Las dimensiones no acotadas en el plano son indicativas y no vinculantes.	
MP	2017	00	3/9	REFERENCIA: MPH_MONTACOCHEES_3500_ES	
MODELO ASCENSOR:				CLIENTE:	MP ASCENSORES
MP H				SITUACION OBRA:	
CAPACIDAD: [Nº PERSONAS]			46		
CARGA UTIL: [kg]			3500		
VELOCIDAD: [m/s]			0.2		
FRECUENCIA: [Hz]			50		
TENSION: [V]			380V [Trifásica]		

04-VIGA Y GANCHOS DE MONTAJE

POSICION DE LOS GANCHOS DESMONTABLES CAPACES DE SOPORTAR
3500 kg CADA UNO A SUMINISTRAR POR EL CONSTRUCTOR
(POSICION RECOMENDADA GANCHOS DE MONTAJE)

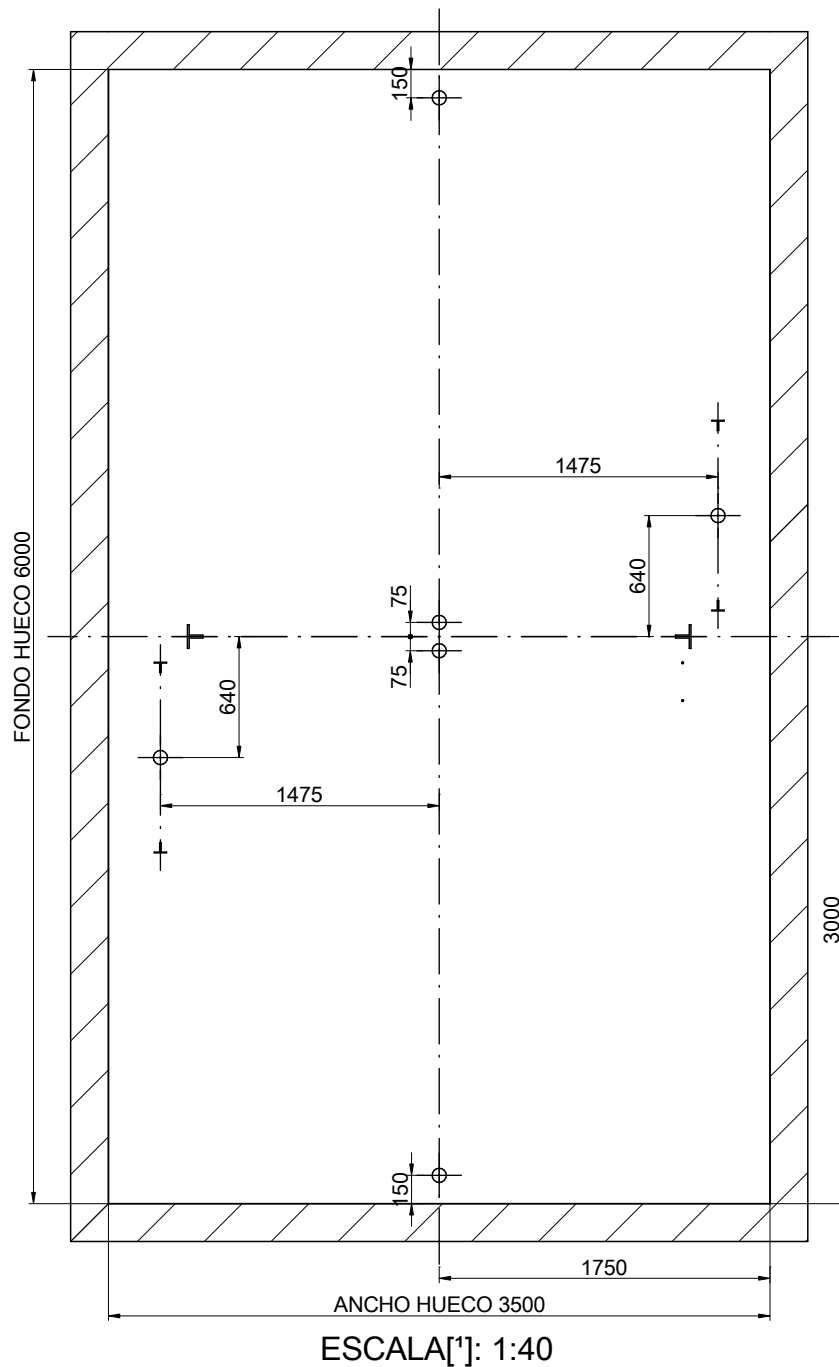

DIBUJADO	FECHA	REV.	HOJA	[*] Las dimensiones no acotadas en el plano son indicativas y no vinculantes.	
MP	2017	00	4/9	REFERENCIA: MPH_MONTACOCHEES_3500_ES	
MODELO ASCENSOR:				CLIENTE:	MP ASCENSORES
MP H				SITUACION OBRA:	
CAPACIDAD: [N° PERSONAS]			46		
CARGA UTIL: [kg]			3500		
VELOCIDAD: [m/s]			0.2		
FRECUENCIA: [Hz]			50		
TENSION: [V]		380V [Trifásica]			

04B-CUARTO DE MÁQUINAS

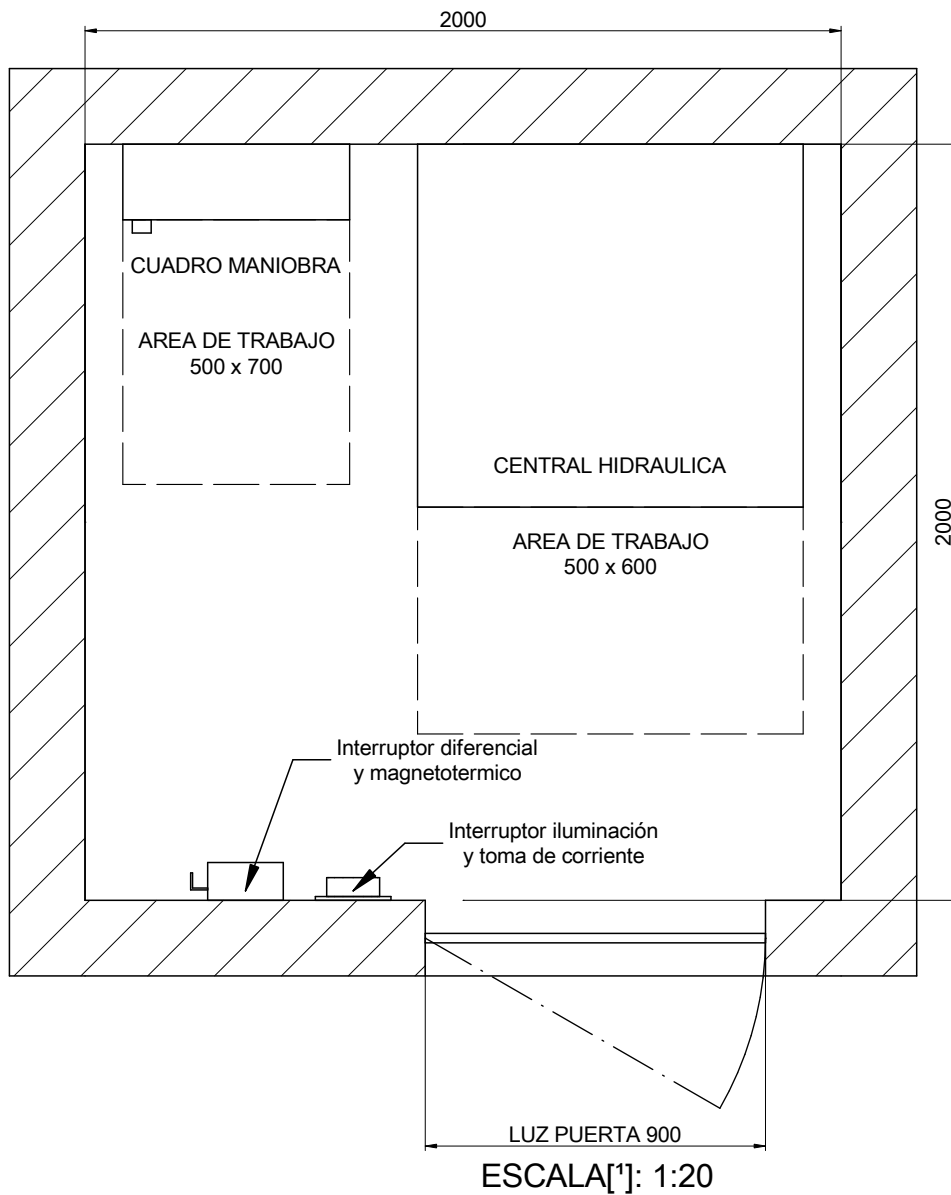

Altura mínima del cuarto de máquinas: 2100 mm.
 [EN 81-20:2014 5.2.6.3.2.1]
 Luz de puerta mínima: 600x2000 mm.
 [EN 81-20:2014 5.2.3.2 a)]

Situación cuarto de máquinas:
 Secuencia piso de sala de maquinas:
 [3] Distancia del cuadro al hueco:
 Ubicación de la toma de aceite del cilindro: 0

DIBUJADO	FECHA	REV.	HOJA	[*] Las dimensiones no acotadas en el plano son indicativas y no vinculantes.	
MP	2017	00	5/9	REFERENCIA: MPH_MONTACOCHEES_3500_ES	
MODELO ASCENSOR:				CLIENTE: SITUACION OBRA:	
MP H					
CAPACIDAD: [Nº PERSONAS]			46		
CARGA UTIL: [kg]			3500		
VELOCIDAD: [m/s]			0.2		
FRECUENCIA: [Hz]			50		
TENSION: [V]		380V [Trifásica]			
MP ASCENSORES					

05-PLANTA DE FOSO

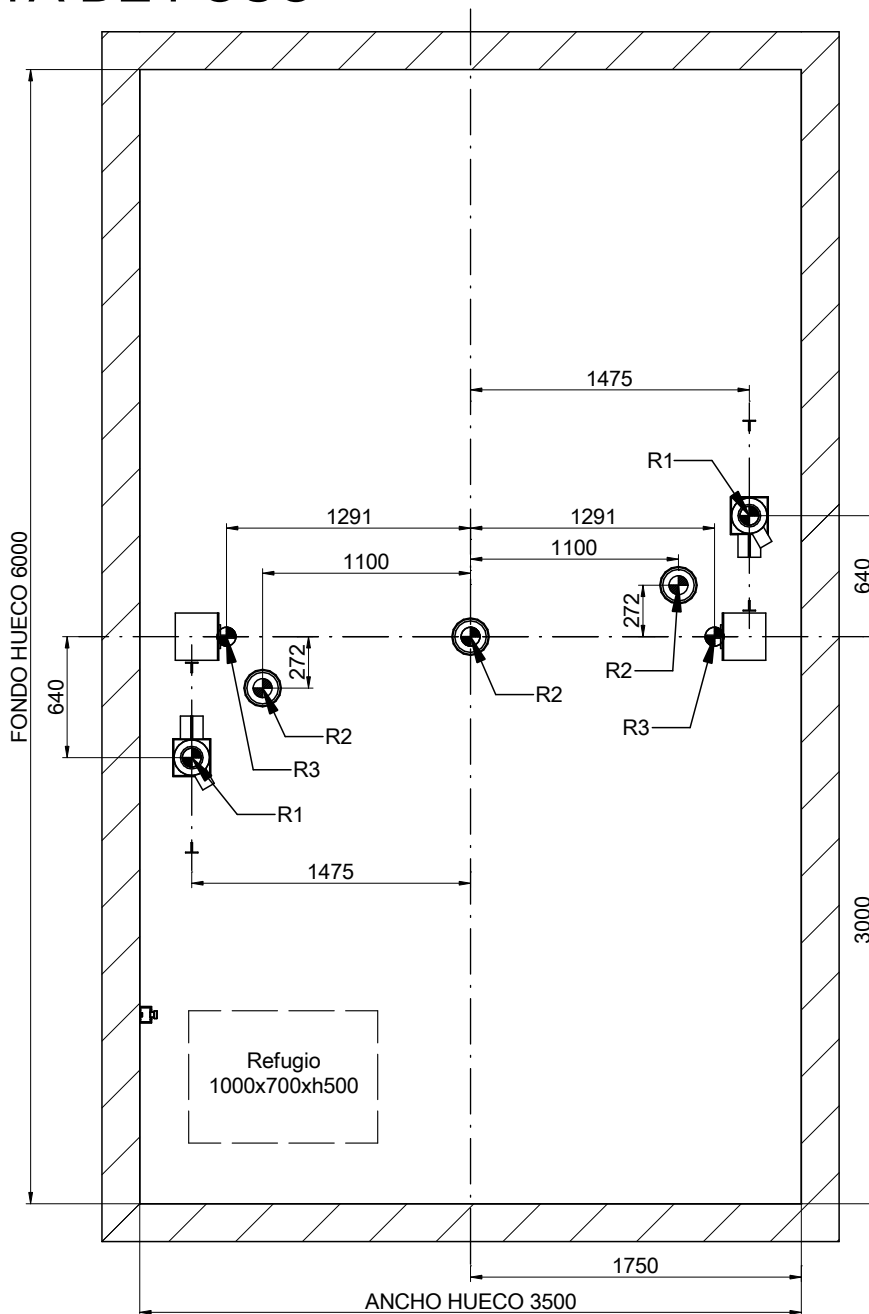

REACCIONES [N] [max.]			
R1	109000		
R2	72550	R3 103000	
Sx	10200	Sy 9325	

DIBUJADO	FECHA	REV.	HOJA	[*] Las dimensiones no acotadas en el plano son indicativas y no vinculantes.	
MP	2017	00	6/9	REFERENCIA: MPH_MONTACOCHEES_3500_ES	
MODELO ASCENSOR:				CLIENTE:	MP ASCENSORES
MP H				SITUACION OBRA:	
CAPACIDAD: [N° PERSONAS]		46			
CARGA UTIL: [kg]		3500			
VELOCIDAD: [m/s]		0.2			
FRECUENCIA: [Hz]		50			
TENSION: [V]		380V [Trifásica]			

06-DETALLE DE HUECO DE PUERTA

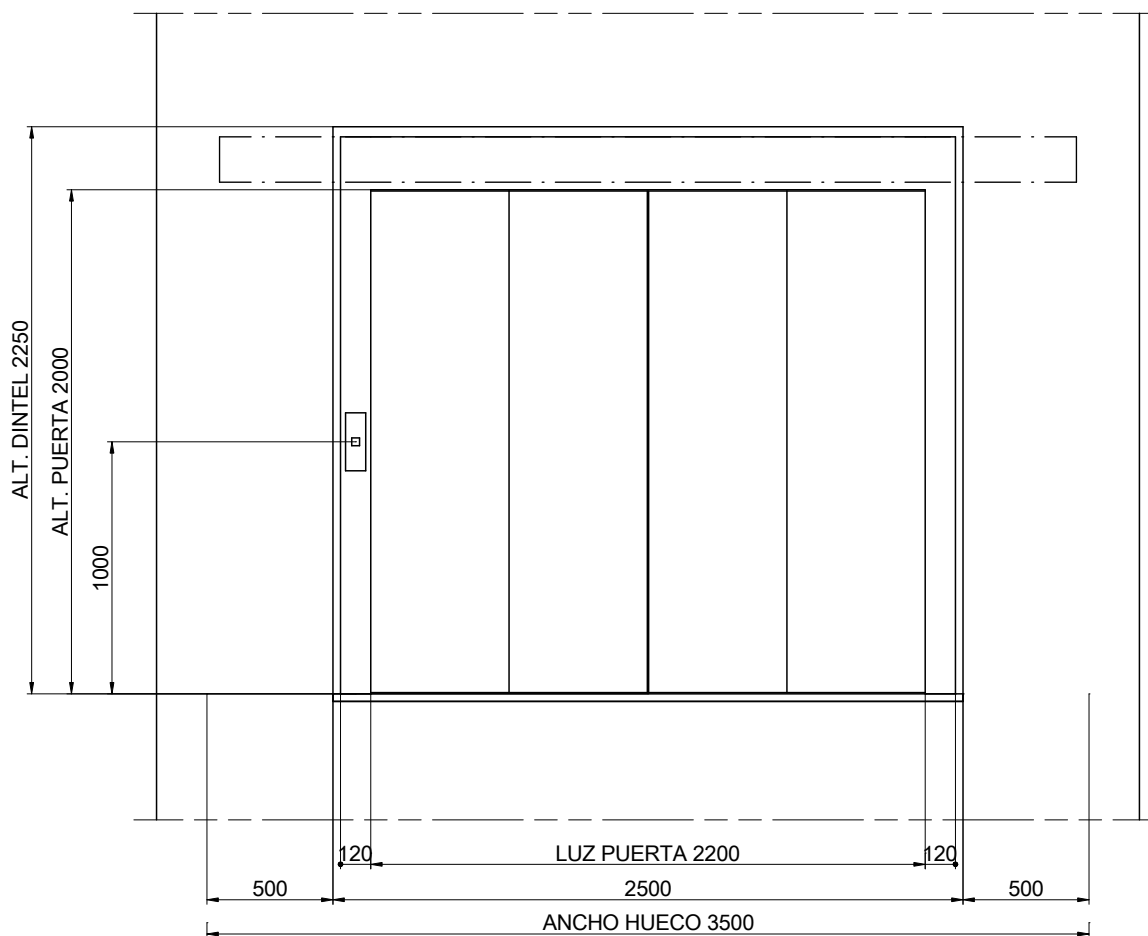

ESCALA[*]: 1:30

[2] Rebaje para largueros

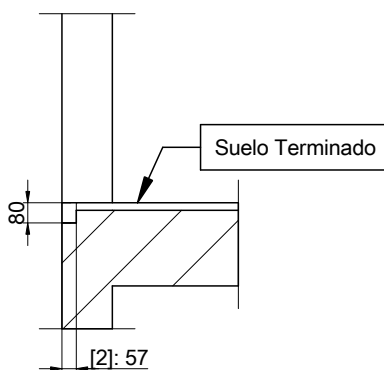

ESCALA[*]: 1:30

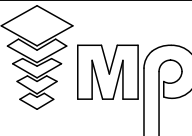
DIBUJADO	FECHA	REV.	HOJA	[*] Las dimensiones no acotadas en el plano son indicativas y no vinculantes.	
MP	2017	00	7/9	REFERENCIA: MPH_MONTACOCHEES_3500_ES	
MODELO ASCENSOR:				CLIENTE:	<p>MP ASCENSORES</p>
MP H				SITUACION OBRA:	
CAPACIDAD: [Nº PERSONAS]			46		
CARGA UTIL: [kg]			3500		
VELOCIDAD: [m/s]			0.2		
FRECUENCIA: [Hz]			50		
TENSION: [V]		380V [Trifásica]			

06B-DETALLE DE HUECO DE PUERTA

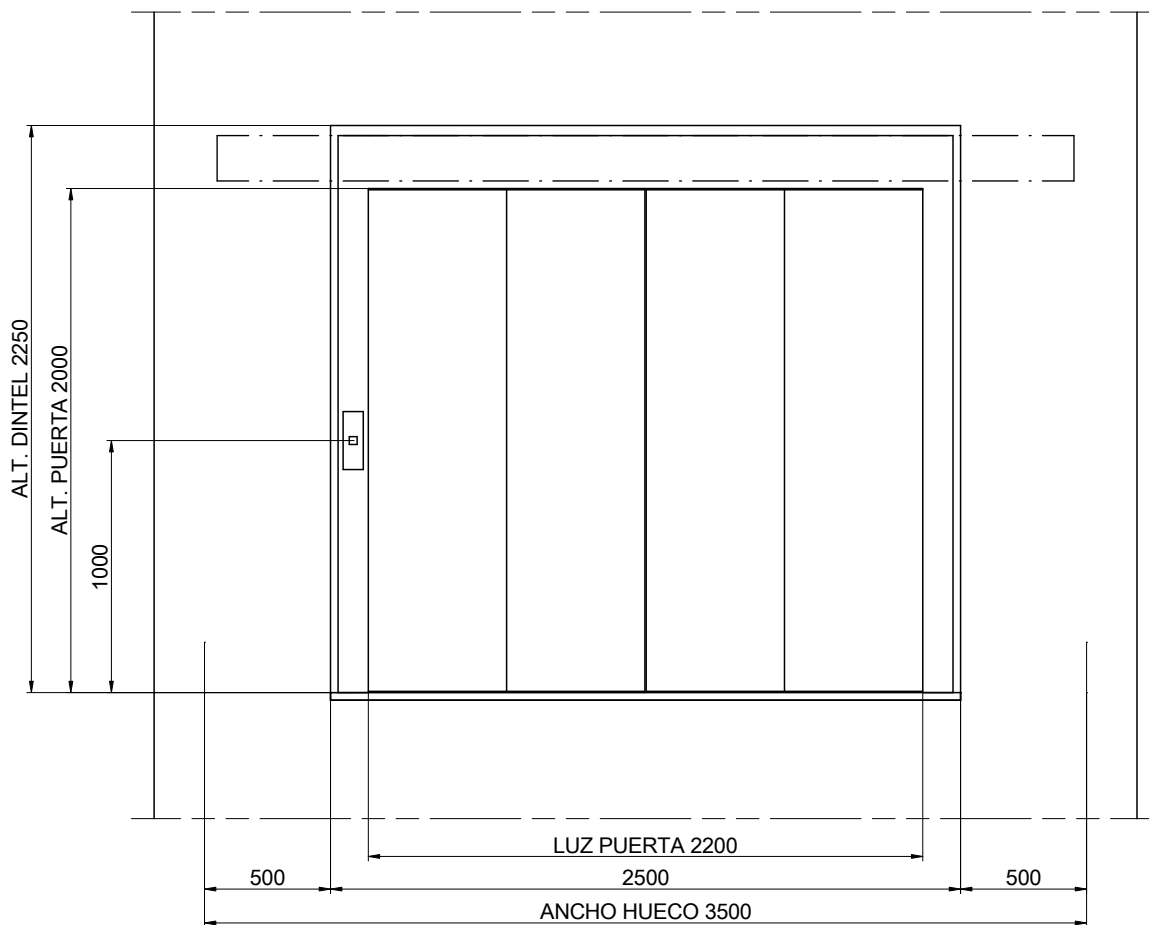

180 grados
ESCALA[*]: 1:30

[2] Rebaje para largueros

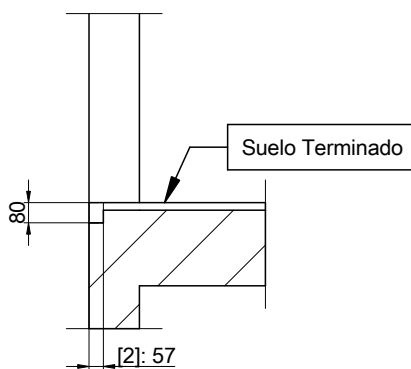

180 grados
ESCALA[*]: 1:30

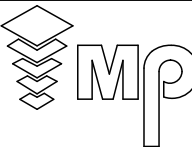
DIBUJADO	FECHA	REV.	HOJA	[*] Las dimensiones no acotadas en el plano son indicativas y no vinculantes.	
MP	2017	00	8/9		
MODELO ASCENSOR:				REFERENCIA:	<p>MP ASCENSORES</p>
MP H				MPH_MONTACOCHEES_3500_ES	
CAPACIDAD: [Nº PERSONAS]				CLIENTE:	<p>SITUACION OBRA:</p>
CARGA UTIL: [kg]					
VELOCIDAD: [m/s]					
FRECUENCIA: [Hz]					
TENSION: [V]					
380V [Trifásica]					

07-HUIDA

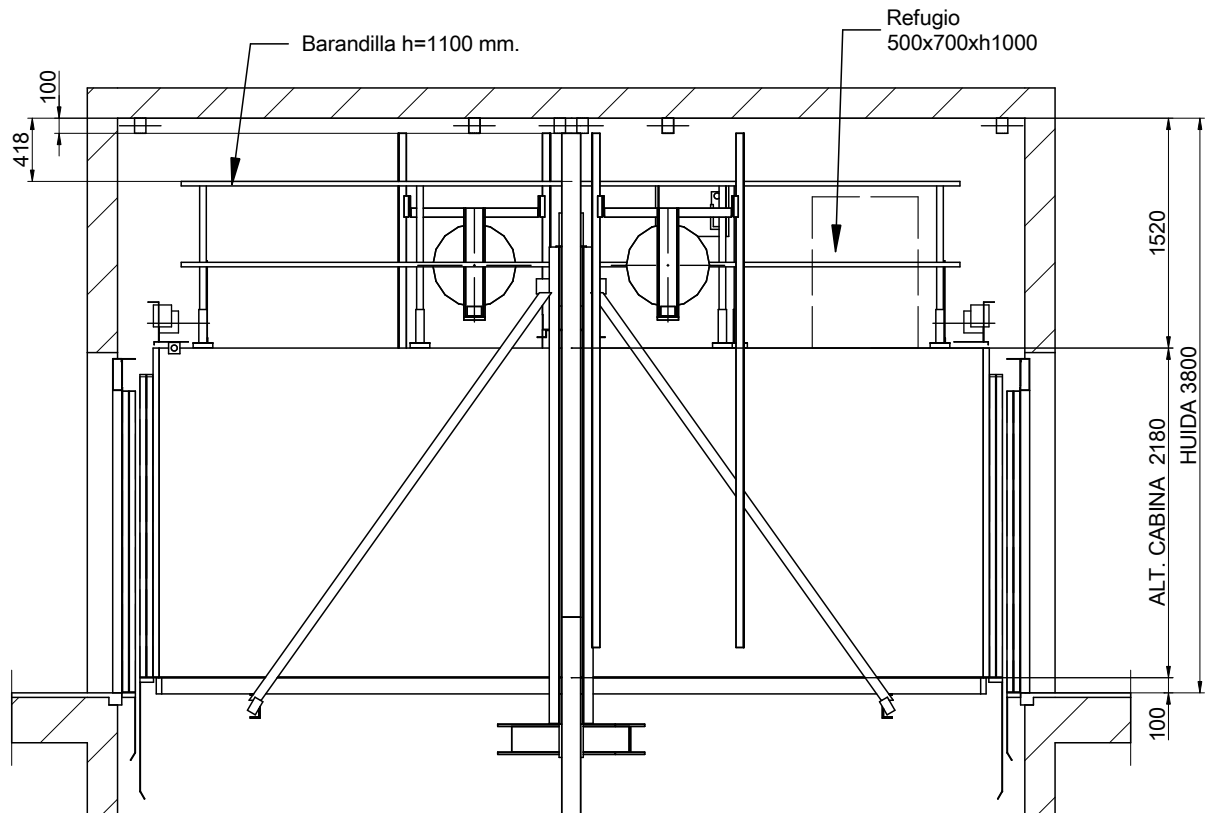

ESCALA[1]: 1:50

DIBUJADO	FECHA	REV.	HOJA	[*] Las dimensiones no acotadas en el plano son indicativas y no vinculantes.	
MP	2017	00	9/9	REFERENCIA: MPH_MONTACOCHEES_3500_ES	
MODELO ASCENSOR:				CLIENTE:	<p>SITUACION OBRA:</p> <p>MP ASCENSORES</p>
MP H					
CAPACIDAD: [Nº PERSONAS]			46		
CARGA UTIL: [kg]			3500		
VELOCIDAD: [m/s]			0.2		
FRECUENCIA: [Hz]			50		
TENSION: [V]		380V [Trifásica]			