

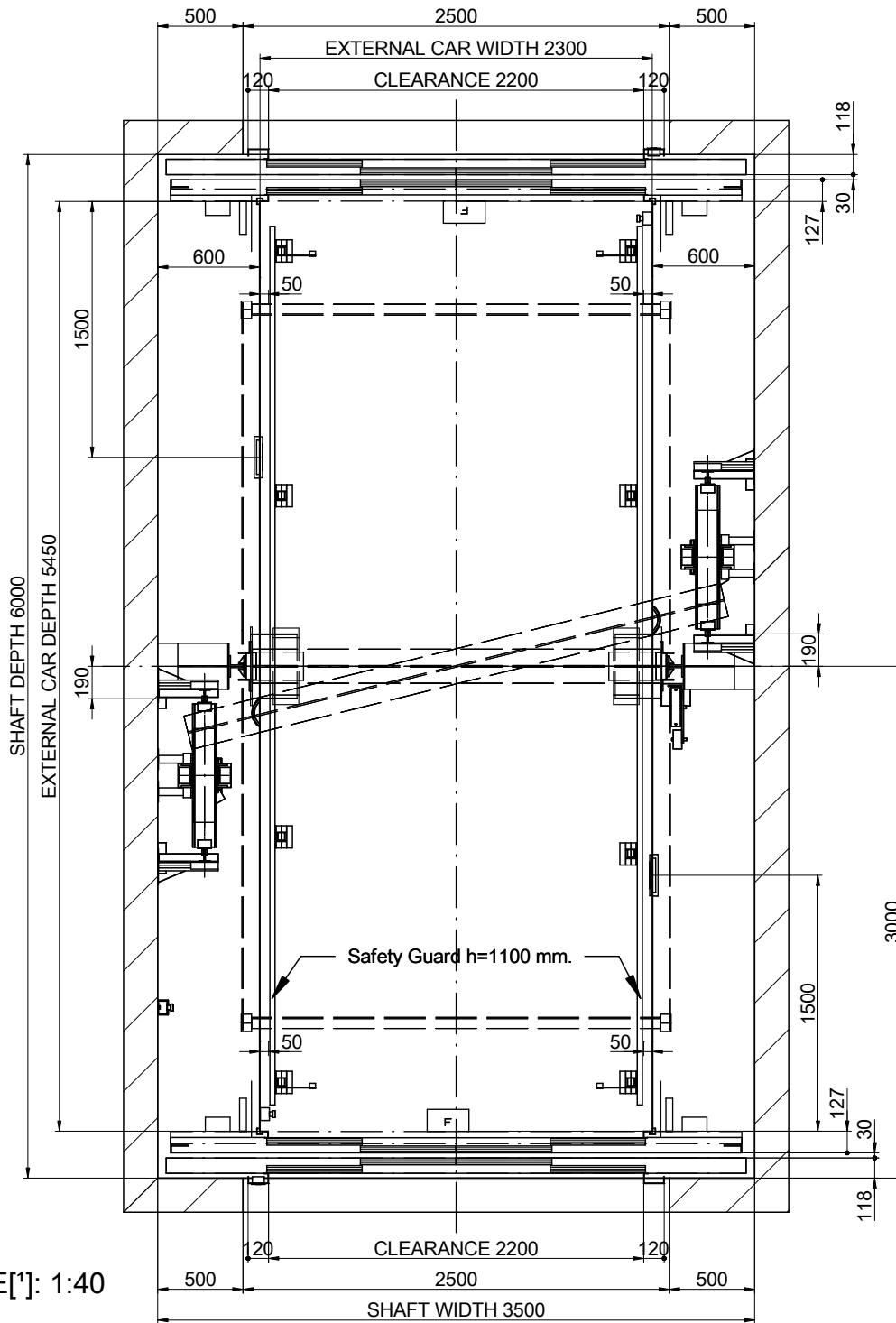

# 01-PLAN VIEW



SCALE[\*]: 1:40

DRAWING	DATE	REV.	SHEET	[*] Unbounded dimensions in drawings are indicative and not binding. REFERENCE: MPH_MONTACOCHEs_3500_EN	
MP	2017	00	1/9		
MODEL LIFT:				CLIENT:	WORK SITUATION:
MP H					
CAPACITY: [N° PERSONS]			46	<b>MP LIFTS</b>	
NOMINAL LOAD: [kg]			3500		
SPEED: [m/s]			0.2		
FREQUENCY: [Hz]			50		
TENSION: [V]			380V [Three-phase]		

# 01B-PLAN VIEW

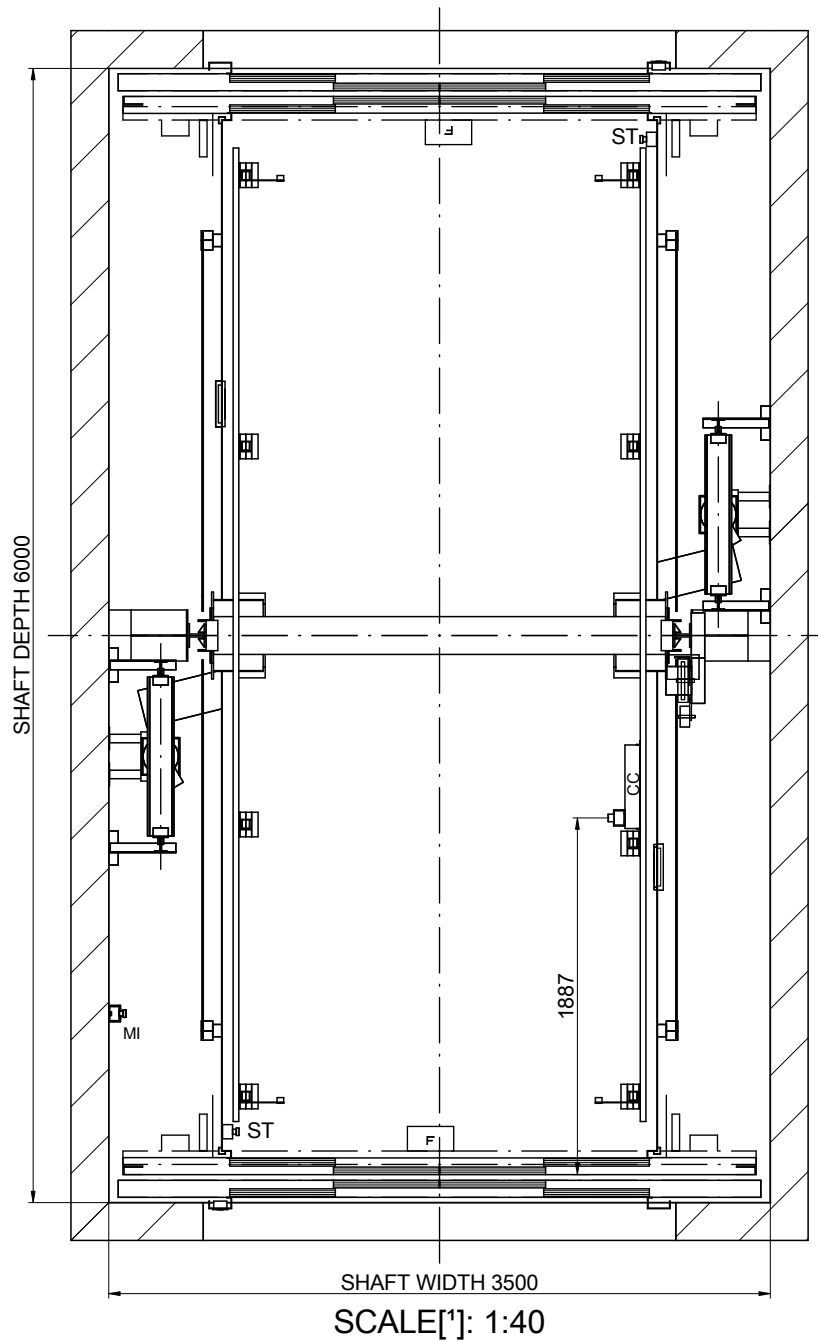

## NOMENCLATURE

CC: Car ceiling connection box

ST: Stopping device

MI: Inspection control station

DRAWING	DATE	REV.	SHEET	[*] Unbounded dimensions in drawings are indicative and not binding.	
MP	2017	00	2/9	REFERENCE: MPH_MONTACOCHEs_3500_EN	
MODEL LIFT:				CLIENT: WORK SITUATION:	<b>MP LIFTS</b>
<b>MP H</b>					
CAPACITY: [N° PERSONS]			46		
NOMINAL LOAD: [kg]			3500		
SPEED: [m/s]			0.2		
FREQUENCY: [Hz]			50		
TENSION: [V]		380V [Three-phase]			

# 02-SIDE VERTICAL SECTION

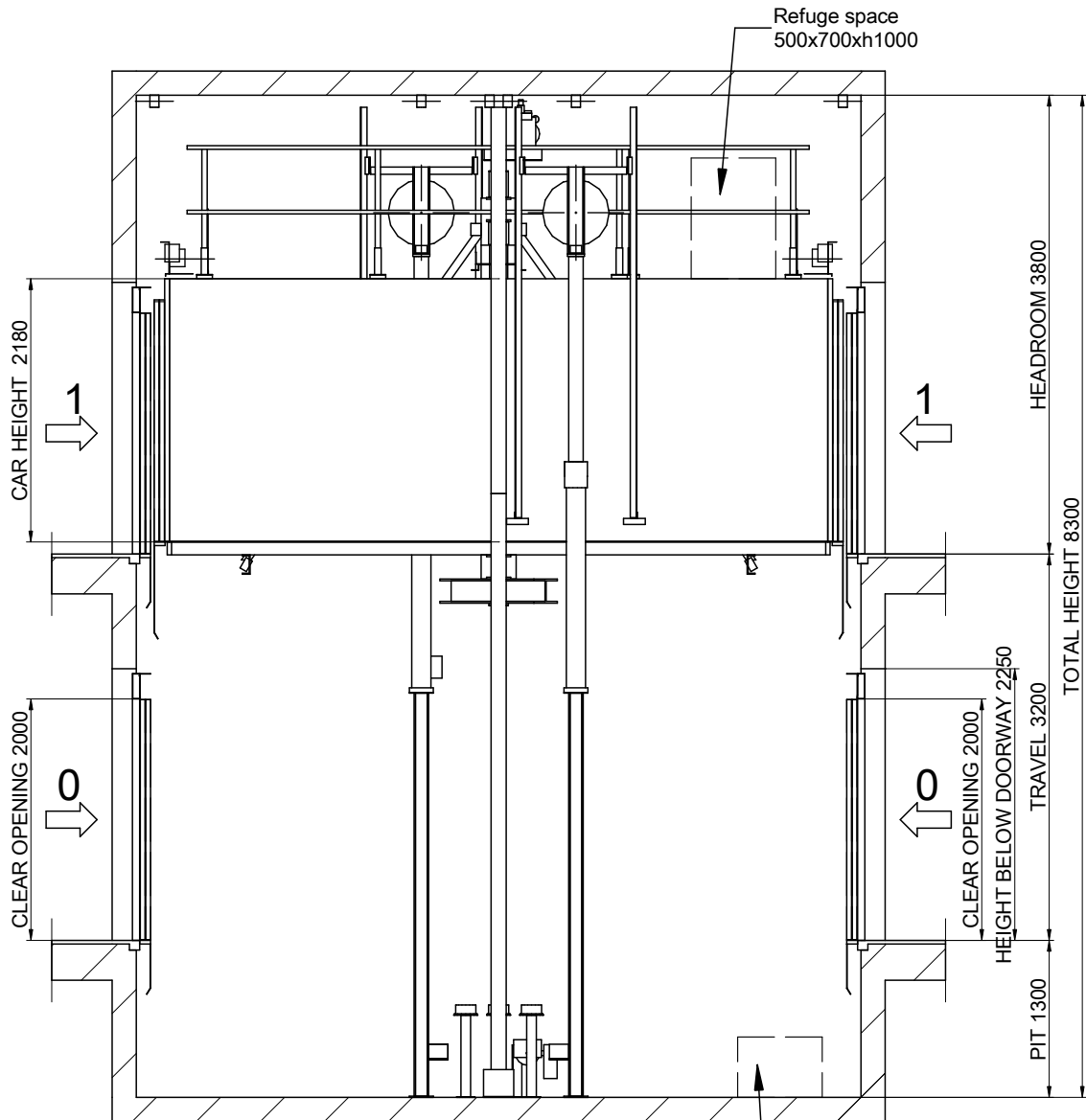

Flat and levelled floor, protected against water leaking.  
 [EN81-20:2014 5.2.1.9]  
 Foresee pit access device  
 [EN81-20:2014 5.2.2.4]  
 Stop device  
 [EN81-20:2014 5.2.1.5.1. a]  
 Inspection control station.  
 [EN81-20:2014 5.2.1.5.1. b]  
 Power supply  
 [EN81-20:2014 5.2.1.5.1. c]  
 Light swicht  
 commuted with the cabinet.  
 [EN81-20:2014 5.2.1.5.1. d]

SCALE[\*]: 1:60

Refuge space  
1000x700xh500

DRAWING	DATE	REV.	SHEET	[*] Unbounded dimensions in drawings are indicative and not binding.	
MP	2017	00	3/9	REFERENCE: MPH_MONTACOCHEs_3500_EN	
MODEL LIFT:				CLIENT:	<h2>MP LIFTS</h2>
MP H				WORK SITUATION:	
CAPACITY: [N° PERSONS]			46		
NOMINAL LOAD: [kg]			3500		
SPEED: [m/s]			0.2		
FREQUENCY: [Hz]			50		
TENSION: [V]		380V [Three-phase]			

# 04-BEAM AND LIFTING HOOKS

POSITION OF REMOVABLE LIFTING HOOKS ABLE TO SUPPORT  
3500 kg EACH ONE SUPPLIED BY CONSTRUCTOR  
(RECOMMENDED POSITION LOADHOOKS)

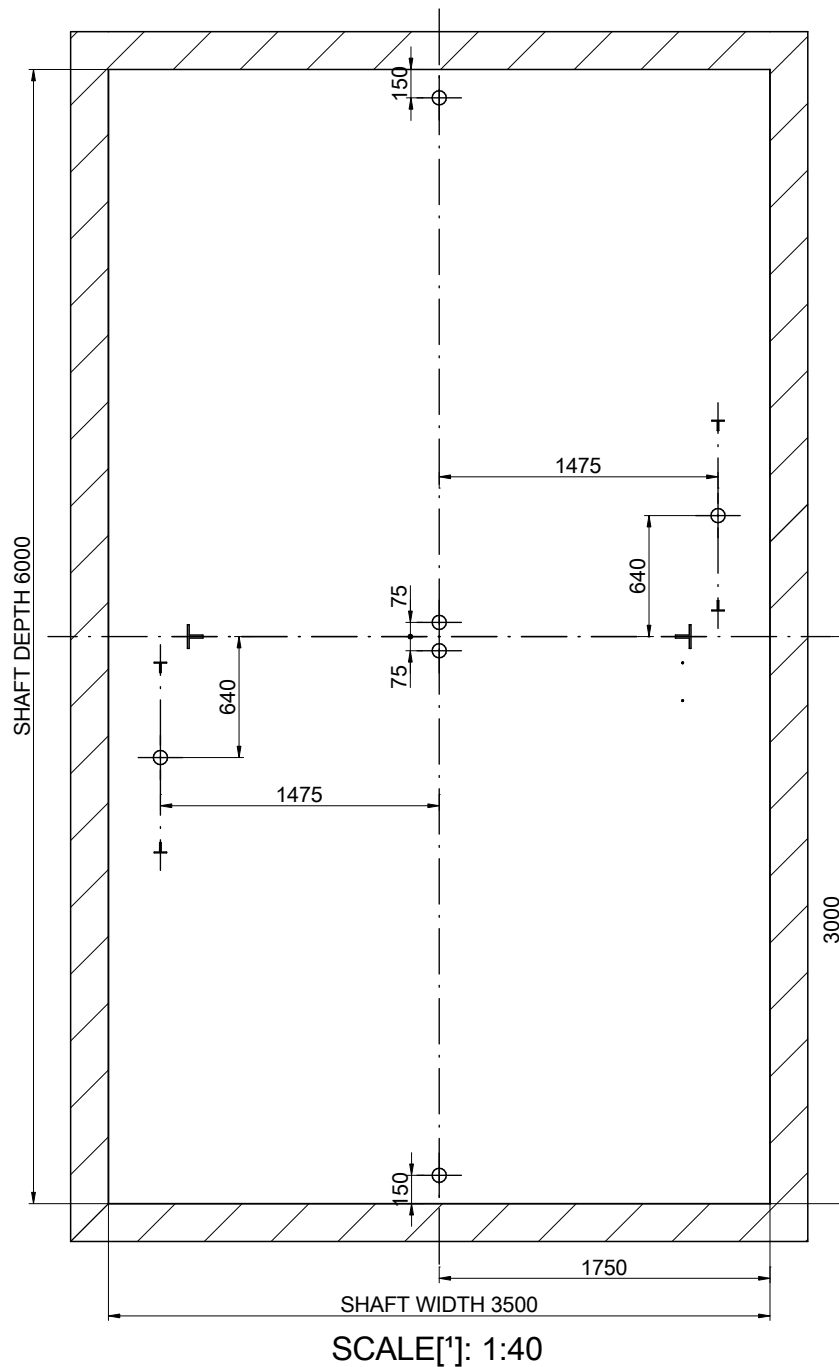

DRAWING	DATE	REV.	SHEET	[*] Unbounded dimensions in drawings are indicative and not binding.	
MP	2017	00	4/9	REFERENCE: MPH_MONTACOCHEs_3500_EN	
MODEL LIFT:				CLIENT:	<p><b>MP LIFTS</b></p>
<b>MP H</b>				WORK SITUATION:	
CAPACITY: [N° PERSONS]			46		
NOMINAL LOAD: [kg]			3500		
SPEED: [m/s]			0.2		
FREQUENCY: [Hz]			50		
TENSION: [V]		380V [Three-phase]			

# 04B-MACHINE ROOM

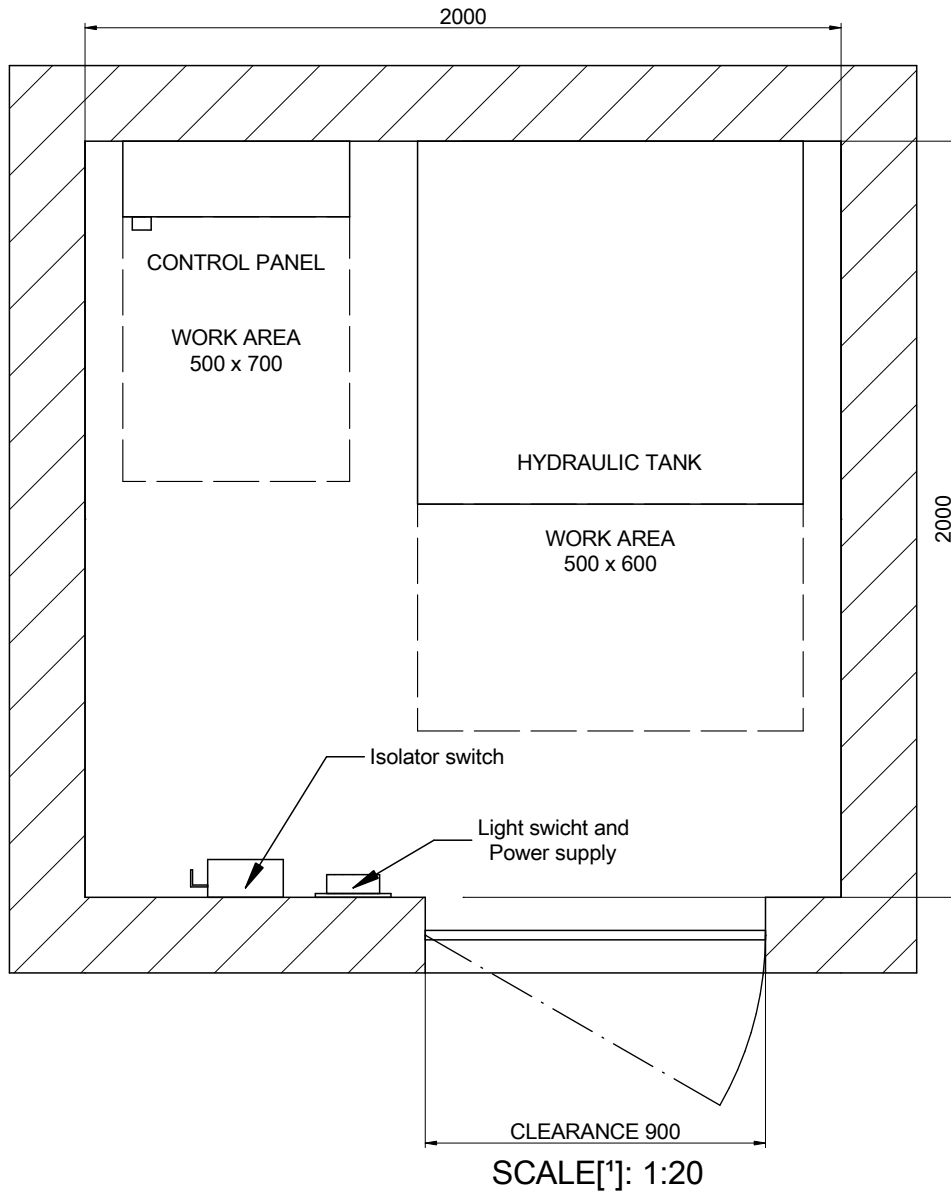

Minimum machine room height: 2100 mm.  
 [EN 81-20:2014 5.2.6.3.2.1]  
 Minimum clearance door: 600x2000 mm.  
 [EN 81-20:2014 5.2.3.2 a)]

Machine room location:  
 Machine room located in floor level:  
 [3] Distance controller/shaft:  
 Cylinder oil entrance location: 0

DRAWING	DATE	REV.	SHEET	[*] Unbounded dimensions in drawings are indicative and not binding.	
MP	2017	00	5/9	REFERENCE: MPH_MONTACOCHEs_3500_EN	
MODEL LIFT:				CLIENT: WORK SITUATION:	<p style="text-align: center; font-size: 2em; font-weight: bold;">MP LIFTS</p>
MP H					
CAPACITY: [N° PERSONS]		46			
NOMINAL LOAD: [kg]		3500			
SPEED: [m/s]		0.2			
FREQUENCY: [Hz]		50			
TENSION: [V]		380V [Three-phase]			

# 05-PIT LAYOUT

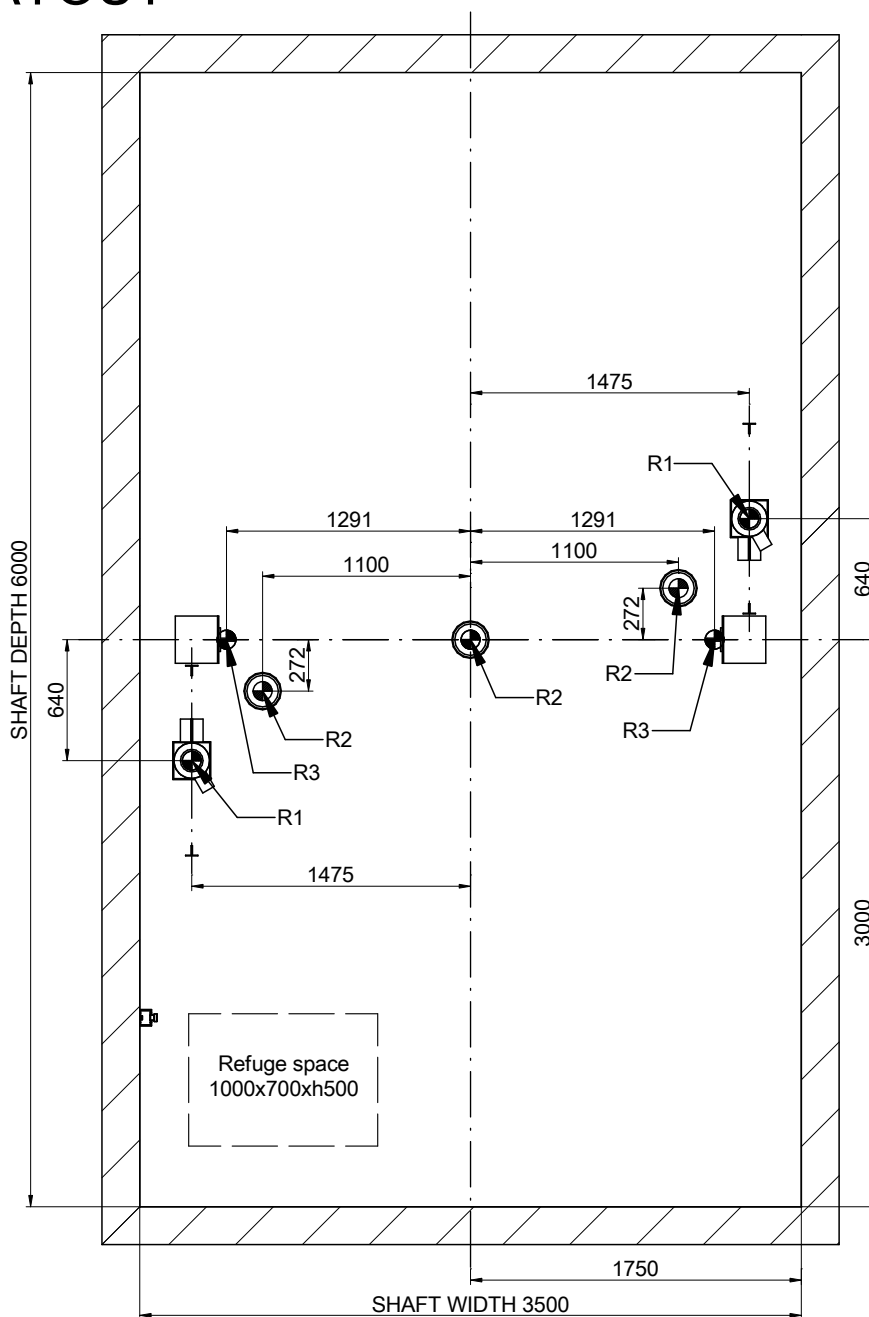

SCALE[\*]: 1:40

REACTIONS [N] [max.]			
R1	109000		
R2	72550	R3 103000	
Sx	10200	Sy 9325	

DRAWING	DATE	REV.	SHEET	[*] Unbounded dimensions in drawings are indicative and not binding.	
MP	2017	00	6/9	REFERENCE: MPH_MONTACOCHEs_3500_EN	
MODEL LIFT:				CLIENT: WORK SITUATION:	<p><b>MP LIFTS</b></p>
MP H					
CAPACITY: [N° PERSONS]			46		
NOMINAL LOAD: [kg]			3500		
SPEED: [m/s]			0.2		
FREQUENCY: [Hz]			50		
TENSION: [V]		380V [Three-phase]			

# 06-DOOR HOLE DETAIL

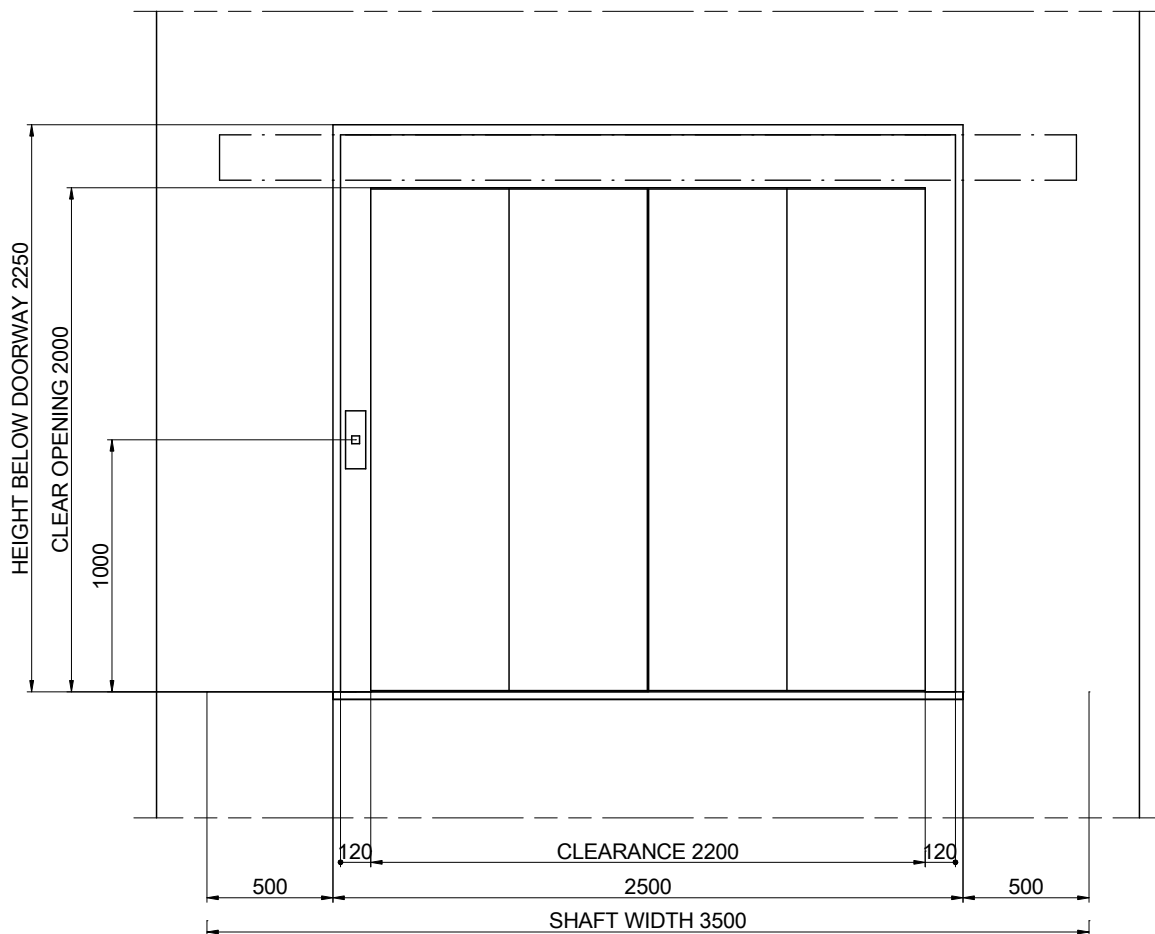

SCALE[\*]: 1:30

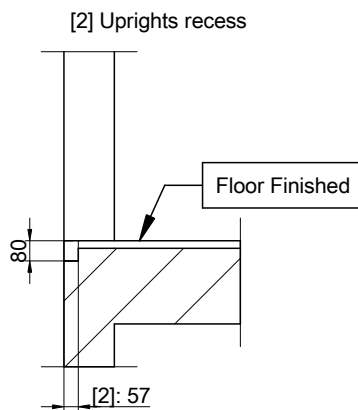

SCALE[\*]: 1:30

DRAWING	DATE	REV.	SHEET	[*] Unbounded dimensions in drawings are indicative and not binding. REFERENCE: MPH_MONTACOCHEs_3500_EN	
MP	2017	00	7/9		
MODEL LIFT:				CLIENT:	WORK SITUATION:
MP H					
CAPACITY: [N° PERSONS]		46		<h2>MP LIFTS</h2>	
NOMINAL LOAD: [kg]		3500			
SPEED: [m/s]		0.2			
FREQUENCY: [Hz]		50			
TENSION: [V]		380V [Three-phase]			

# 06B-DOOR HOLE DETAIL

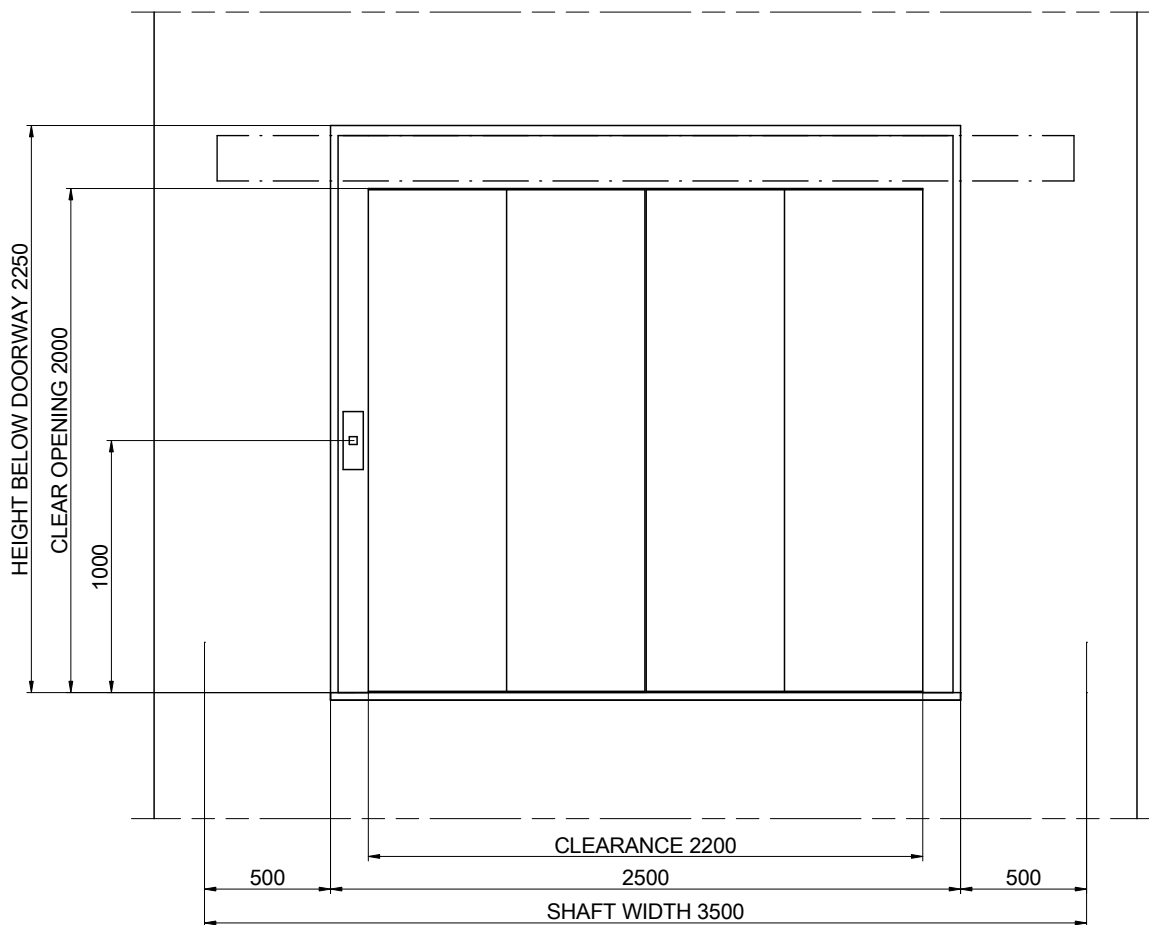

180 degrees  
 SCALE[\*]: 1:30

[2] Uprights recess

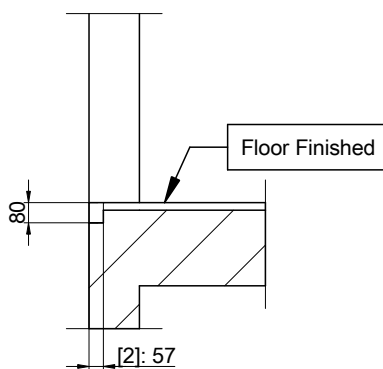

180 degrees  
 SCALE[\*]: 1:30

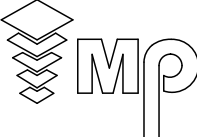
DRAWING	DATE	REV.	SHEET	[*] Unbounded dimensions in drawings are indicative and not binding. REFERENCE: MPH_MONTACOCHEs_3500_EN	
MP	2017	00	8/9		
MODEL LIFT:				CLIENT:	WORK SITUATION:
MP H					
CAPACITY: [N° PERSONS]		46		<b>MP LIFTS</b>	
NOMINAL LOAD: [kg]		3500			
SPEED: [m/s]		0.2			
FREQUENCY: [Hz]		50			
TENSION: [V]		380V [Three-phase]			



# 07-HEADROOM

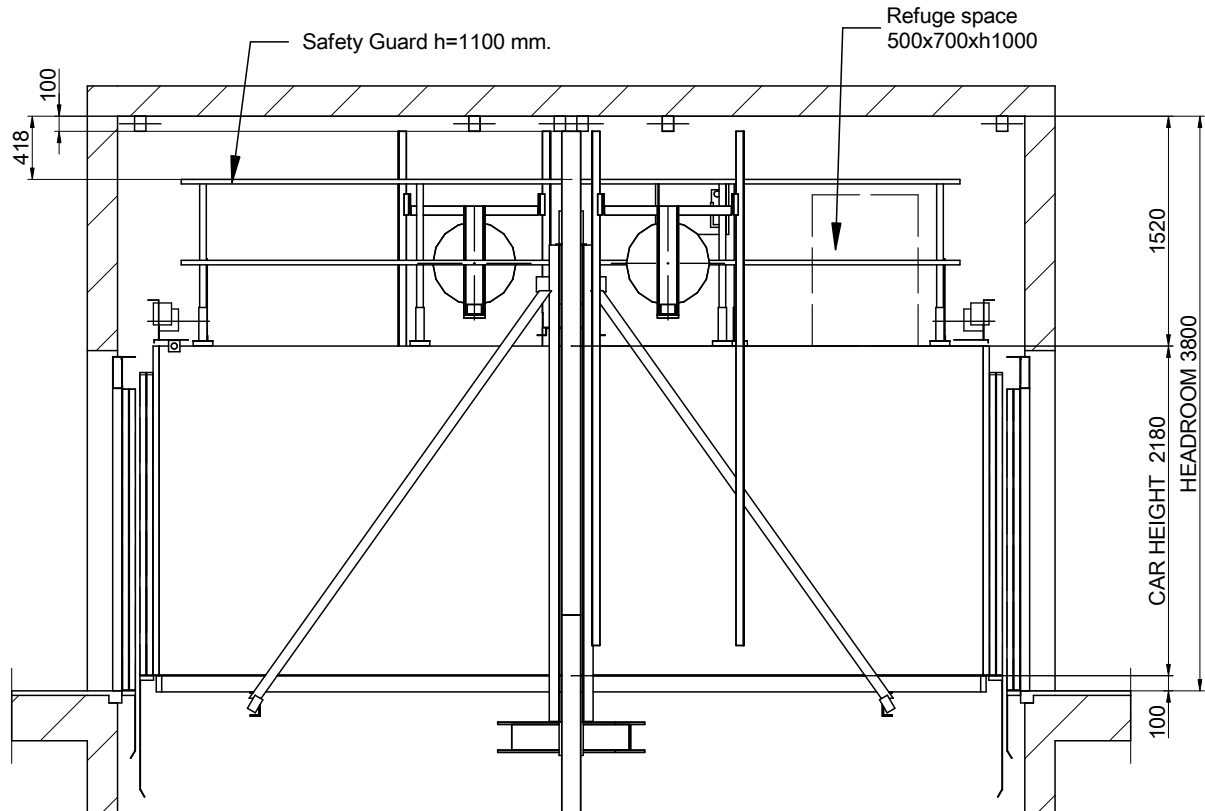

SCALE[\*]: 1:50

DRAWING	DATE	REV.	SHEET	[*] Unbounded dimensions in drawings are indicative and not binding.	
MP	2017	00	9/9		
MODEL LIFT:				REFERENCE: MPH_MONTACOCHEs_3500_EN	
MP H					
CAPACITY: [N° PERSONS]			46	CLIENT: WORK SITUATION:	
NOMINAL LOAD: [kg]			3500		
SPEED: [m/s]			0.2		
FREQUENCY: [Hz]			50		
TENSION: [V]			380V [Three-phase]		
				<b>MP LIFTS</b>	