

01-PLAN VIEW

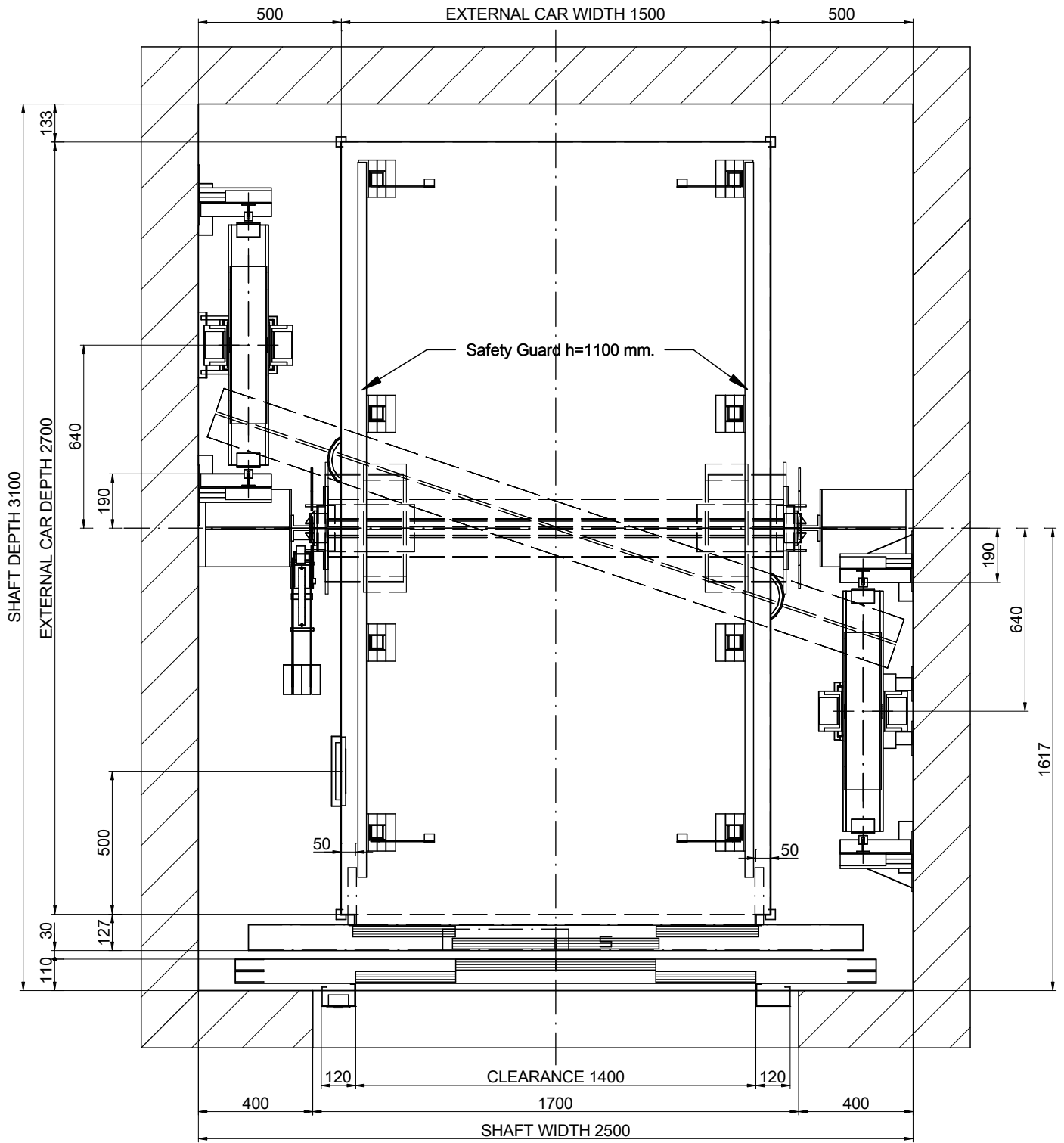

DRAWING	DATE	REV.	SHEET
MP	2017	00	1/8
MODEL LIFT:			
MP H			
CAPACITY: [N° PERSONS]			26
NOMINAL LOAD: [kg]			2000
SPEED: [m/s]			0.5
FREQUENCY: [Hz]			50
TENSION: [V]		380V [Three-phase]	

[*] Unbounded dimensions in drawings are indicative and not binding.

REFERENCE:
MPH_MONTACAMAS_2000C_EN

CLIENT:
WORK SITUATION:



MP LIFTS

01B-PLAN VIEW

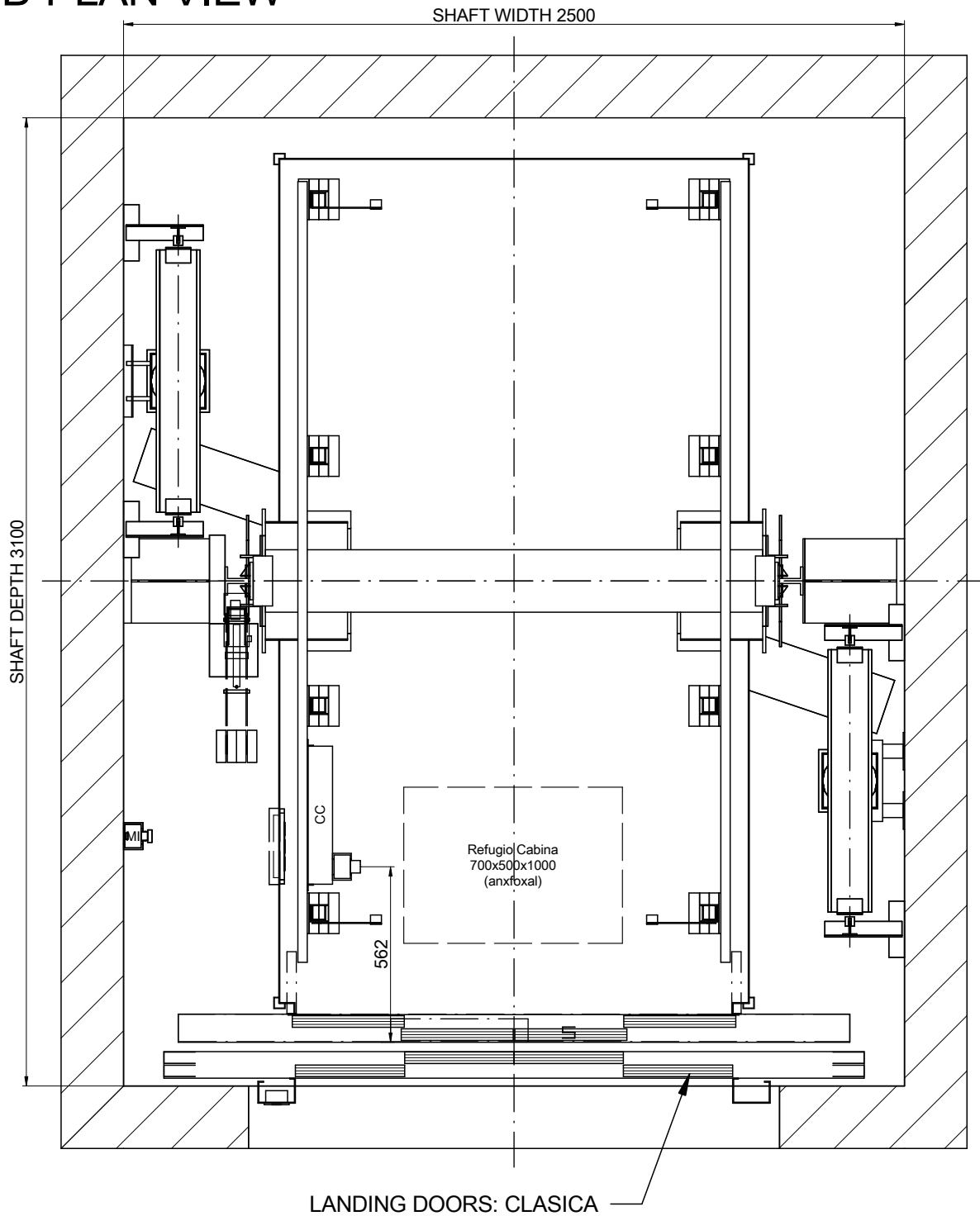



NOMENCLATURE
 CC: Car ceiling connection box
 MI: Inspection control station

SCALE[*]: 1:20

DRAWING	DATE	REV.	SHEET	[*] Unbounded dimensions in drawings are indicative and not binding. REFERENCE: MPH_MONTACAMAS_2000C_EN	
MP	2017	00	2/8		
MODEL LIFT:				CLIENT:	WORK SITUATION:
MP H					
CAPACITY: [N° PERSONS]			26	<p style="text-align: center; font-size: 24px; font-weight: bold;">MP LIFTS</p>	
NOMINAL LOAD: [kg]			2000		
SPEED: [m/s]			0.5		
FREQUENCY: [Hz]			50		
TENSION: [V]		380V [Three-phase]			

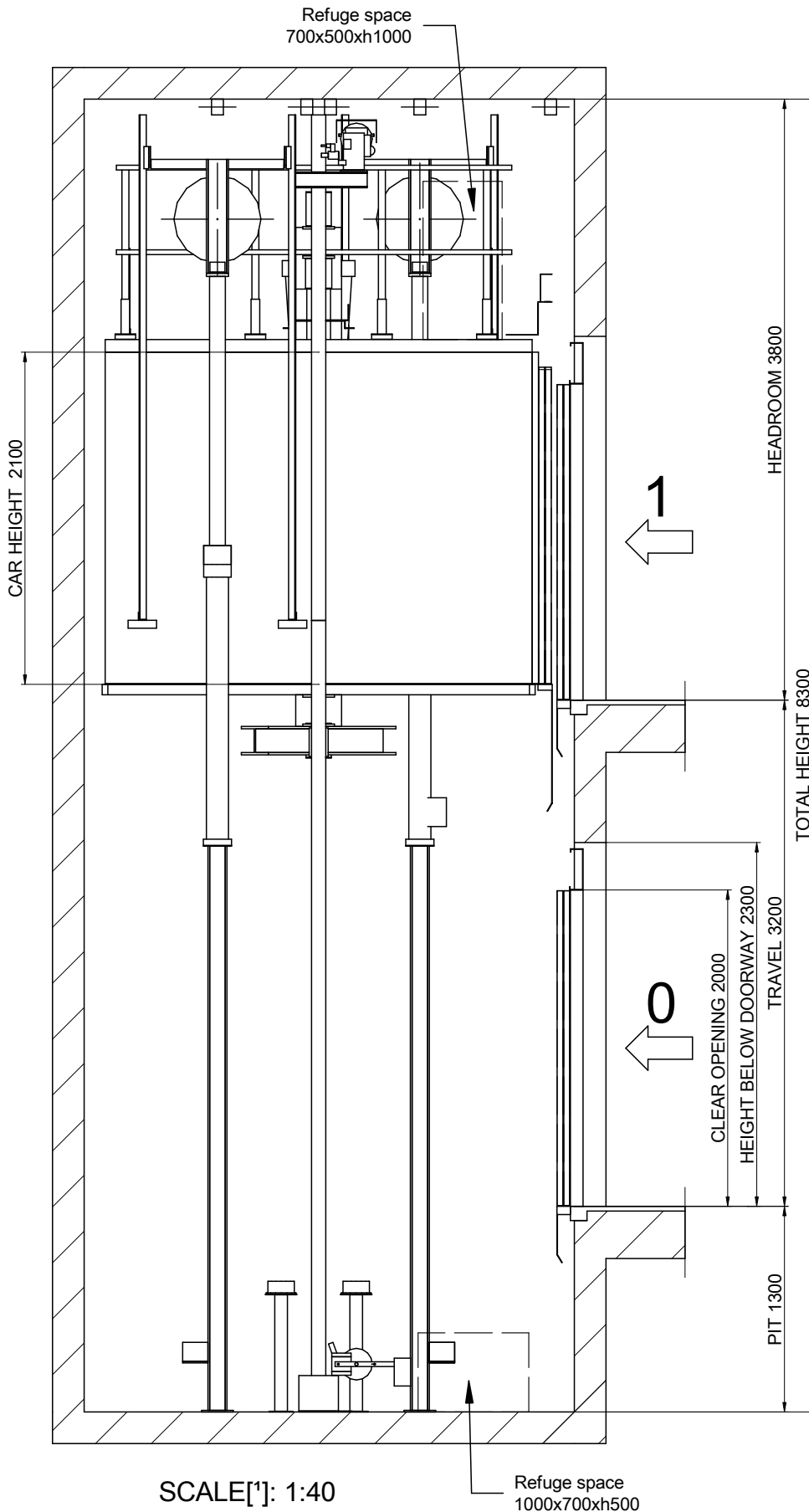
02-SIDE VERTICAL SECTION



		[*] Unbounded dimensions in drawings are indicative and not binding.	
		REFERENCE: MPH_MONTACAMAS_2000C_EN	
CLIENT: WORK SITUATION:		MP LIFTS	
DRAWING	DATE	REV.	SHEET
MP	2017	00	3/8
MODEL LIFT:		MP H	
CAPACITY: [N° PERSONS]		26	
NOMINAL LOAD: [kg]		2000	
SPEED: [m/s]		0.5	
FREQUENCY: [Hz]		50	
TENSION: [V]		380V [Three-phase]	

Flat and levelled floor, protected against water leaking.
 [EN81-20:2014 5.2.1.9]
 Foresee pit access device
 [EN81-20:2014 5.2.2.4]
 Stop device
 [EN81-20:2014 5.2.1.5.1. a]
 Inspection control station.
 [EN81-20:2014 5.2.1.5.1. b]
 Power supply
 [EN81-20:2014 5.2.1.5.1. c]
 Light switch
 commuted with the cabinet.
 [EN81-20:2014 5.2.1.5.1. d]



MAX DISTANCE
 BETWEEN BRACKETS
 = 1500 mm

04-BEAM AND LIFTING HOOKS

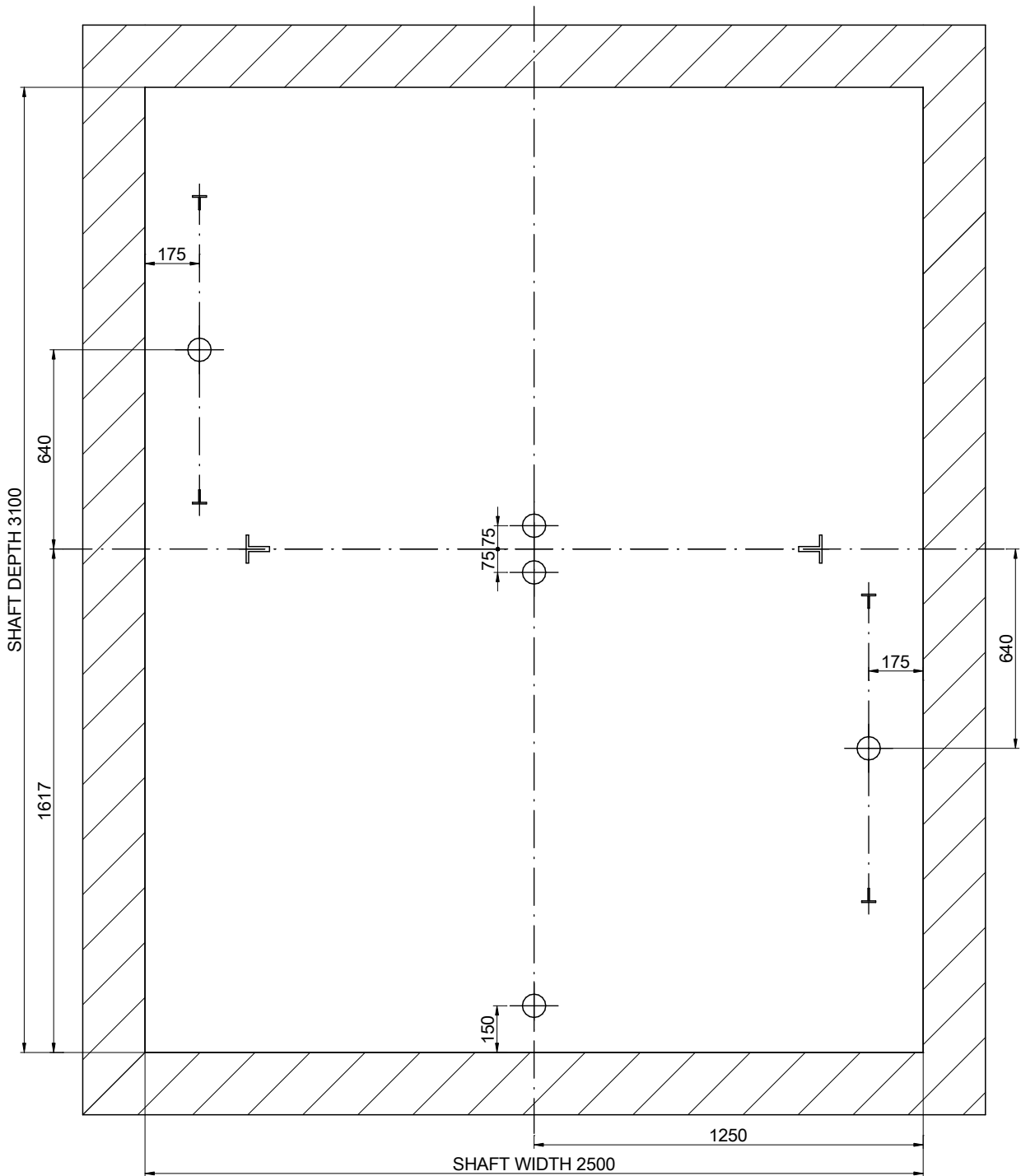
POSITION OF REMOVABLE LIFTING HOOKS ABLE TO SUPPORT
2000 kg EACH ONE SUPPLIED BY CONSTRUCTOR
(RECOMMENDED POSITION LOADHOOKS)



SCALE[*]: 1:20

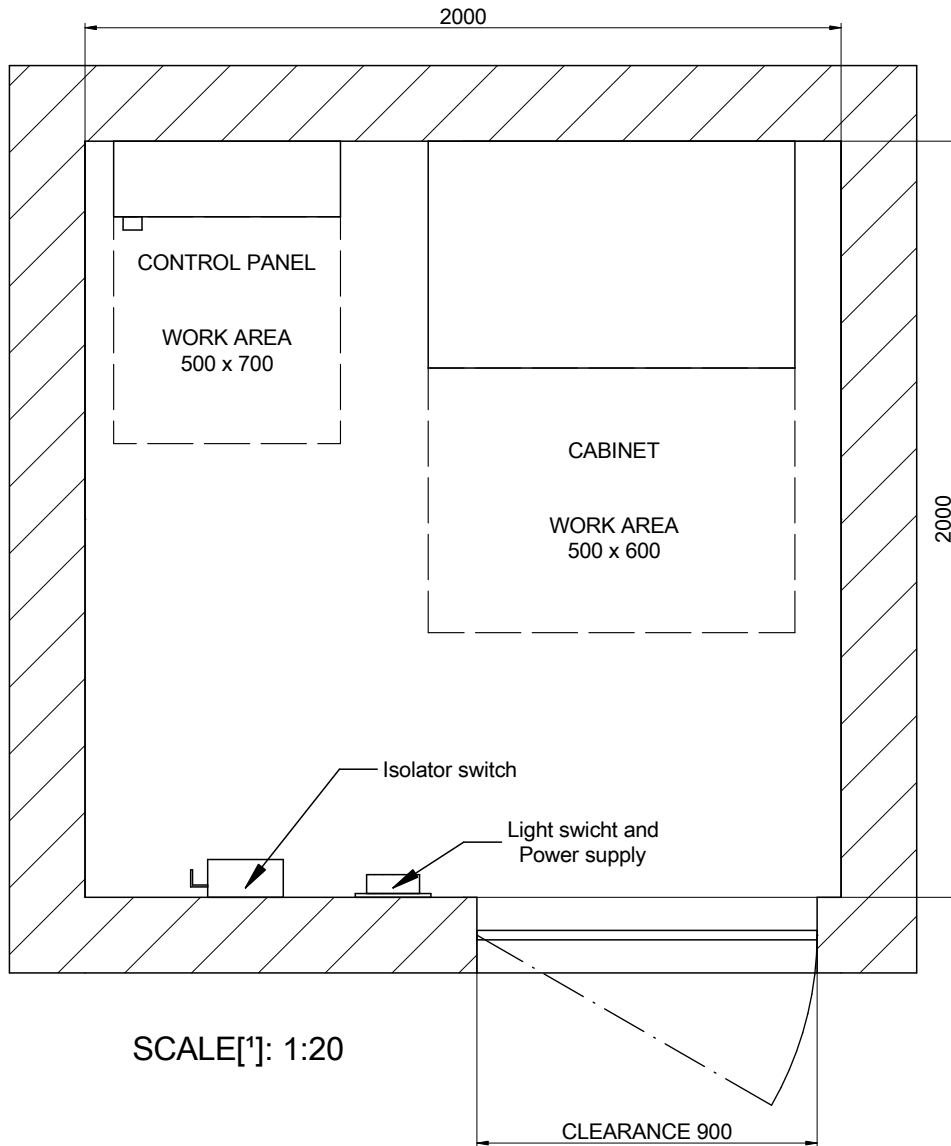

DRAWING	DATE	REV.	SHEET	[*] Unbounded dimensions in drawings are indicative and not binding.	
MP	2017	00	4/8	REFERENCE: MPH_MONTACAMAS_2000C_EN	
MODEL LIFT:				CLIENT: WORK SITUATION:	
MP H					
CAPACITY: [N° PERSONS]		26			
NOMINAL LOAD: [kg]		2000			
SPEED: [m/s]		0.5			
FREQUENCY: [Hz]		50			
TENSION: [V]		380V [Three-phase]		MP LIFTS	

04B-MACHINE ROOM



Minimum machine room height: 2100 mm.
[EN 81-20:2014 5.2.6.3.2.1]
Minimum clearance door: 600x2000 mm.
[EN 81-20:2014 5.2.3.2 a)]

Machine room location:
Machine room located in floor level:
[3] Distance controller/shaft:
Cylinder oil entrance location: 0

DRAWING	DATE	REV.	SHEET	[*] Unbounded dimensions in drawings are indicative and not binding.	
MP	2017	00	5/8	REFERENCE: MPH_MONTACAMAS_2000C_EN	
MODEL LIFT:				CLIENT: WORK SITUATION:	
MP H					
CAPACITY: [N° PERSONS]		26			
NOMINAL LOAD: [kg]		2000			
SPEED: [m/s]		0.5			
FREQUENCY: [Hz]		50			
TENSION: [V]		380V [Three-phase]		MP LIFTS	

05-PIT LAYOUT

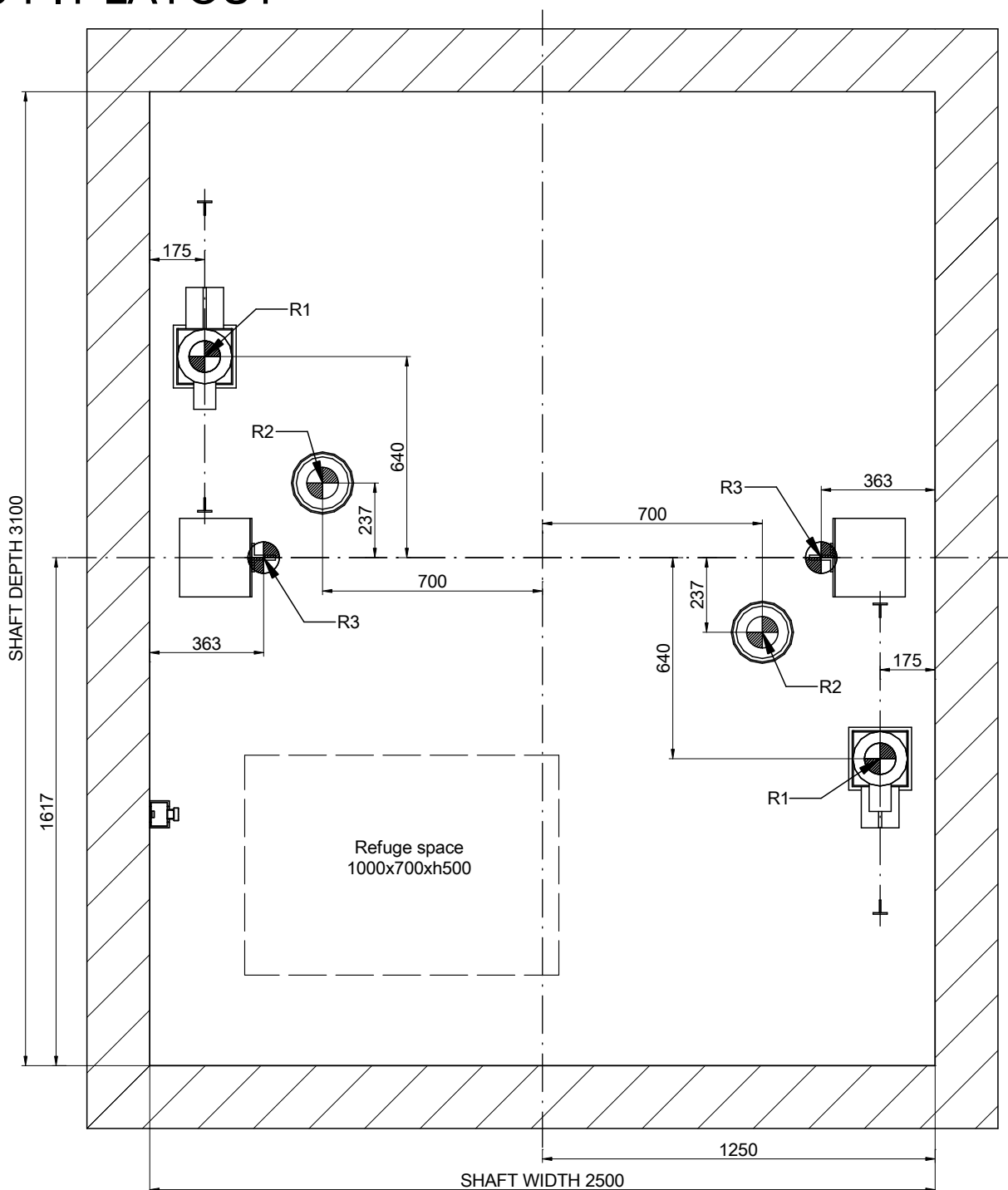



SCALE[*]: 1:20

REACTIONS [N] [max.]			
R1	55400	R2	69500
R3	55500		
Sx	4000	Sy	4500

DRAWING	DATE	REV.	SHEET	[*] Unbounded dimensions in drawings are indicative and not binding.	
MP	2017	00	6/8	REFERENCE: MPH_MONTACAMAS_2000C_EN	
MODEL LIFT:				CLIENT:	
MP H				WORK SITUATION:	
CAPACITY: [N° PERSONS]		26			
NOMINAL LOAD: [kg]		2000			
SPEED: [m/s]		0.5			
FREQUENCY: [Hz]		50			
TENSION: [V]		380V [Three-phase]			
				MP LIFTS	

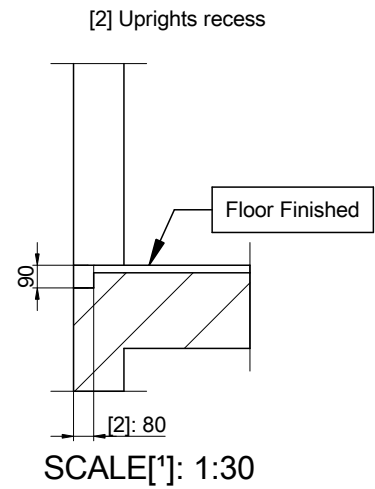
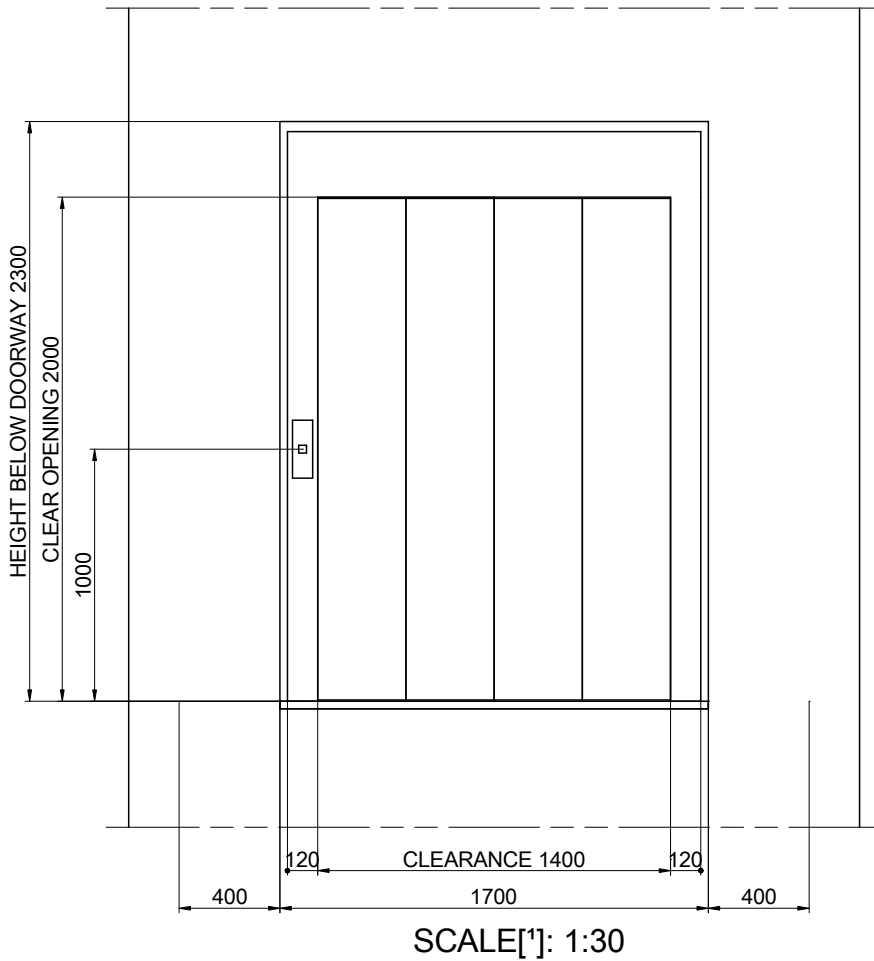
06-DOOR HOLE DETAIL



DRAWING	DATE	REV.	SHEET	[*] Unbounded dimensions in drawings are indicative and not binding.	
MP	2017	00	7/8	REFERENCE: MPH_MONTACAMAS_2000C_EN	
MODEL LIFT:				CLIENT: WORK SITUATION:	
MP H					
CAPACITY: [N° PERSONS]		26			
NOMINAL LOAD: [kg]		2000			
SPEED: [m/s]		0.5			
FREQUENCY: [Hz]		50			
TENSION: [V]		380V [Three-phase]		MP LIFTS	

07-HEADROOM

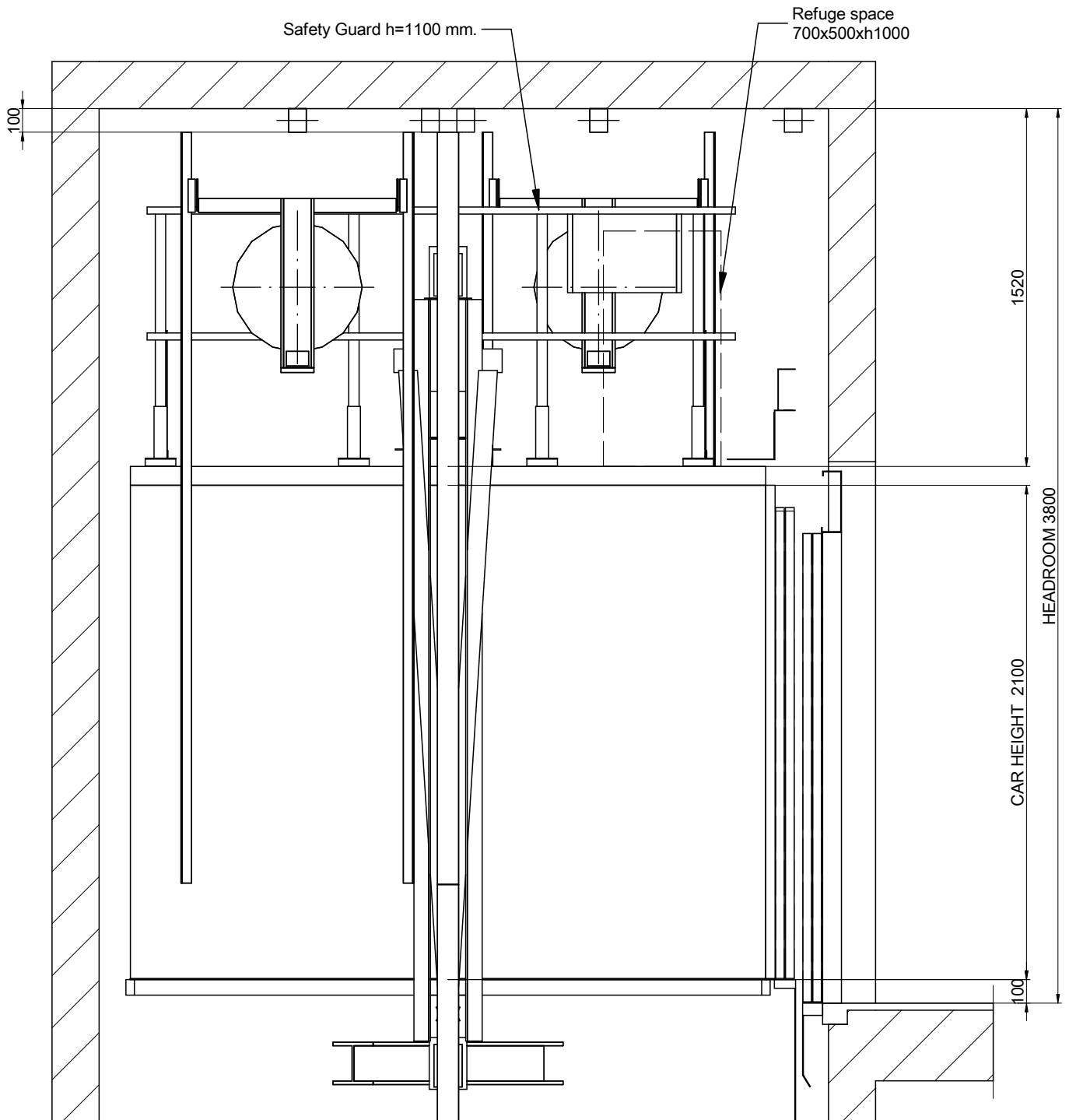

SCALE[*]: 1:25

DRAWING	DATE	REV.	SHEET	[*] Unbounded dimensions in drawings are indicative and not binding. REFERENCE: MPH_MONTACAMAS_2000C_EN	
MP	2017	00	8/8		
MODEL LIFT:				CLIENT:	WORK SITUATION:
MP H					
CAPACITY: [N° PERSONS]		26		MP LIFTS	
NOMINAL LOAD: [kg]		2000			
SPEED: [m/s]		0.5			
FREQUENCY: [Hz]		50			
TENSION: [V]		380V [Three-phase]			