

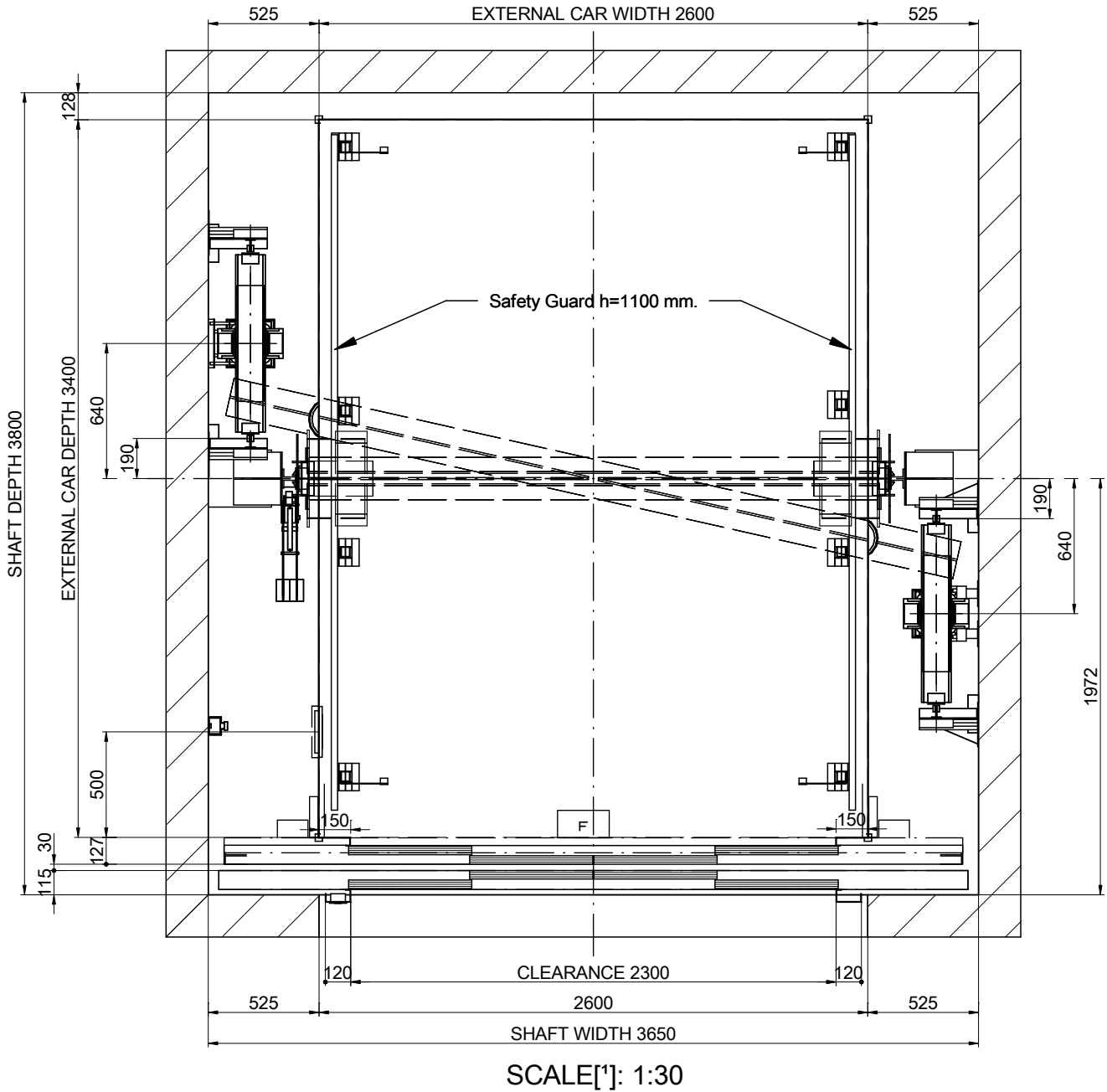

# 01-PLAN VIEW



DRAWING	DATE	REV.	SHEET	[*] Unbounded dimensions in drawings are indicative and not binding. REFERENCE: MPH_MONTACARGAS_5000_EN	
MP	2017	00	1/8		
MODEL LIFT:				CLIENT: WORK SITUATION:	
MP H					
CAPACITY: [N° PERSONS]		66		<b>MP LIFTS</b>	
NOMINAL LOAD: [kg]		5000			
SPEED: [m/s]		0.5			
FREQUENCY: [Hz]		50			
TENSION: [V]		380V [Three-phase]			

# 01B-PLAN VIEW

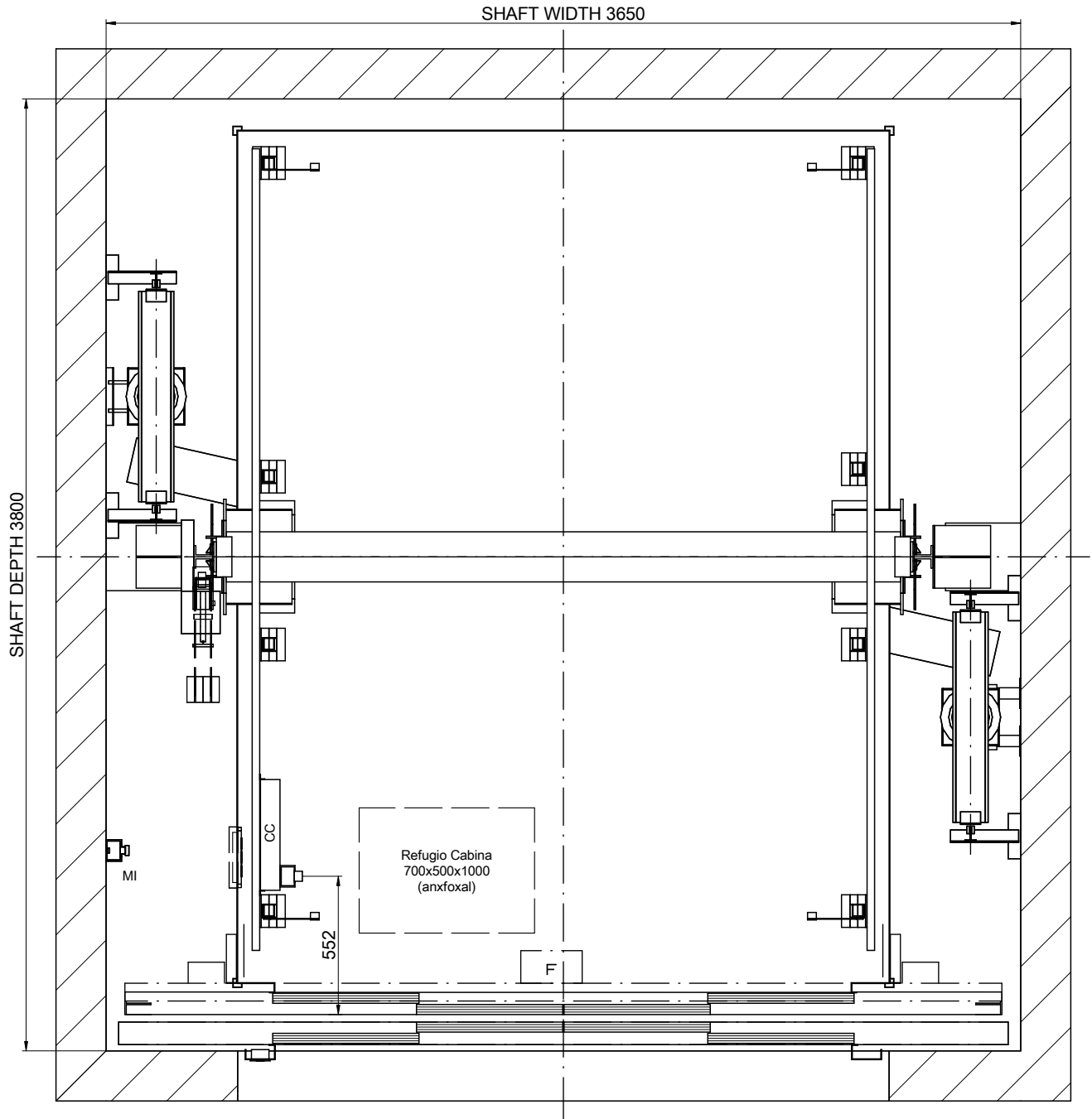

SCALE[\*]: 1:25

## NOMENCLATURE

CC: Car ceiling connection box  
MI: Inspection control station

DRAWING	DATE	REV.	SHEET	[*] Unbounded dimensions in drawings are indicative and not binding. REFERENCE: MPH_MONTACARGAS_5000_EN	
MP	2017	00	2/8		
MODEL LIFT:				CLIENT:	WORK SITUATION:
MP H					
CAPACITY: [N° PERSONS]		66		<b>MP LIFTS</b>	
NOMINAL LOAD: [kg]		5000			
SPEED: [m/s]		0.5			
FREQUENCY: [Hz]		50			
TENSION: [V]		380V [Three-phase]			

# 02-SIDE VERTICAL SECTION

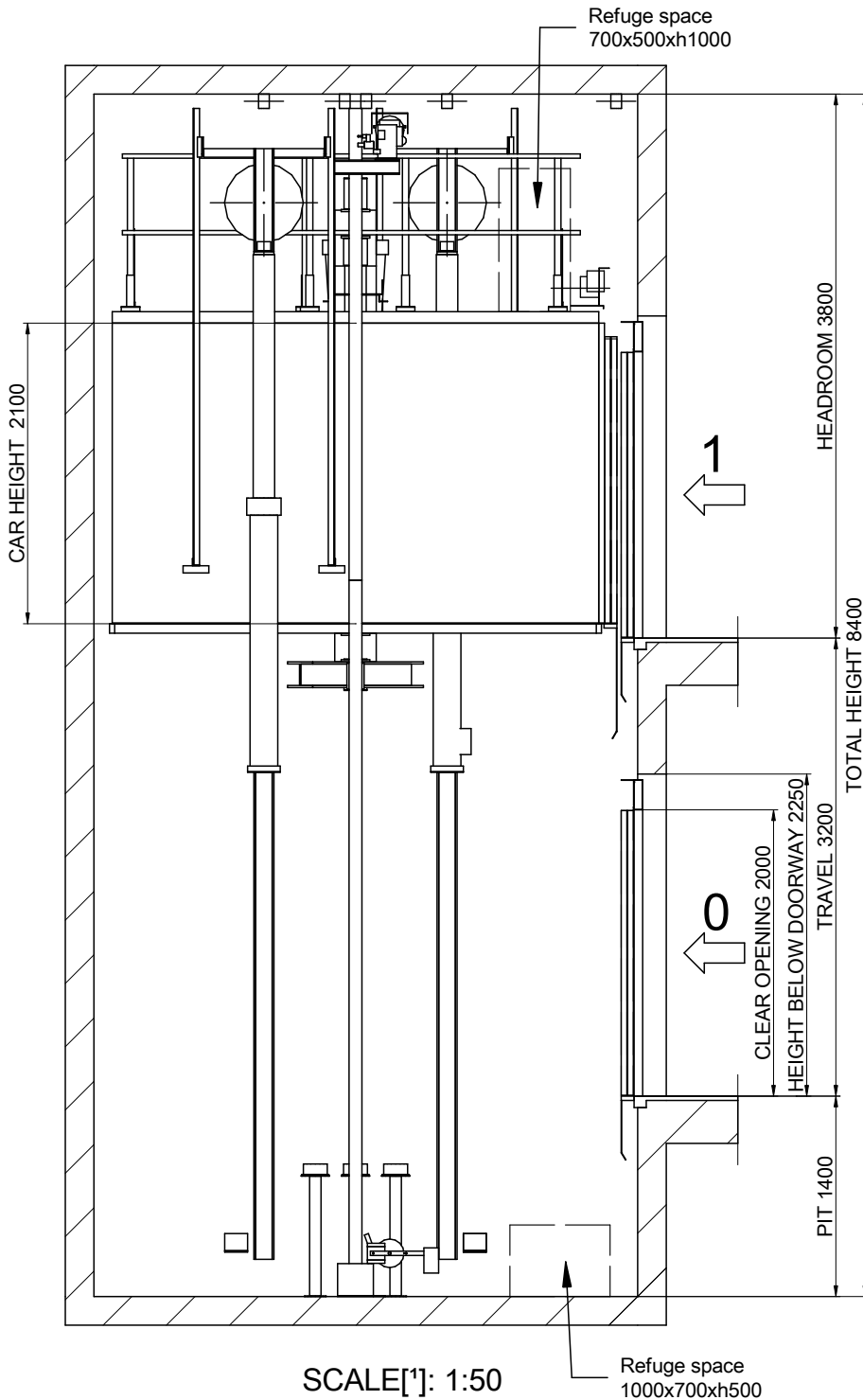

DRAWING		DATE		REV.	SHEET	[!] Unbounded dimensions in drawings are indicative and not binding.
		2017	00	3/8		
MP		DATE		REV.	SHEET	REFERENCE:
MODEL LIFT:		2017		00	3/8	MPH_MONTACARGAS_5000_EN
CAPACITY: [N° PERSONS]		MP H				CLIENT:
66						WORK SITUATION:
NOMINAL LOAD: [kg]						
5000						
SPEED: [m/s]						
0.5						
FREQUENCY: [Hz]						
50						
TENSION: [V]						
380V [Three-phase]						MP LIFTS

Flat and levelled floor, protected against water leaking.  
 [EN81-20:2014 5.2.1.9]  
 Foresee pit access device  
 [EN81-20:2014 5.2.2.4]  
 Stop device  
 [EN81-20:2014 5.2.1.5.1. a]  
 Inspection control station.  
 [EN81-20:2014 5.2.1.5.1. b]  
 Power supply  
 [EN81-20:2014 5.2.1.5.1. c]  
 Light switch  
 commuted with the cabinet.  
 [EN81-20:2014 5.2.1.5.1. d]

MAX DISTANCE  
 BETWEEN BRACKETS  
 = 1500 mm

# 04-BEAM AND LIFTING HOOKS

POSITION OF REMOVABLE LIFTING HOOKS ABLE TO SUPPORT  
3500 kg EACH ONE SUPPLIED BY CONSTRUCTOR  
(RECOMMENDED POSITION LOADHOOKS)

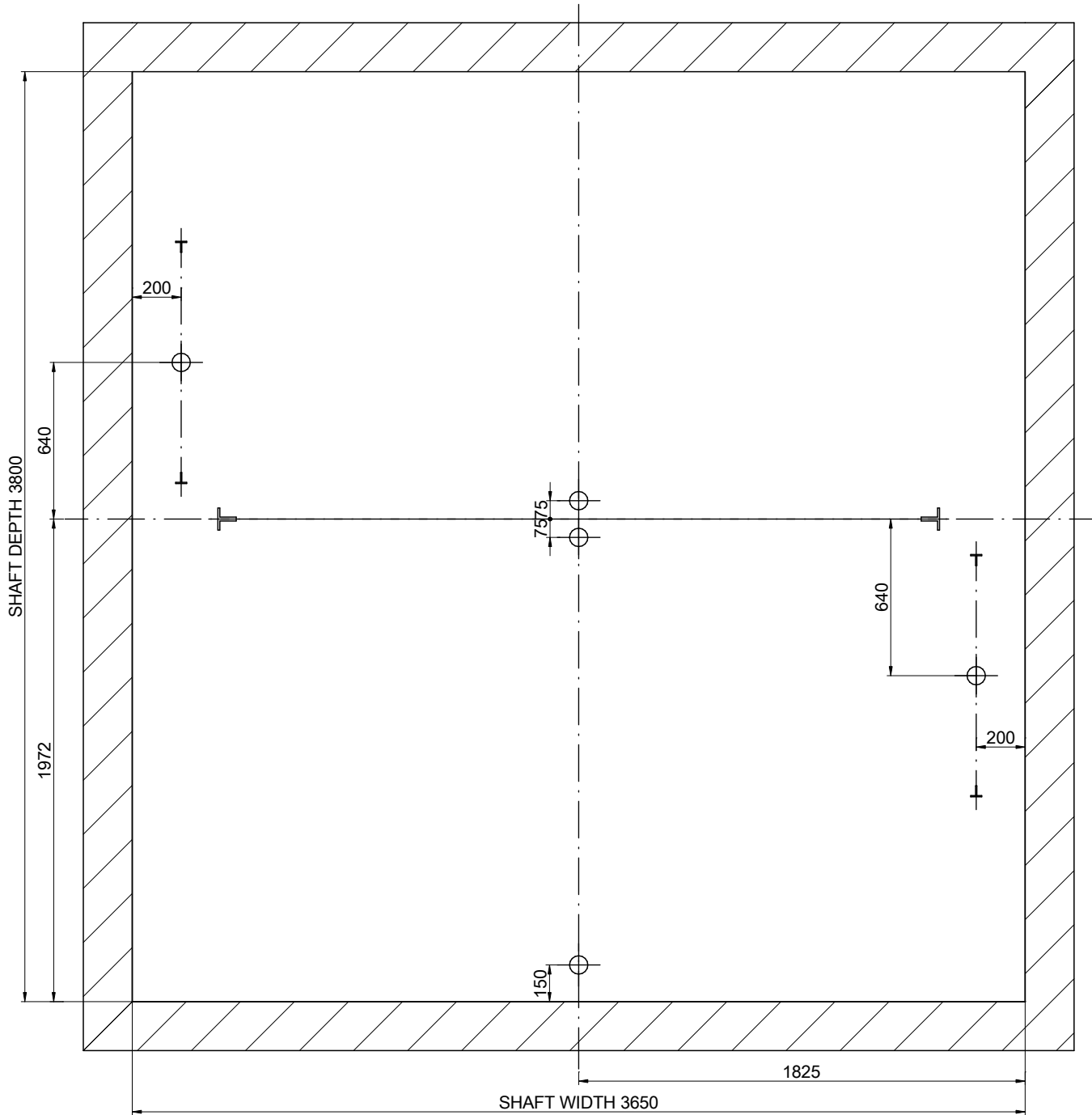

SCALE[\*]: 1:25

DRAWING	DATE	REV.	SHEET	[*] Unbounded dimensions in drawings are indicative and not binding.	
MP	2017	00	4/8	REFERENCE: MPH_MONTACARGAS_5000_EN	
MODEL LIFT:				CLIENT:	WORK SITUATION:
MP H					
CAPACITY: [N° PERSONS]			66	<h2>MP LIFTS</h2>	
NOMINAL LOAD: [kg]			5000		
SPEED: [m/s]			0.5		
FREQUENCY: [Hz]			50		
TENSION: [V]			380V [Three-phase]		

# 04B-MACHINE ROOM

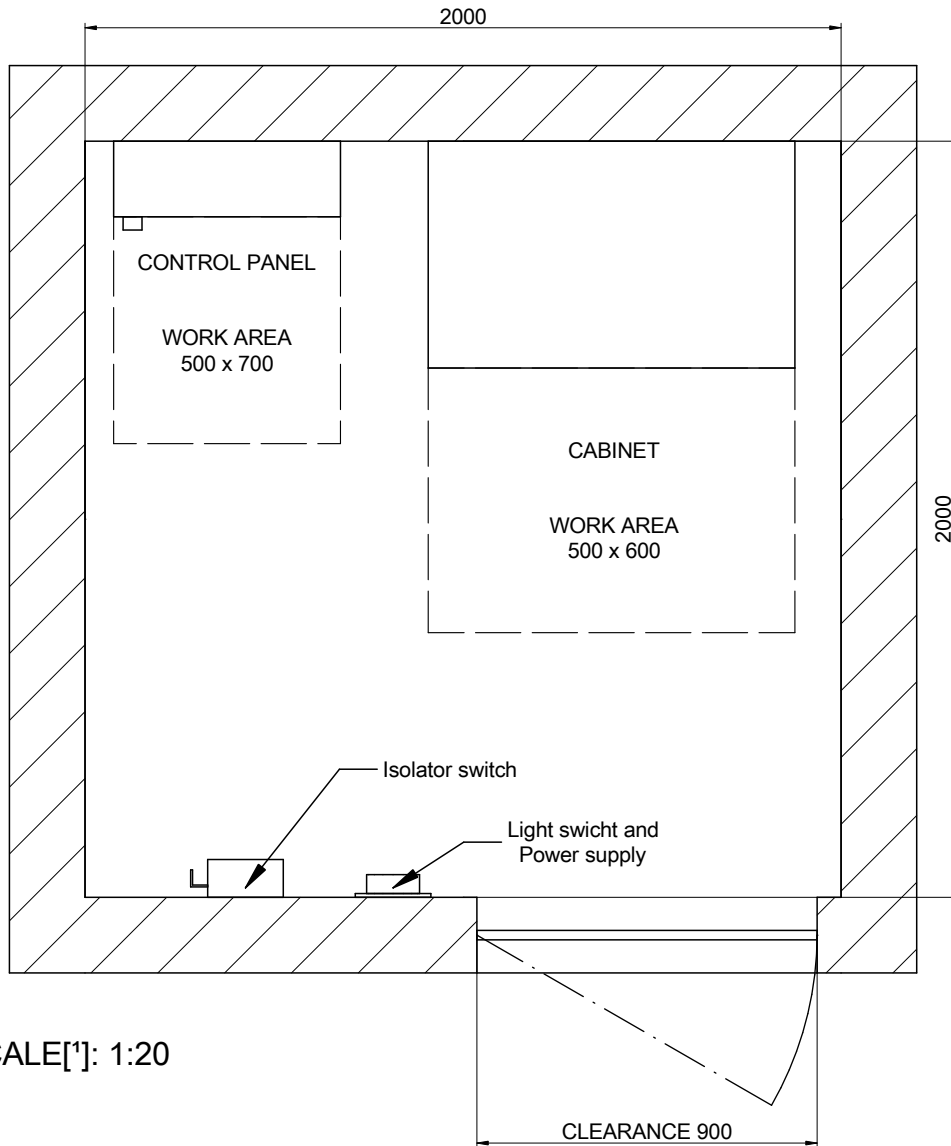

SCALE[\*]: 1:20

Minimum machine room height: 2100 mm.  
 [EN 81-20:2014 5.2.6.3.2.1]  
 Minimum clearance door: 600x2000 mm.  
 [EN 81-20:2014 5.2.3.2 a)]

Machine room location:  
 Machine room located in floor level:  
 [3] Distance controller/shaft:  
 Cylinder oil entrance location: 0

DRAWING	DATE	REV.	SHEET	[*] Unbounded dimensions in drawings are indicative and not binding.	
MP	2017	00	5/8	REFERENCE: MPH_MONTACARGAS_5000_EN	
MODEL LIFT:				CLIENT:	WORK SITUATION:
MP H					
CAPACITY: [N° PERSONS]		66		<b>MP LIFTS</b>	
NOMINAL LOAD: [kg]		5000			
SPEED: [m/s]		0.5			
FREQUENCY: [Hz]		50			
TENSION: [V]		380V [Three-phase]			

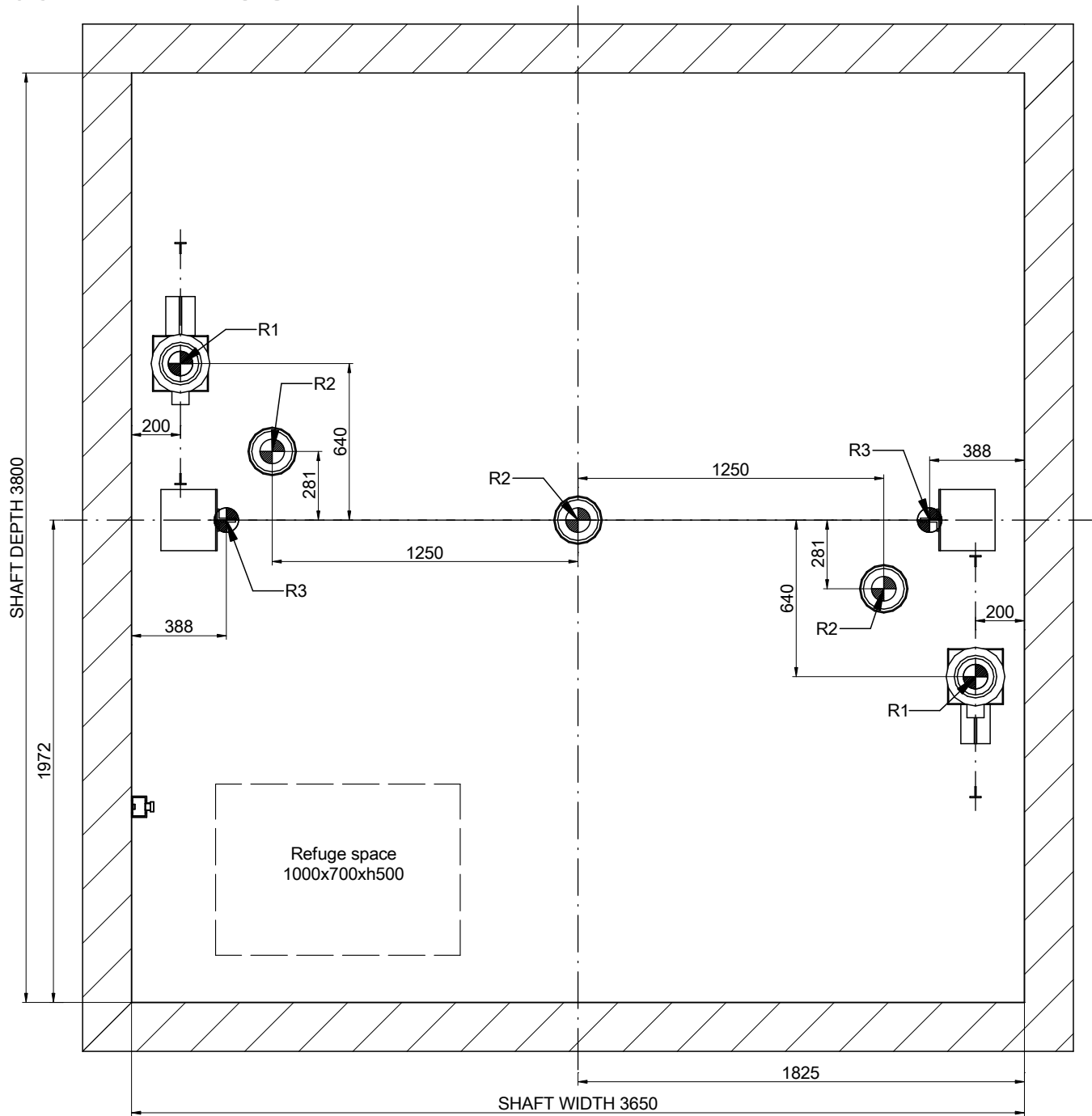

# 05-PIT LAYOUT

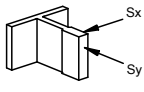

SCALE[1]: 1:25

REACTIONS [N] [max.]			
R1	125000	R2	111200
R3	64000		
Sx	7911	Sy	13270



DRAWING	DATE	REV.	SHEET	[*] Unbounded dimensions in drawings are indicative and not binding.	
MP	2017	00	6/8	REFERENCE: MPH_MONTACARGAS_5000_EN	
MODEL LIFT:				CLIENT:	
MP H				WORK SITUATION:	
CAPACITY: [N° PERSONS]		66			
NOMINAL LOAD: [kg]		5000			
SPEED: [m/s]		0.5			
FREQUENCY: [Hz]		50			
TENSION: [V]		380V [Three-phase]			

MP LIFTS

# 06-DOOR HOLE DETAIL

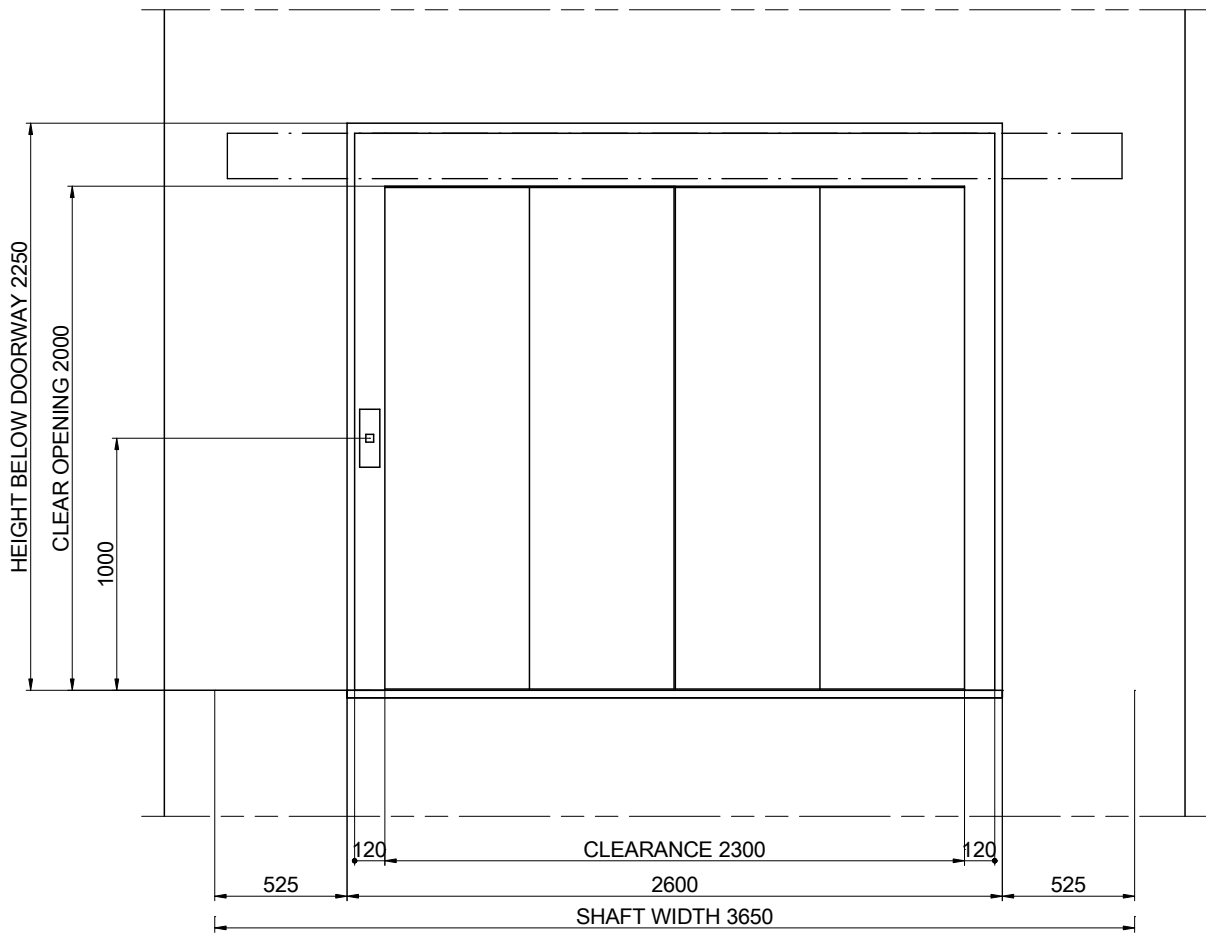

SCALE[\*]: 1:30

[2] Uprights recess

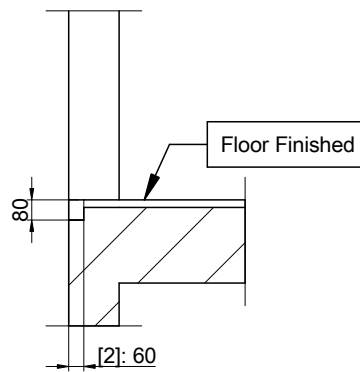

SCALE[\*]: 1:30

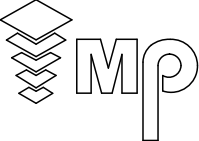
DRAWING	DATE	REV.	SHEET	[*] Unbounded dimensions in drawings are indicative and not binding.	
MP	2017	00	7/8	REFERENCE: MPH_MONTACARGAS_5000_EN	
MODEL LIFT:				CLIENT:	<p><b>MP LIFTS</b></p>
<b>MP H</b>				WORK SITUATION:	
CAPACITY: [N° PERSONS]		66			
NOMINAL LOAD: [kg]		5000			
SPEED: [m/s]		0.5			
FREQUENCY: [Hz]		50			
TENSION: [V]		380V [Three-phase]			

# 07-HEADROOM

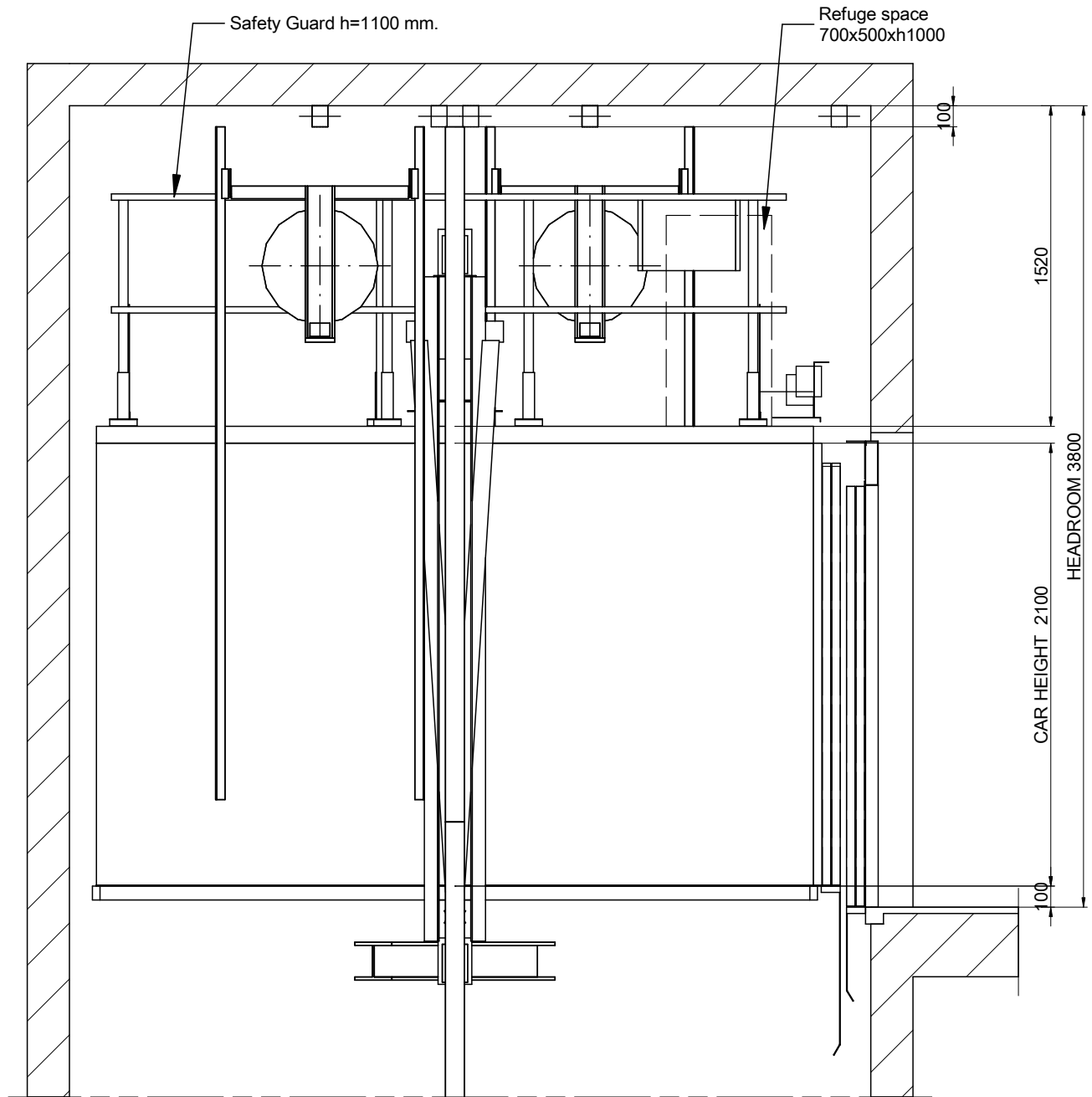

SCALE[\*]: 1:30

DRAWING	DATE	REV.	SHEET	[*] Unbounded dimensions in drawings are indicative and not binding. REFERENCE: MPH_MONTACARGAS_5000_EN	
MP	2017	00	8/8		
MODEL LIFT:				CLIENT:	WORK SITUATION:
MP H					
CAPACITY: [N° PERSONS]		66		<b>MP LIFTS</b>	
NOMINAL LOAD: [kg]		5000			
SPEED: [m/s]		0.5			
FREQUENCY: [Hz]		50			
TENSION: [V]		380V [Three-phase]			