

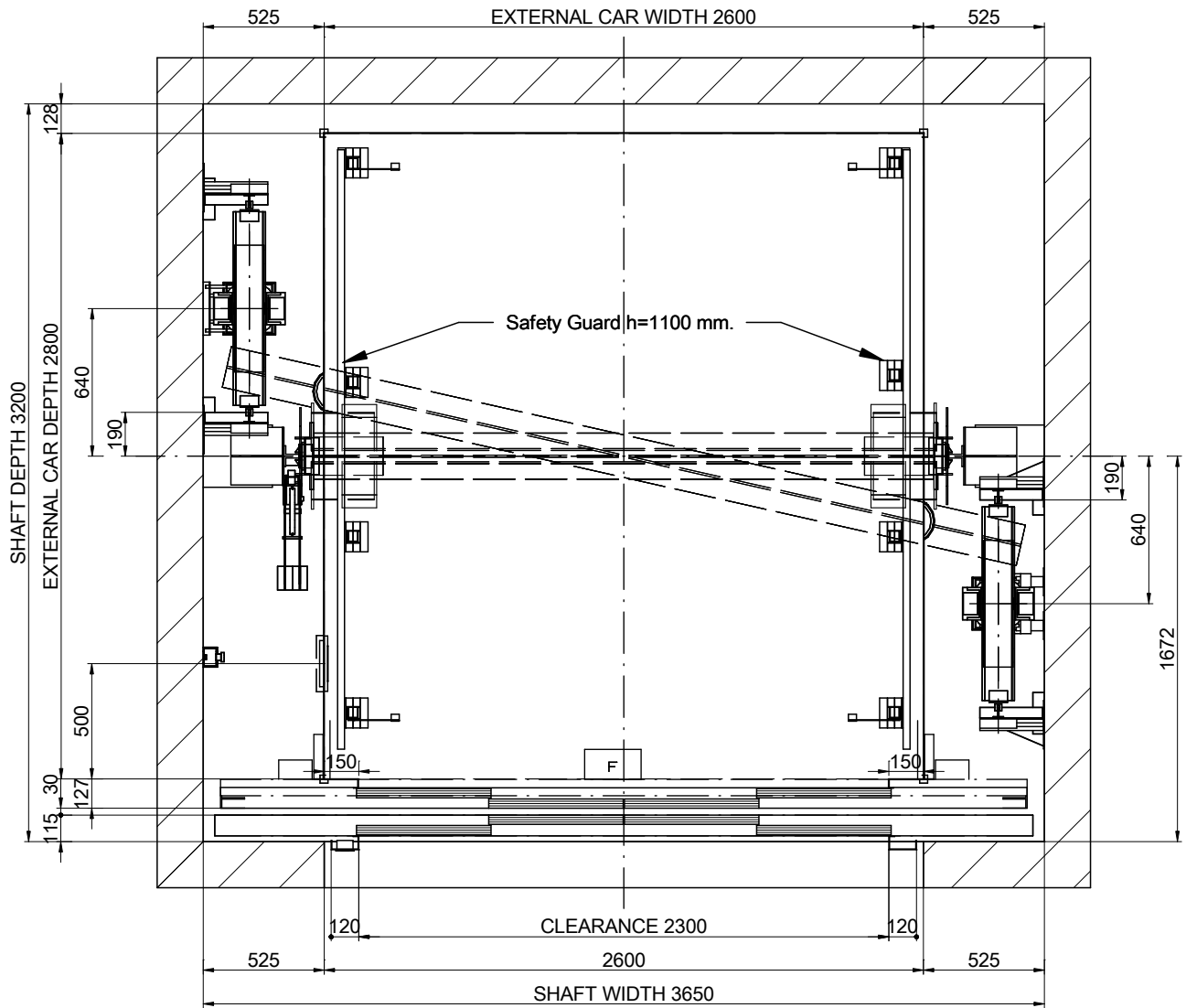

01-PLAN VIEW



DRAWING	DATE	REV.	SHEET	[*] Unbounded dimensions in drawings are indicative and not binding.	
MP	2017	00	1/8		
MODEL LIFT:				REFERENCE:	CLIENT: WORK SITUATION:
MP H				MPH_MONTACARGAS_4000_EN	
CAPACITY: [N° PERSONS]		53		<h2>MP LIFTS</h2>	
NOMINAL LOAD: [kg]		4000			
SPEED: [m/s]		0.5			
FREQUENCY: [Hz]		50			
TENSION: [V]		380V [Three-phase]			

01B-PLAN VIEW

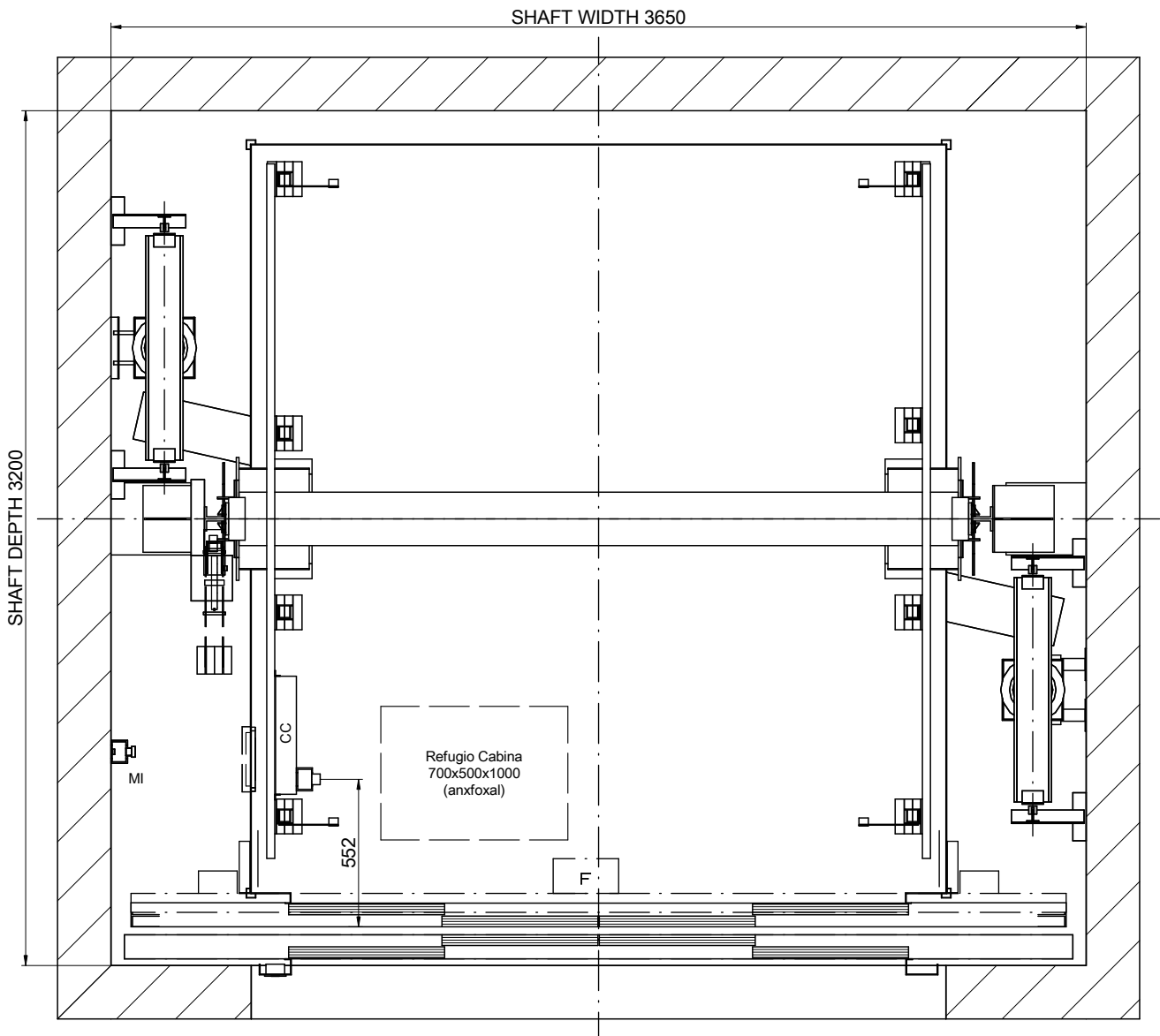

SCALE[*]: 1:25

NOMENCLATURE

CC: Car ceiling connection box
MI: Inspection control station

DRAWING	DATE	REV.	SHEET	[*] Unbounded dimensions in drawings are indicative and not binding.	
MP	2017	00	2/8	REFERENCE: MPH_MONTACARGAS_4000_EN	
MODEL LIFT:				CLIENT:	WORK SITUATION:
MP H					
CAPACITY: [N° PERSONS]			53	<h1>MP LIFTS</h1>	
NOMINAL LOAD: [kg]			4000		
SPEED: [m/s]			0.5		
FREQUENCY: [Hz]			50		
TENSION: [V]			380V [Three-phase]		

02-SIDE VERTICAL SECTION

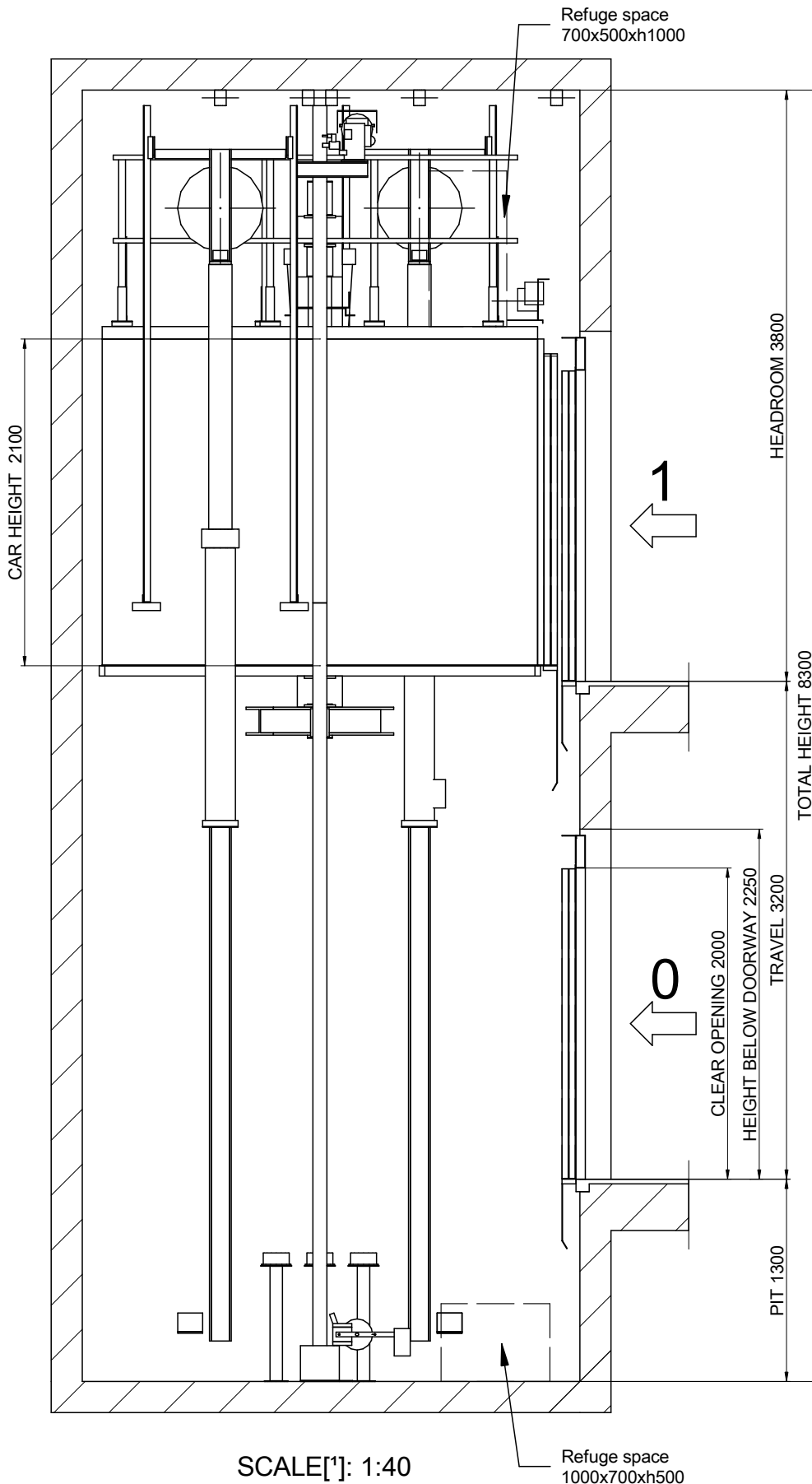

DRAWING		DATE		REV.	SHEET	[*] Unbounded dimensions in drawings are indicative and not binding.
		2017	00	3/8		
MP		2017		00	3/8	REFERENCE: MPH_MONTACARGAS_4000_EN
MODEL LIFT:		MP H		53		CLIENT: WORK SITUATION:
CAPACITY: [N° PERSONS]		53		4000		
NOMINAL LOAD: [kg]		4000		0.5		
SPEED: [m/s]		0.5		50		
FREQUENCY: [Hz]		50		380V [Three-phase]		
TENSION: [V]		380V [Three-phase]				

Flat and levelled floor, protected against water leaking.
[EN81-20:2014 5.2.1.9]
Foresee pit access device
[EN81-20:2014 5.2.2.4]
Stop device
[EN81-20:2014 5.2.1.5.1. a]
Inspection control station.
[EN81-20:2014 5.2.1.5.1. b]
Power supply
[EN81-20:2014 5.2.1.5.1. c]
Light switch
commuted with the cabinet.
[EN81-20:2014 5.2.1.5.1. d]

MAX DISTANCE
BETWEEN BRACKETS
= 1500 mm



MP LIFTS

04-BEAM AND LIFTING HOOKS

POSITION OF REMOVABLE LIFTING HOOKS ABLE TO SUPPORT
3500 kg EACH ONE SUPPLIED BY CONSTRUCTOR
(RECOMMENDED POSITION LOADHOOKS)

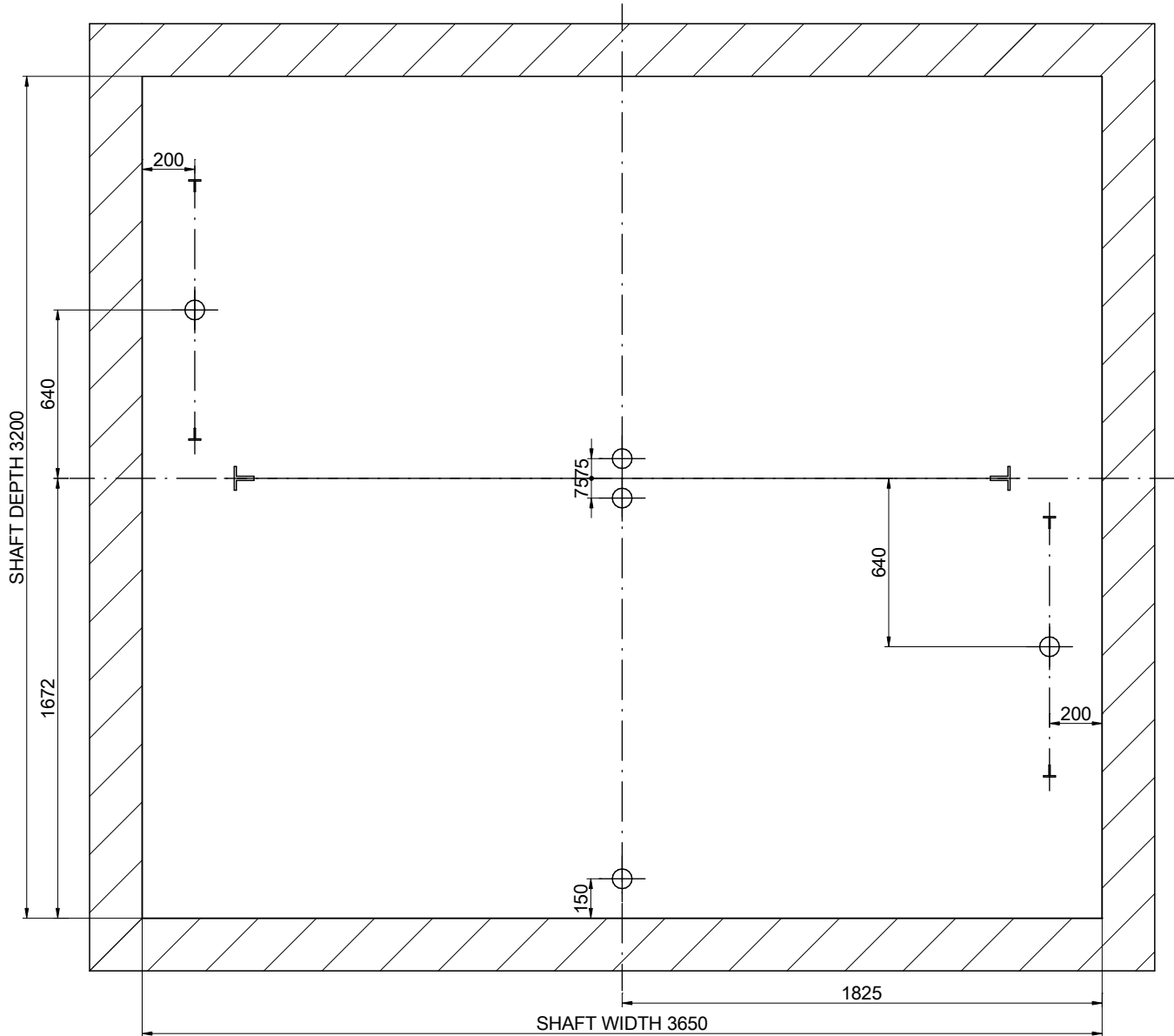

SCALE[*]: 1:25

DRAWING	DATE	REV.	SHEET	[*] Unbounded dimensions in drawings are indicative and not binding.	
MP	2017	00	4/8	REFERENCE: MPH_MONTACARGAS_4000_EN	
MODEL LIFT:				CLIENT:	WORK SITUATION:
MP H					
CAPACITY: [N° PERSONS]			53	<h2>MP LIFTS</h2>	
NOMINAL LOAD: [kg]			4000		
SPEED: [m/s]			0.5		
FREQUENCY: [Hz]			50		
TENSION: [V]			380V [Three-phase]		

04B-MACHINE ROOM

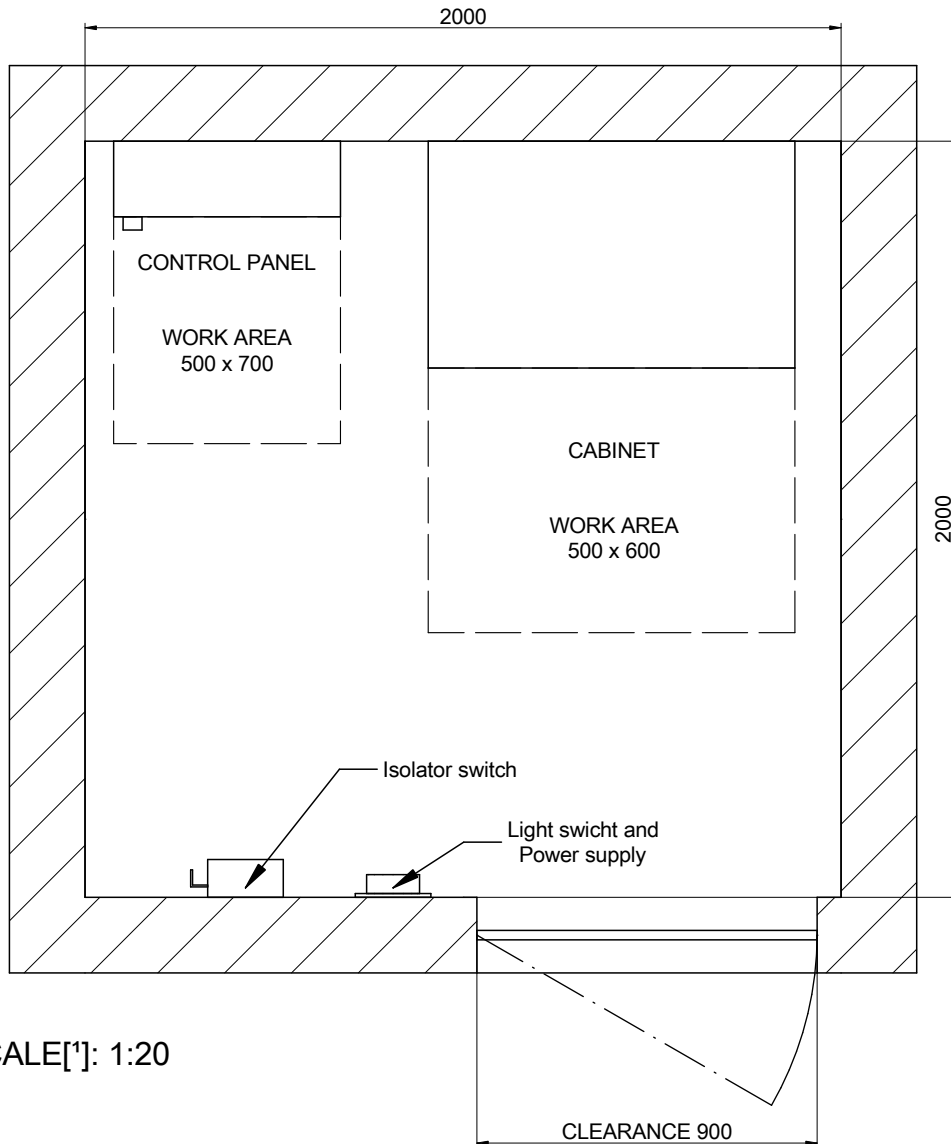

SCALE[*]: 1:20

Minimum machine room height: 2100 mm.
 [EN 81-20:2014 5.2.6.3.2.1]
 Minimum clearance door: 600x2000 mm.
 [EN 81-20:2014 5.2.3.2 a)]

Machine room location:
 Machine room located in floor level:
 [3] Distance controller/shaft:
 Cylinder oil entrance location: 0

DRAWING	DATE	REV.	SHEET	[*] Unbounded dimensions in drawings are indicative and not binding.	
MP	2017	00	5/8	REFERENCE: MPH_MONTACARGAS_4000_EN	
MODEL LIFT:				CLIENT:	WORK SITUATION:
MP H					
CAPACITY: [N° PERSONS]		53		MP LIFTS	
NOMINAL LOAD: [kg]		4000			
SPEED: [m/s]		0.5			
FREQUENCY: [Hz]		50			
TENSION: [V]		380V [Three-phase]			

05-PIT LAYOUT

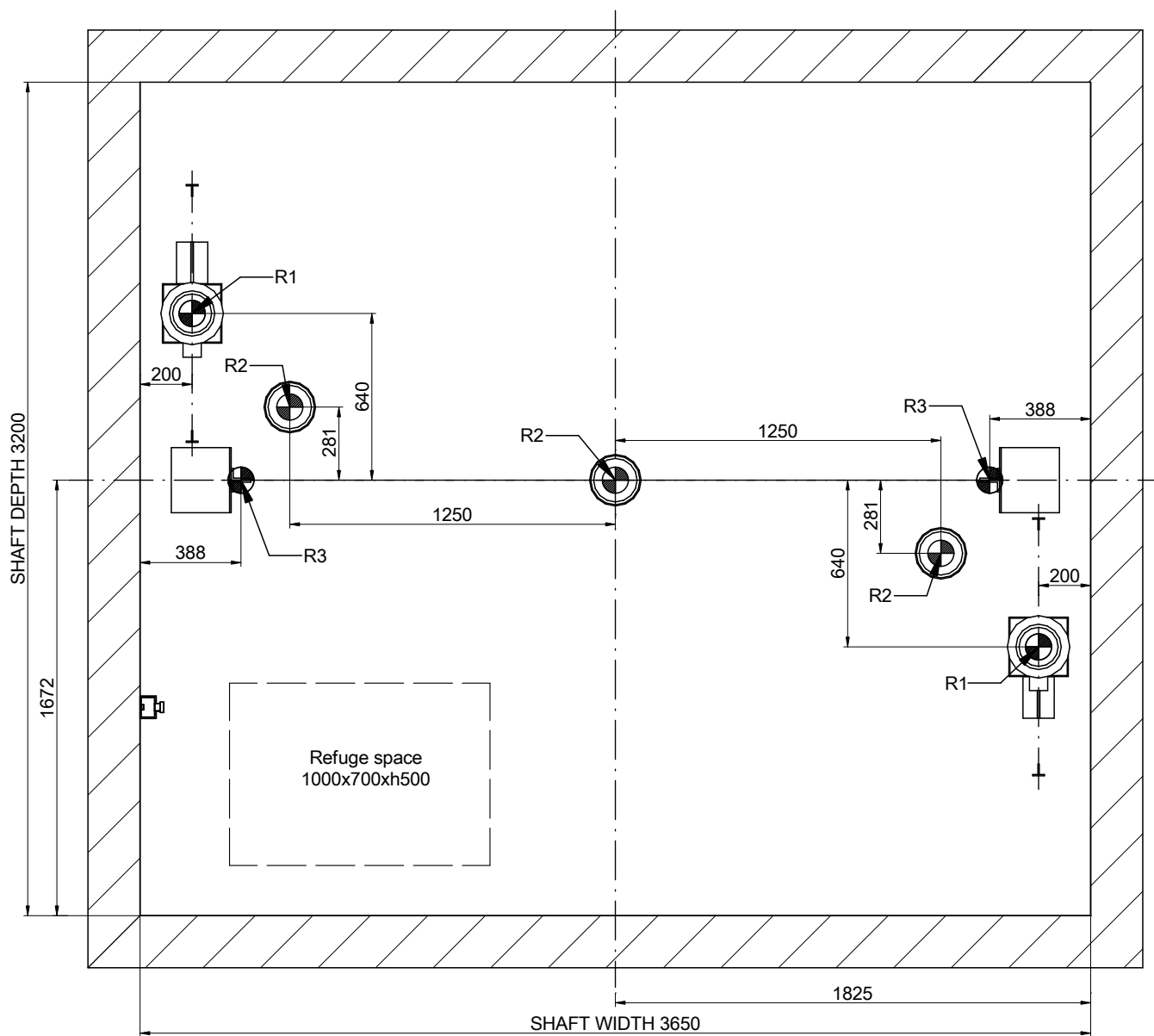

SCALE[*]: 1:25

REACTIONS [N] [max.]			
R1	101350	R2	68750
R3	96900		
Sx	6850	Sy	12740

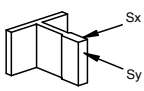

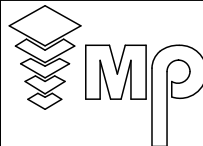
DRAWING	DATE	REV.	SHEET	[*] Unbounded dimensions in drawings are indicative and not binding.	
MP	2017	00	6/8	REFERENCE: MPH_MONTACARGAS_4000_EN	
MODEL LIFT:				CLIENT:	
MP H					
CAPACITY: [N° PERSONS]			53	WORK SITUATION:	
NOMINAL LOAD: [kg]			4000		
SPEED: [m/s]			0.5		
FREQUENCY: [Hz]			50		
TENSION: [V]			380V [Three-phase]		
				MP LIFTS	

06-DOOR HOLE DETAIL

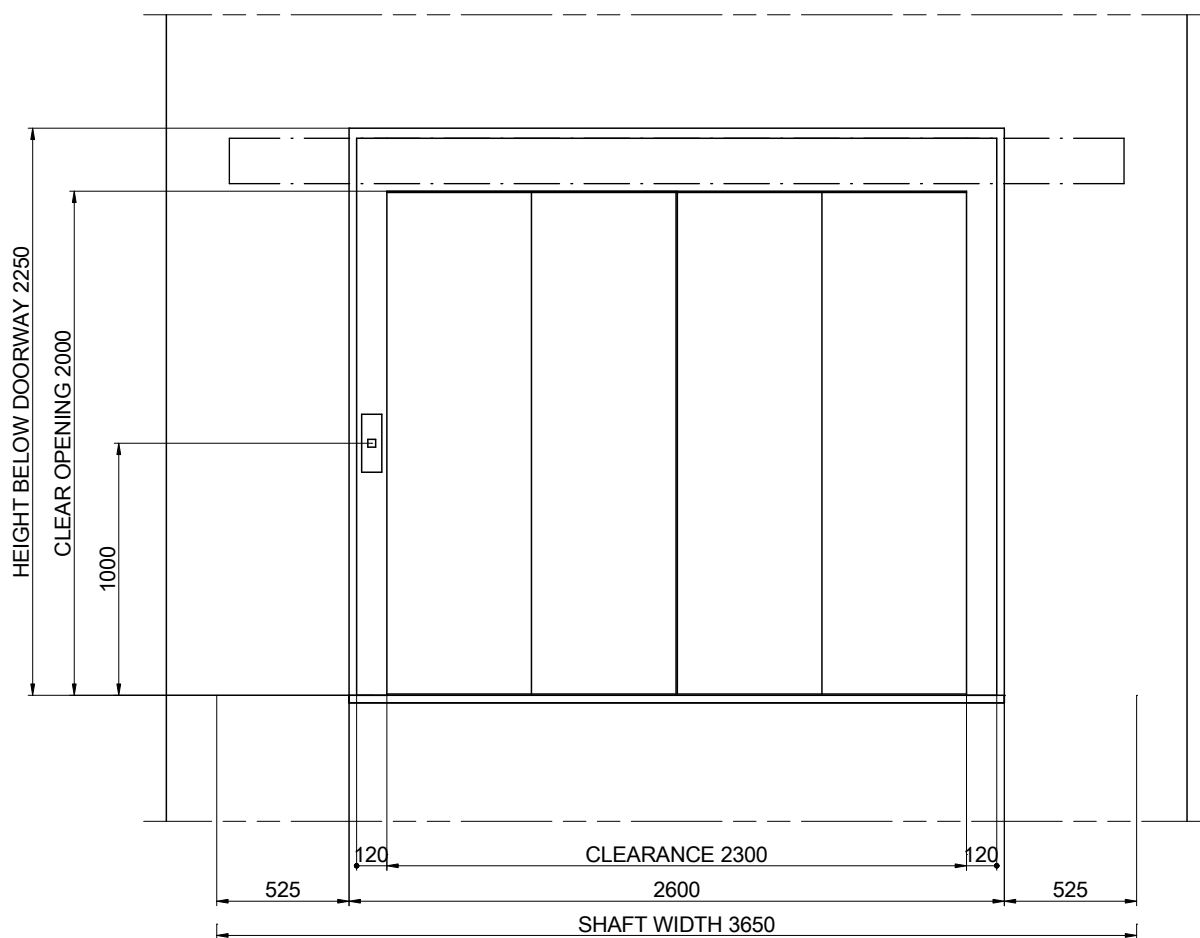

SCALE[*]: 1:30

[2] Uprights recess

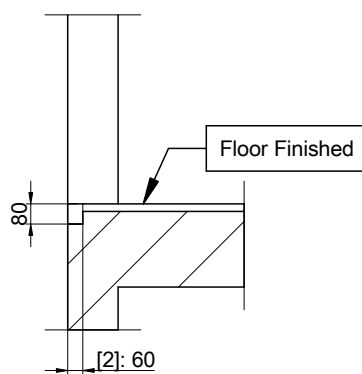

SCALE[*]: 1:30

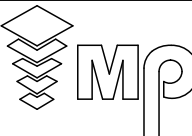
DRAWING	DATE	REV.	SHEET	[*] Unbounded dimensions in drawings are indicative and not binding. REFERENCE: MPH_MONTACARGAS_4000_EN	
MP	2017	00	7/8		
MODEL LIFT:				CLIENT:	WORK SITUATION:
MP H					
CAPACITY: [N° PERSONS]		53		MP LIFTS	
NOMINAL LOAD: [kg]		4000			
SPEED: [m/s]		0.5			
FREQUENCY: [Hz]		50			
TENSION: [V]		380V [Three-phase]			

07-HEADROOM

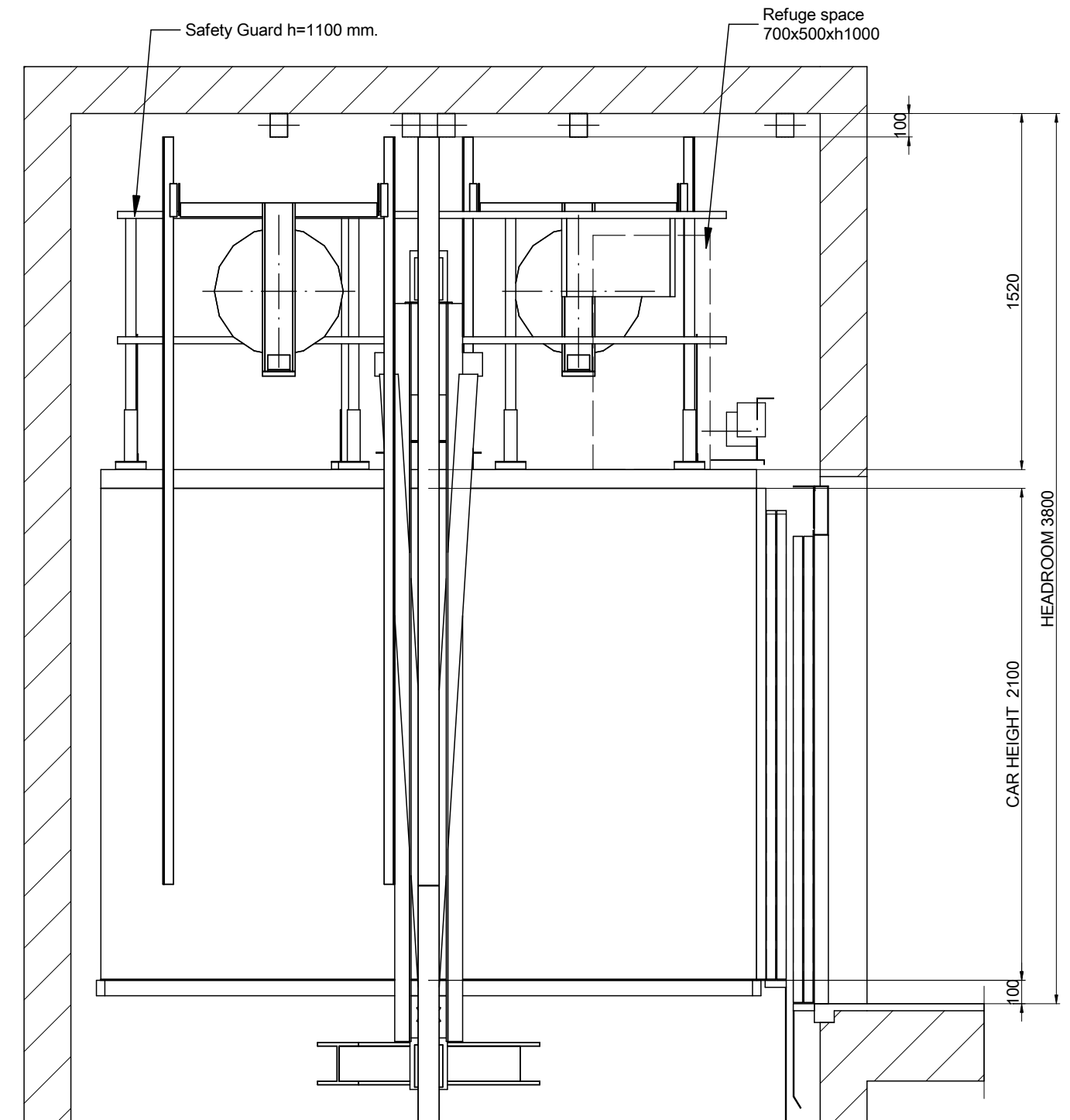

SCALE[*]: 1:25

DRAWING	DATE	REV.	SHEET	[*] Unbounded dimensions in drawings are indicative and not binding. REFERENCE: MPH_MONTACARGAS_4000_EN	
MP	2017	00	8/8		
MODEL LIFT:				CLIENT:	WORK SITUATION:
MP H					
CAPACITY: [N° PERSONS]		53		MP LIFTS	
NOMINAL LOAD: [kg]		4000			
SPEED: [m/s]		0.5			
FREQUENCY: [Hz]		50			
TENSION: [V]		380V [Three-phase]			