

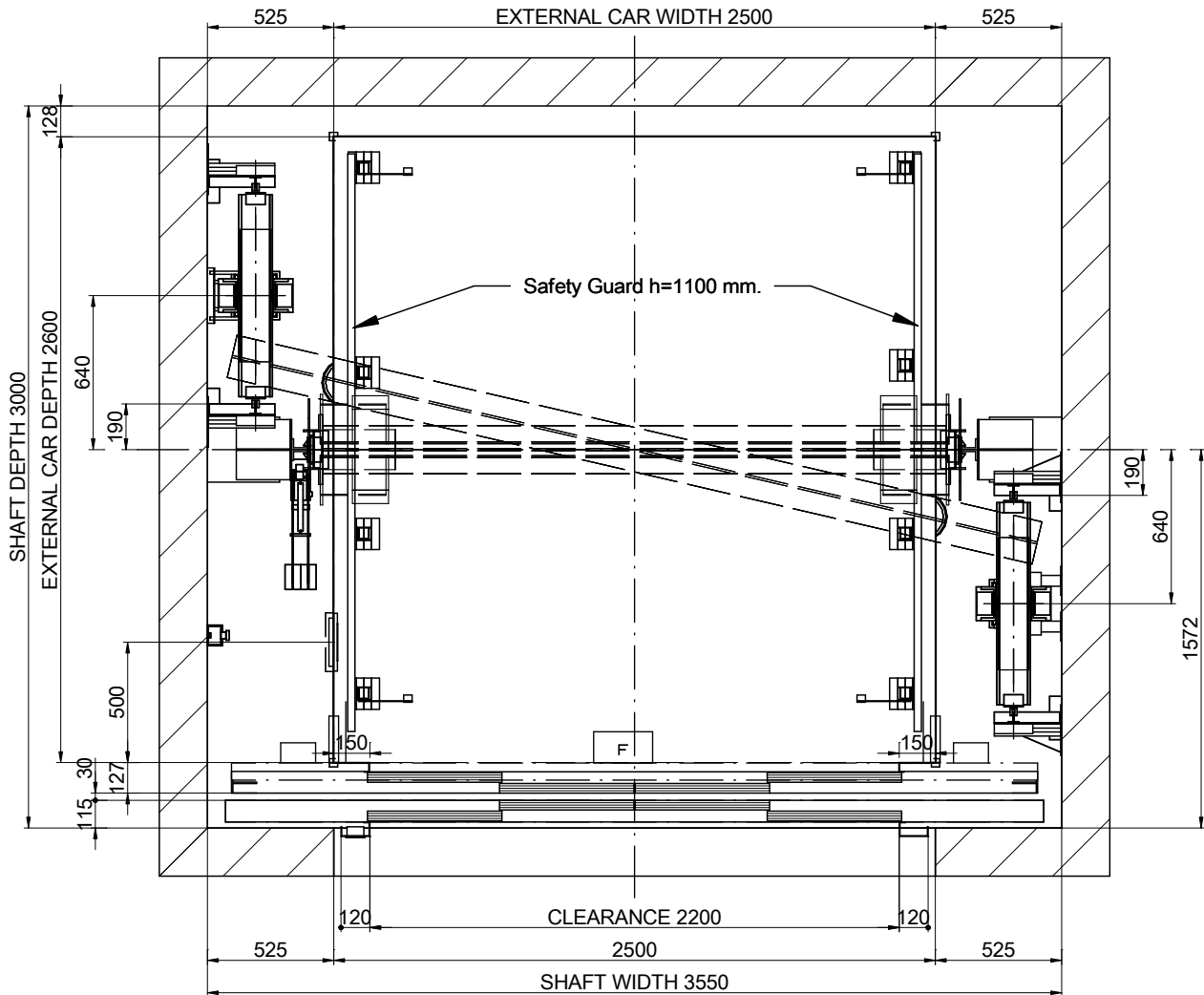

# 01-PLAN VIEW



SCALE[\*]: 1:30

DRAWING	DATE	REV.	SHEET	[*] Unbounded dimensions in drawings are indicative and not binding.	
MP	2017	00	1/8	REFERENCE: MPH_MONTACARGAS_3500_EN	
MODEL LIFT:				CLIENT:	<p><b>MP LIFTS</b></p>
<b>MP H</b>				WORK SITUATION:	
CAPACITY: [N° PERSONS]			46		
NOMINAL LOAD: [kg]			3500		
SPEED: [m/s]			0.5		
FREQUENCY: [Hz]			50		
TENSION: [V]		380V [Three-phase]			

# 01B-PLAN VIEW

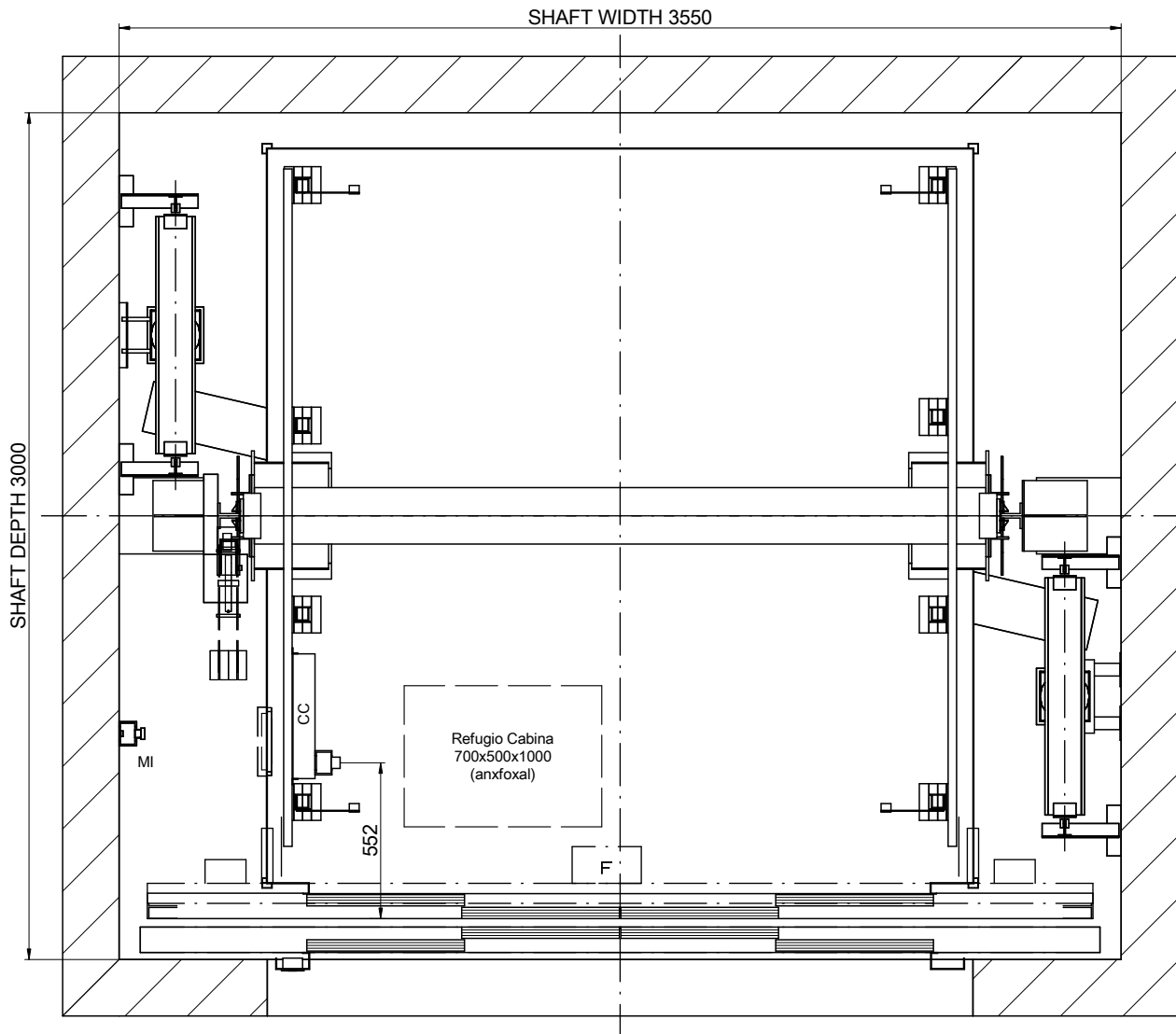

SCALE[\*]: 1:25

## NOMENCLATURE

CC: Car ceiling connection box

MI: Inspection control station

DRAWING	DATE	REV.	SHEET	[*] Unbounded dimensions in drawings are indicative and not binding.	
MP	2017	00	2/8	REFERENCE: MPH_MONTACARGAS_3500_EN	
MODEL LIFT:				CLIENT:	WORK SITUATION:
MP H					
CAPACITY: [N° PERSONS]			46	<h1>MP LIFTS</h1>	
NOMINAL LOAD: [kg]			3500		
SPEED: [m/s]			0.5		
FREQUENCY: [Hz]			50		
TENSION: [V]		380V [Three-phase]			

# 02-SIDE VERTICAL SECTION

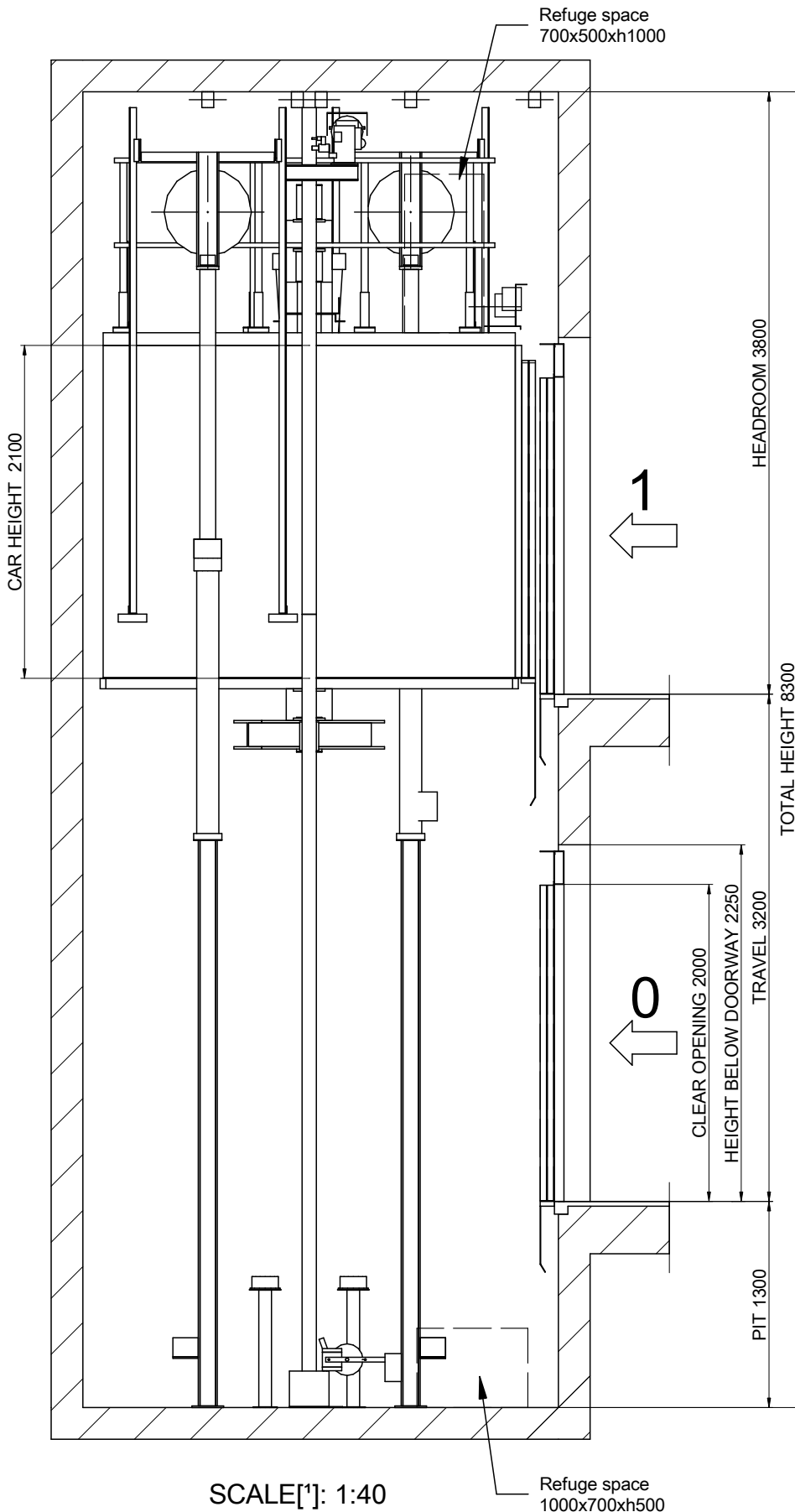

DRAWING		DATE		REV.	SHEET	[*] Unbounded dimensions in drawings are indicative and not binding.
		2017	00	3/8		
MP		MODEL LIFT:		MP H		REFERENCE: MPH_MONTACARGAS_3500_EN
CAPACITY: [N° PERSONS]		46		CLIENT:		WORK SITUATION:
NOMINAL LOAD: [kg]		3500		MPH		
SPEED: [m/s]		0.5		380V [Three-phase]		
FREQUENCY: [Hz]		50				
TENSION: [V]		380V [Three-phase]				

Flat and levelled floor, protected against water leaking.  
[EN81-20:2014 5.2.1.9]  
Foresee pit access device  
[EN81-20:2014 5.2.2.4]  
Stop device  
[EN81-20:2014 5.2.1.5.1. a]  
Inspection control station.  
[EN81-20:2014 5.2.1.5.1. b]  
Power supply  
[EN81-20:2014 5.2.1.5.1. c]  
Light switch  
commuted with the cabinet.  
[EN81-20:2014 5.2.1.5.1. d]

MAX DISTANCE  
BETWEEN BRACKETS  
= 1500 mm



MP LIFTS

# 04-BEAM AND LIFTING HOOKS

POSITION OF REMOVABLE LIFTING HOOKS ABLE TO SUPPORT  
3500 kg EACH ONE SUPPLIED BY CONSTRUCTOR  
(RECOMMENDED POSITION LOADHOOKS)

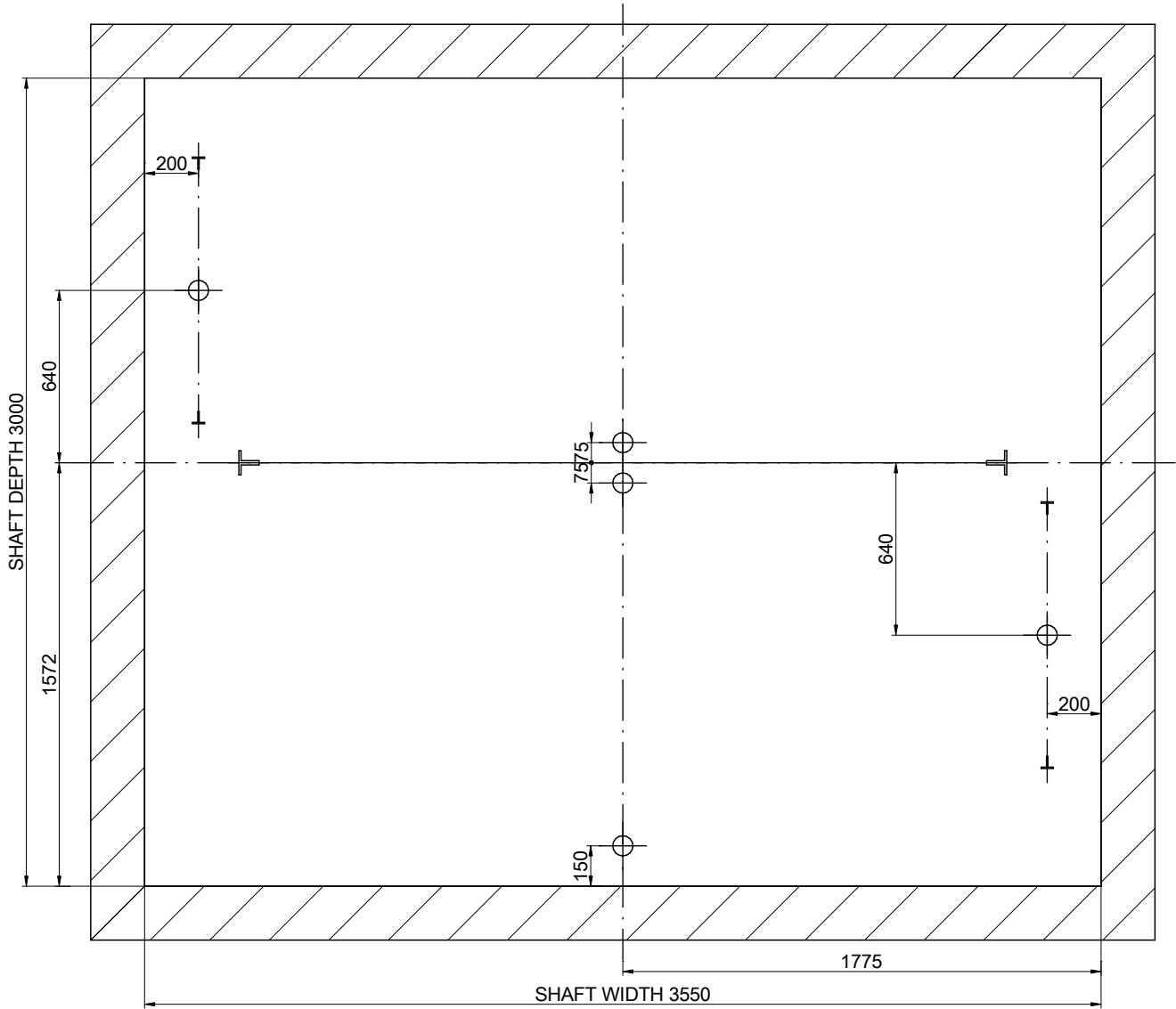

SCALE[\*]: 1:25

DRAWING	DATE	REV.	SHEET	[*] Unbounded dimensions in drawings are indicative and not binding.	
MP	2017	00	4/8	REFERENCE: MPH_MONTACARGAS_3500_EN	
MODEL LIFT:				CLIENT: WORK SITUATION:	<p style="text-align: center; font-size: 2em; font-weight: bold;">MP LIFTS</p>
MP H					
CAPACITY: [N° PERSONS]		46			
NOMINAL LOAD: [kg]		3500			
SPEED: [m/s]		0.5			
FREQUENCY: [Hz]		50			
TENSION: [V]		380V [Three-phase]			

# 04B-MACHINE ROOM

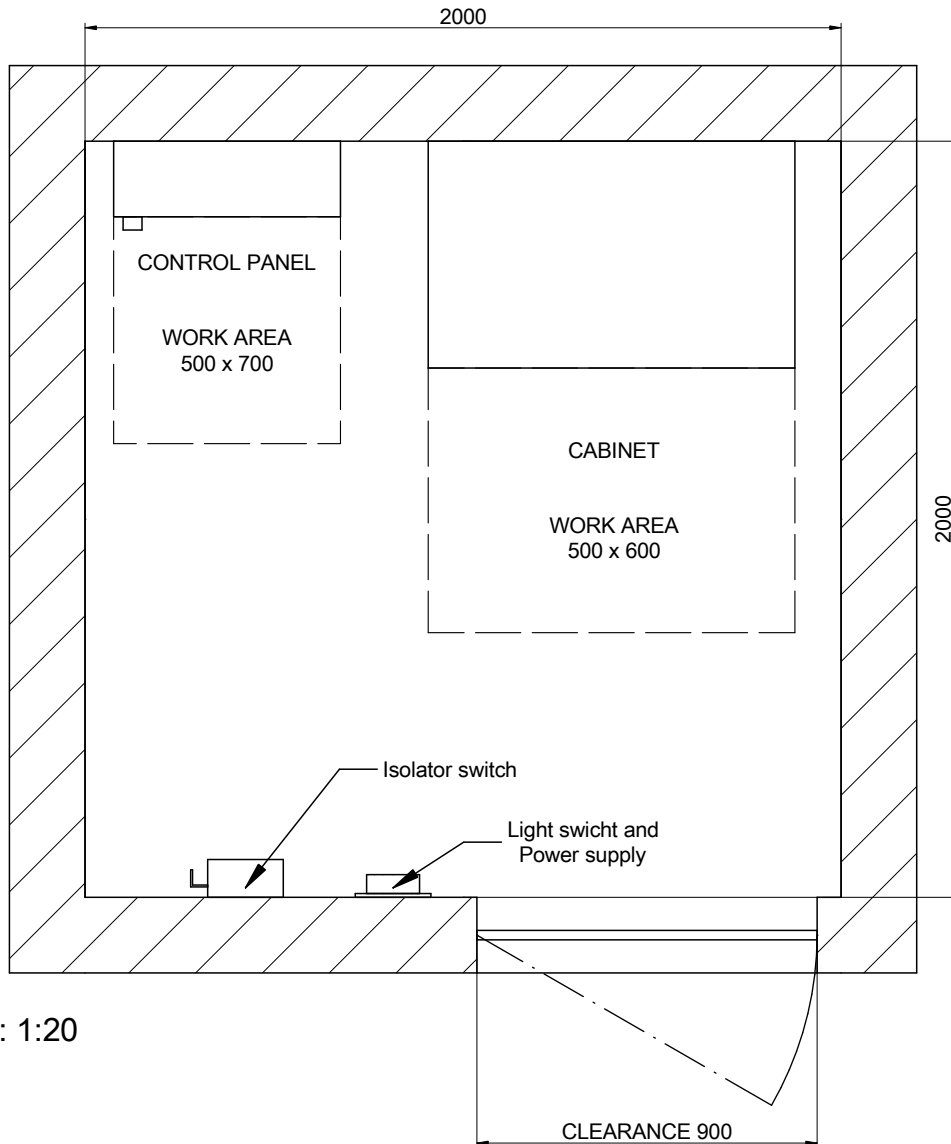

SCALE[\*]: 1:20

Minimum machine room height: 2100 mm.  
 [EN 81-20:2014 5.2.6.3.2.1]  
 Minimum clearance door: 600x2000 mm.  
 [EN 81-20:2014 5.2.3.2 a)]

Machine room location:  
 Machine room located in floor level:  
 [3] Distance controller/shaft:  
 Cylinder oil entrance location: 0

DRAWING	DATE	REV.	SHEET	[*] Unbounded dimensions in drawings are indicative and not binding.	
MP	2017	00	5/8	REFERENCE: MPH_MONTACARGAS_3500_EN	
MODEL LIFT:				CLIENT:	<h2>MP LIFTS</h2>
<b>MP H</b>				WORK SITUATION:	
CAPACITY: [N° PERSONS]			46		
NOMINAL LOAD: [kg]			3500		
SPEED: [m/s]			0.5		
FREQUENCY: [Hz]			50		
TENSION: [V]		380V [Three-phase]			

# 05-PIT LAYOUT

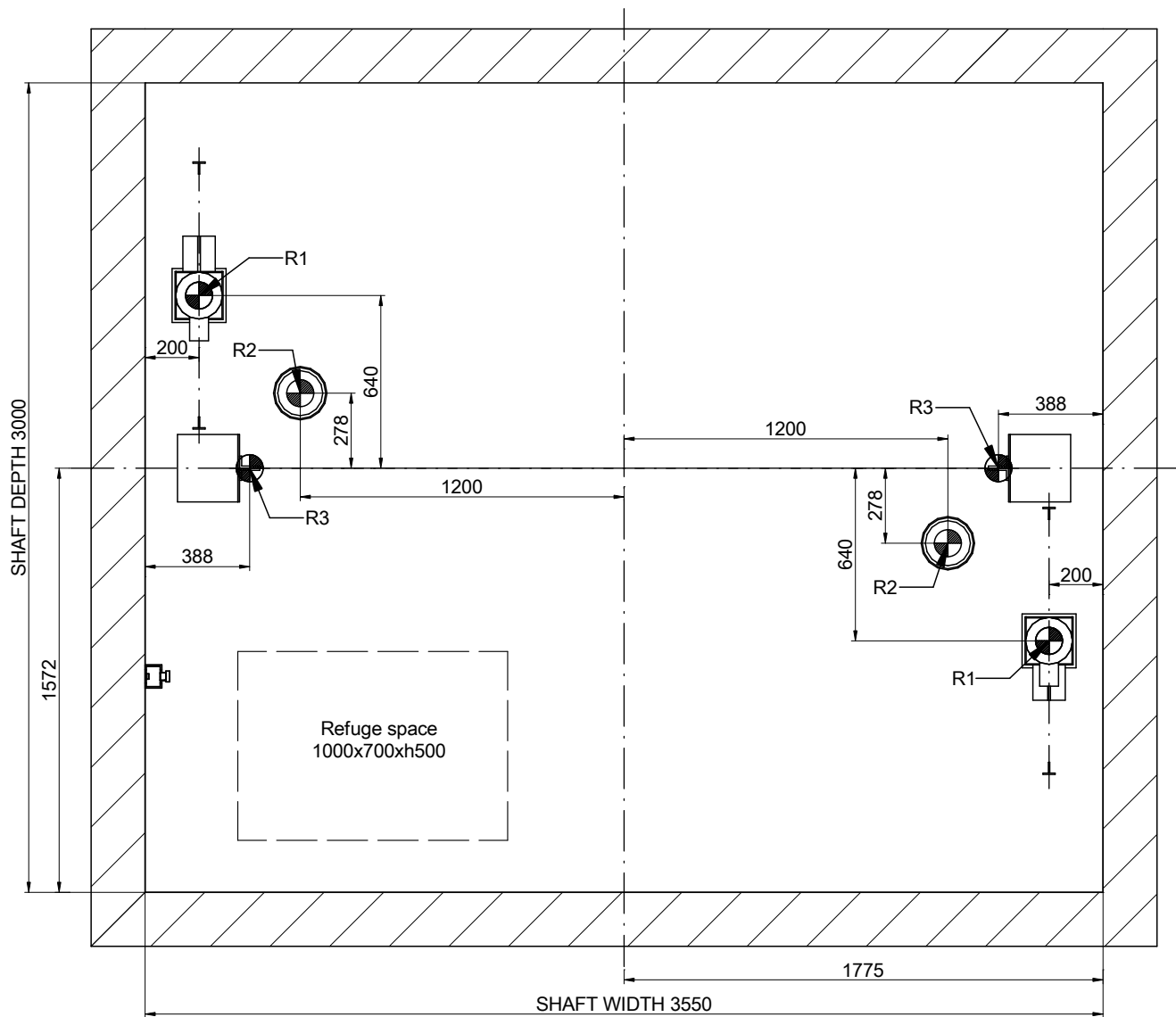

SCALE[\*]: 1:25

REACTIONS [N] [max.]					
R1	86050	R2	108800		
R3	84800				
Sx	7550	Sy	9725		

DRAWING	DATE	REV.	SHEET	[*] Unbounded dimensions in drawings are indicative and not binding.		
MP	2017	00	6/8	REFERENCE: MPH_MONTACARGAS_3500_EN		
MODEL LIFT:				CLIENT:		
MP H				WORK SITUATION:		
CAPACITY: [N° PERSONS]			46			
NOMINAL LOAD: [kg]			3500			
SPEED: [m/s]			0.5			
FREQUENCY: [Hz]			50			
TENSION: [V]			380V [Three-phase]	<b>MP LIFTS</b>		

# 06-DOOR HOLE DETAIL

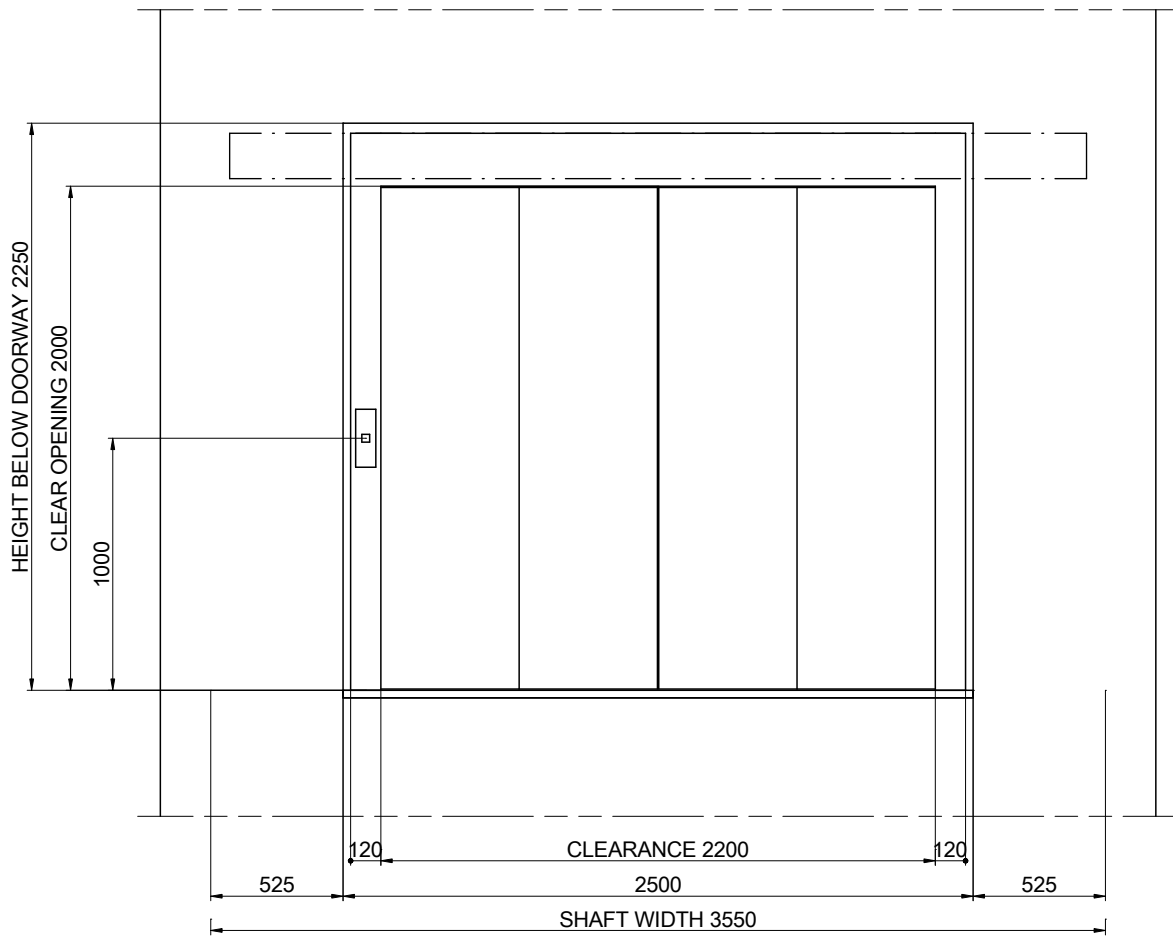

SCALE[\*]: 1:30

[2] Uprights recess

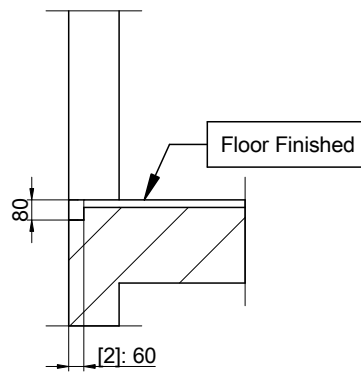

SCALE[\*]: 1:30

DRAWING	DATE	REV.	SHEET	[*] Unbounded dimensions in drawings are indicative and not binding. REFERENCE: MPH_MONTACARGAS_3500_EN	
MP	2017	00	7/8		
MODEL LIFT:				CLIENT:	WORK SITUATION:
MP H					
CAPACITY: [N° PERSONS]		46		<b>MP LIFTS</b>	
NOMINAL LOAD: [kg]		3500			
SPEED: [m/s]		0.5			
FREQUENCY: [Hz]		50			
TENSION: [V]		380V [Three-phase]			

# 07-HEADROOM

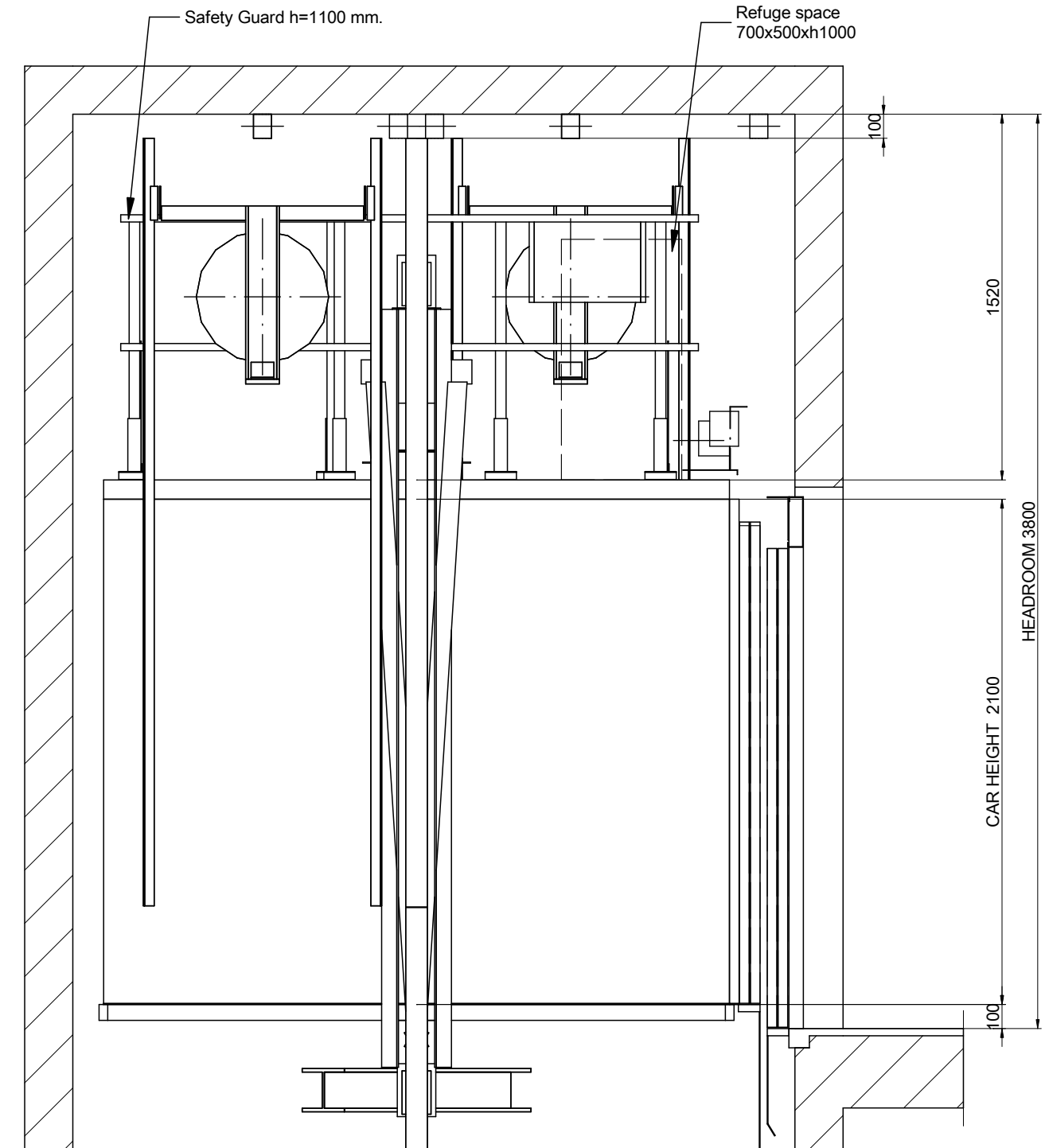

SCALE[\*]: 1:25

DRAWING	DATE	REV.	SHEET	[*] Unbounded dimensions in drawings are indicative and not binding.	
MP	2017	00	8/8		
MODEL LIFT:				CLIENT: WORK SITUATION:	<p style="text-align: center; font-size: 24px; font-weight: bold;">MP LIFTS</p>
MP H					
CAPACITY: [N° PERSONS]		46			
NOMINAL LOAD: [kg]		3500			
SPEED: [m/s]		0.5			
FREQUENCY: [Hz]		50			
TENSION: [V]		380V [Three-phase]			