

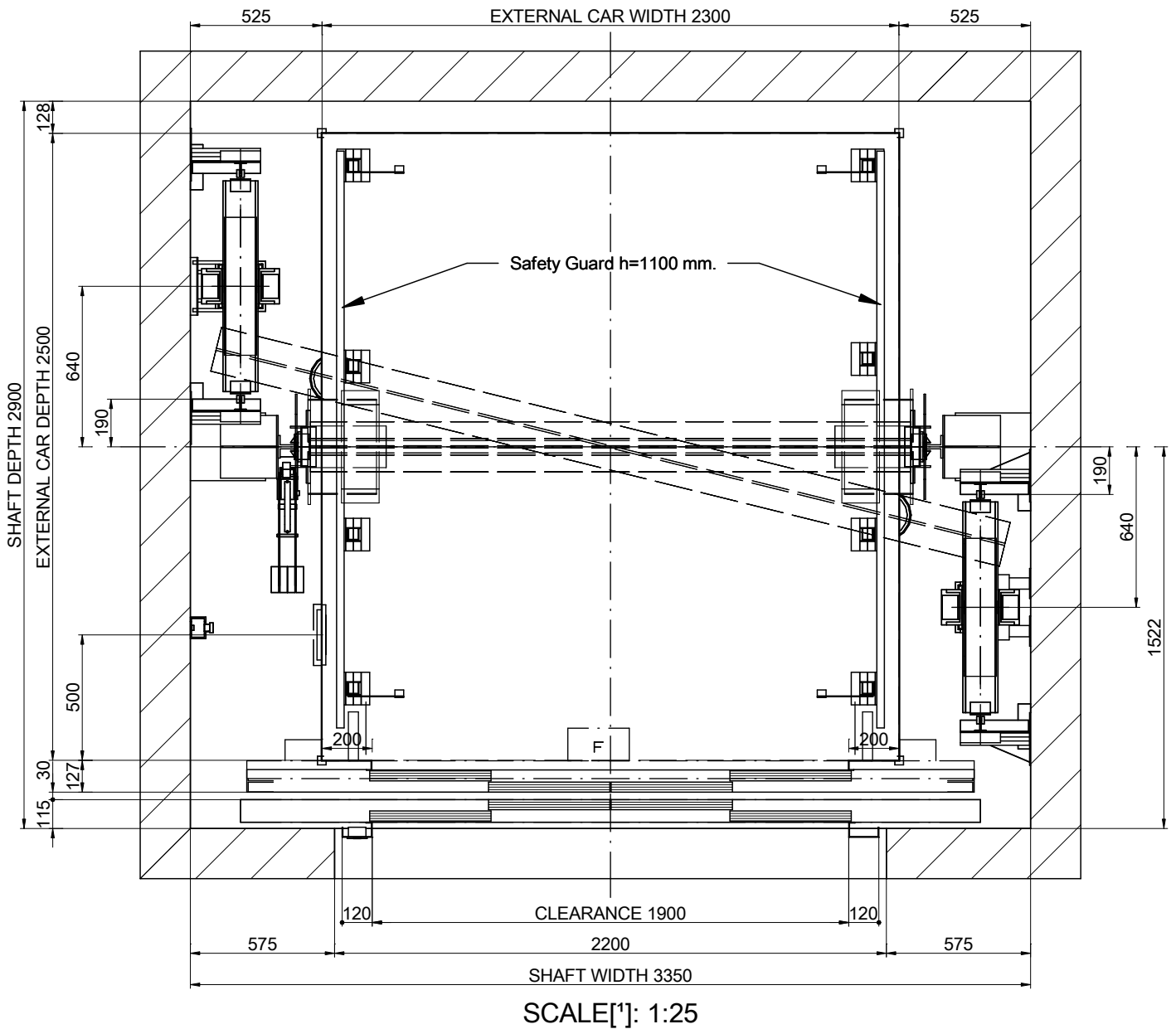

01-PLAN VIEW



DRAWING	DATE	REV.	SHEET	[*] Unbounded dimensions in drawings are indicative and not binding. REFERENCE: MPH_MONTACARGAS_3000_EN	
MP	2017	00	1/8		
MODEL LIFT:				CLIENT:	WORK SITUATION:
MP H					
CAPACITY: [N° PERSONS]		40		<h2>MP LIFTS</h2>	
NOMINAL LOAD: [kg]		3000			
SPEED: [m/s]		0.5			
FREQUENCY: [Hz]		50			
TENSION: [V]		380V [Three-phase]			

01B-PLAN VIEW

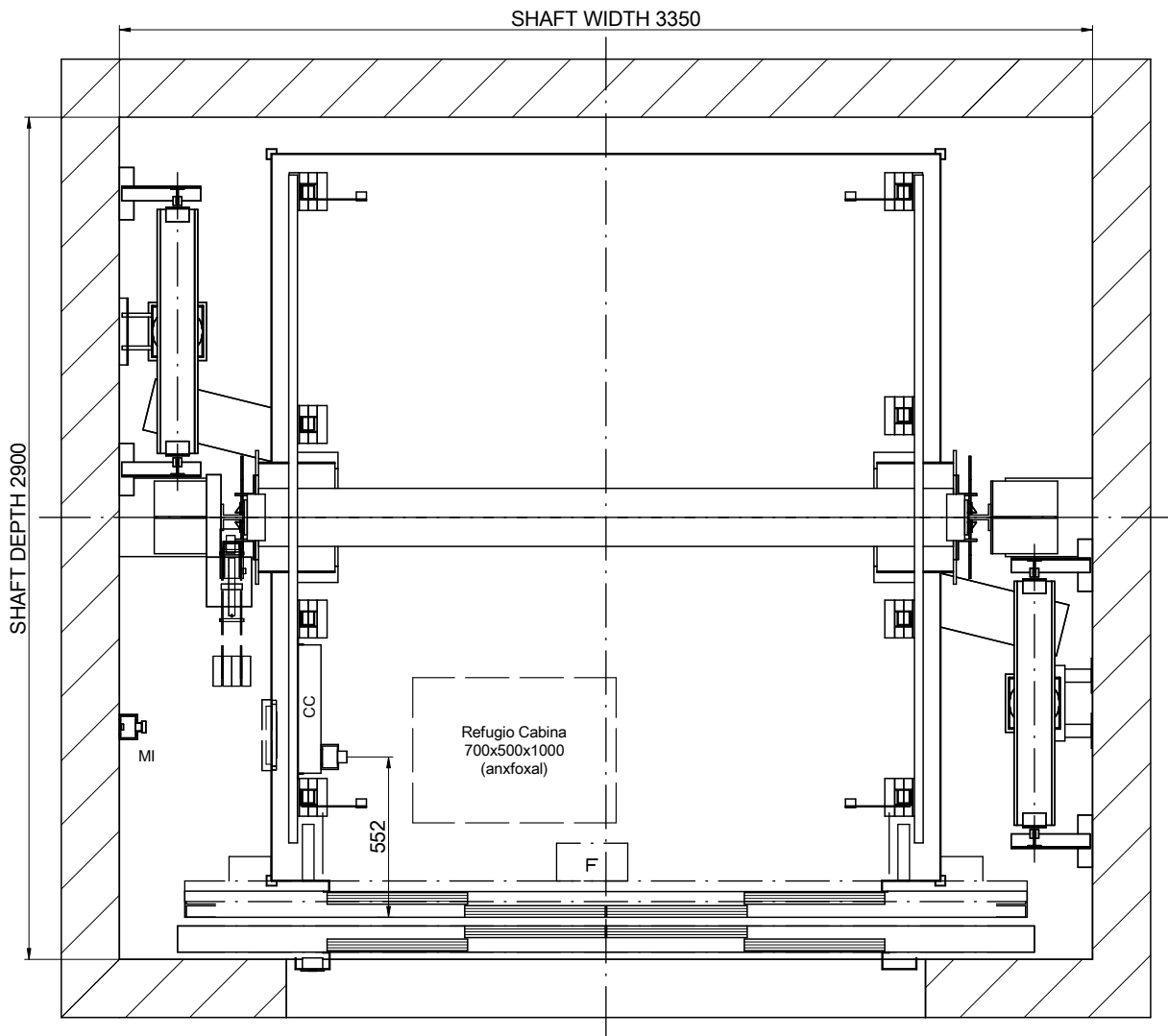

SCALE[*]: 1:25

NOMENCLATURE

CC: Car ceiling connection box
MI: Inspection control station

DRAWING	DATE	REV.	SHEET	[*] Unbounded dimensions in drawings are indicative and not binding. REFERENCE: MPH_MONTACARGAS_3000_EN	
MP	2017	00	2/8		
MODEL LIFT:				CLIENT: WORK SITUATION:	
MP H					
CAPACITY: [N° PERSONS]			40		
NOMINAL LOAD: [kg]			3000		
SPEED: [m/s]			0.5		
FREQUENCY: [Hz]			50		
TENSION: [V]			380V [Three-phase]	MP LIFTS	

02-SIDE VERTICAL SECTION

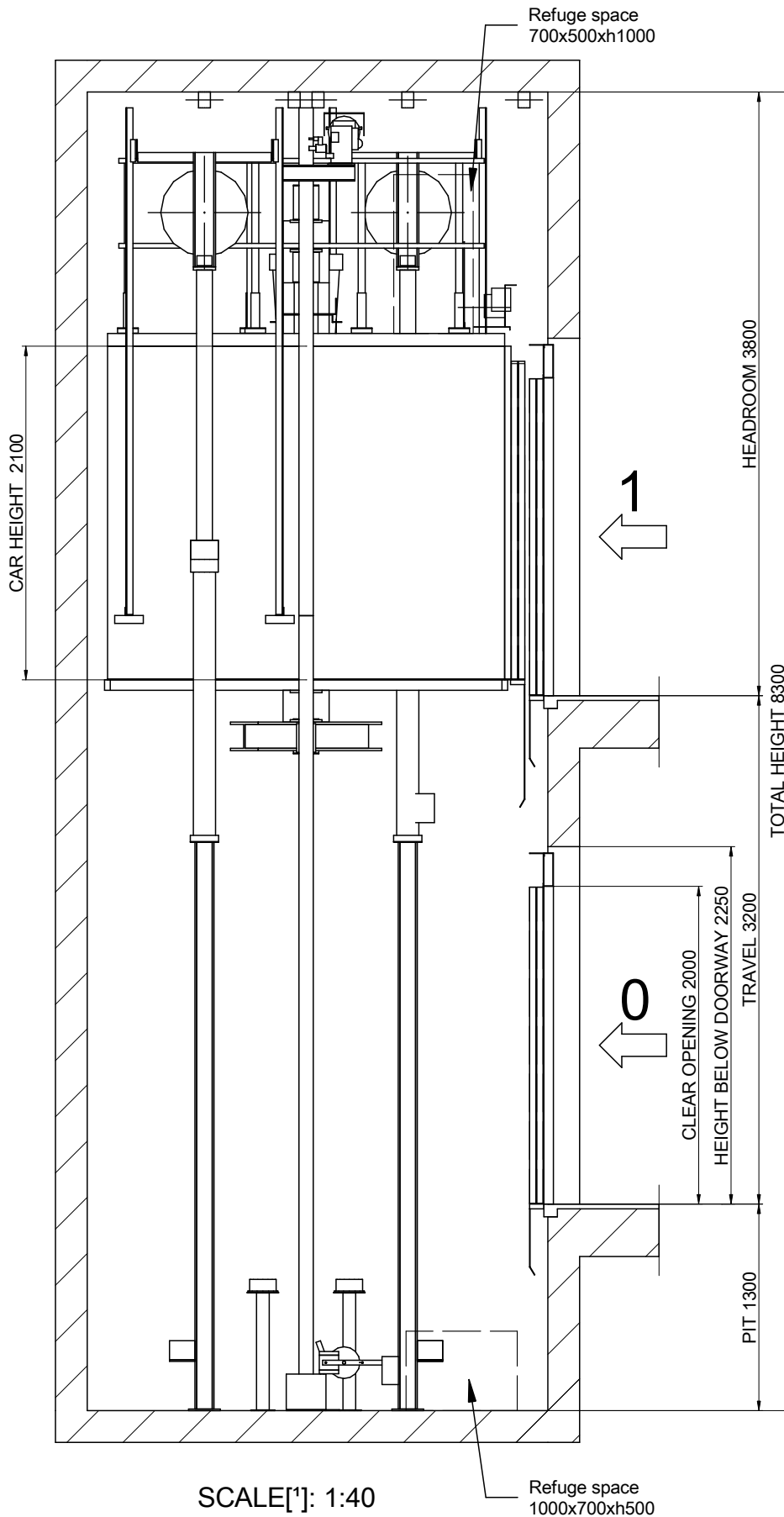
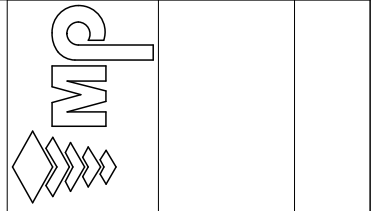

[!] Unbounded dimensions in drawings are indicative and not binding.

REFERENCE:
MPH_MONTACARGAS_3000_EN

CLIENT:
WORK SITUATION:

DRAWING	DATE	REV.	SHEET
MP	2017	00	3/8
MODEL LIFT:			
MP H			
CAPACITY: [N° PERSONS] 40			
NOMINAL LOAD: [kg] 3000			
SPEED: [m/s] 0.5			
FREQUENCY: [Hz] 50			
TENSION: [V] 380V [Three-phase]			

Flat and levelled floor, protected against water leaking.
[EN81-20:2014 5.2.1.9]
Foresee pit access device
[EN81-20:2014 5.2.2.4]
Stop device
[EN81-20:2014 5.2.1.5.1. a]
Inspection control station.
[EN81-20:2014 5.2.1.5.1. b]
Power supply
[EN81-20:2014 5.2.1.5.1. c]
Light switch commuted with the cabinet.
[EN81-20:2014 5.2.1.5.1. d]

SCALE[!]: 1:40

Refuge space
1000x700xh500

MAX DISTANCE
BETWEEN BRACKETS
= 1500 mm



MP LIFTS

04-BEAM AND LIFTING HOOKS

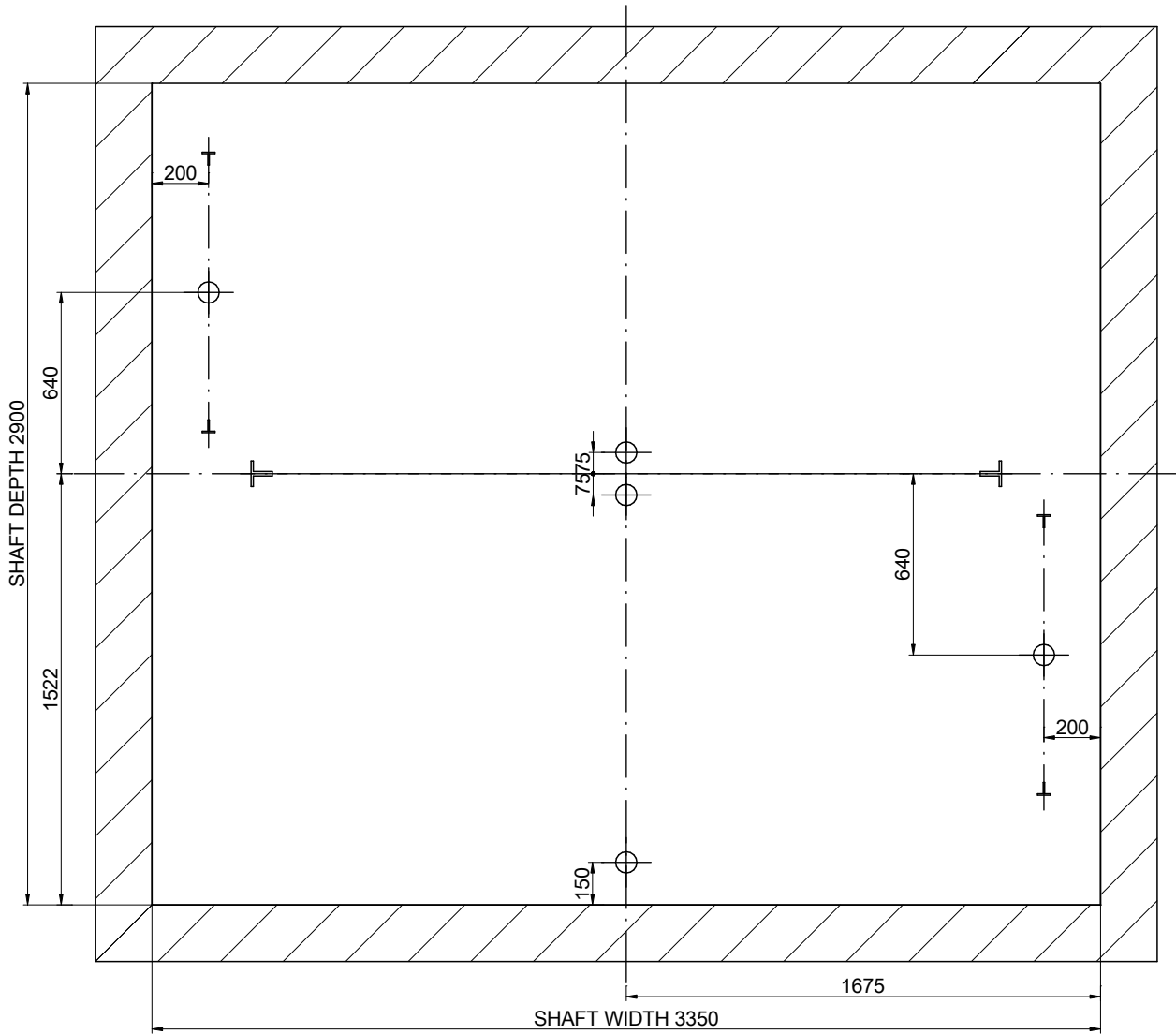
POSITION OF REMOVABLE LIFTING HOOKS ABLE TO SUPPORT
3500 kg EACH ONE SUPPLIED BY CONSTRUCTOR
(RECOMMENDED POSITION LOADHOOKS)



SCALE[1]: 1:25

DRAWING	DATE	REV.	SHEET	[*] Unbounded dimensions in drawings are indicative and not binding.	
MP	2017	00	4/8		
MODEL LIFT:				REFERENCE:	
MP H				MPH_MONTACARGAS_3000_EN	
CAPACITY: [N° PERSONS]				CLIENT:	<p style="text-align: center; font-size: 2em; font-weight: bold;">MP LIFTS</p>
NOMINAL LOAD: [kg]				WORK SITUATION:	
SPEED: [m/s]					
FREQUENCY: [Hz]					
TENSION: [V]					
380V [Three-phase]					

04B-MACHINE ROOM

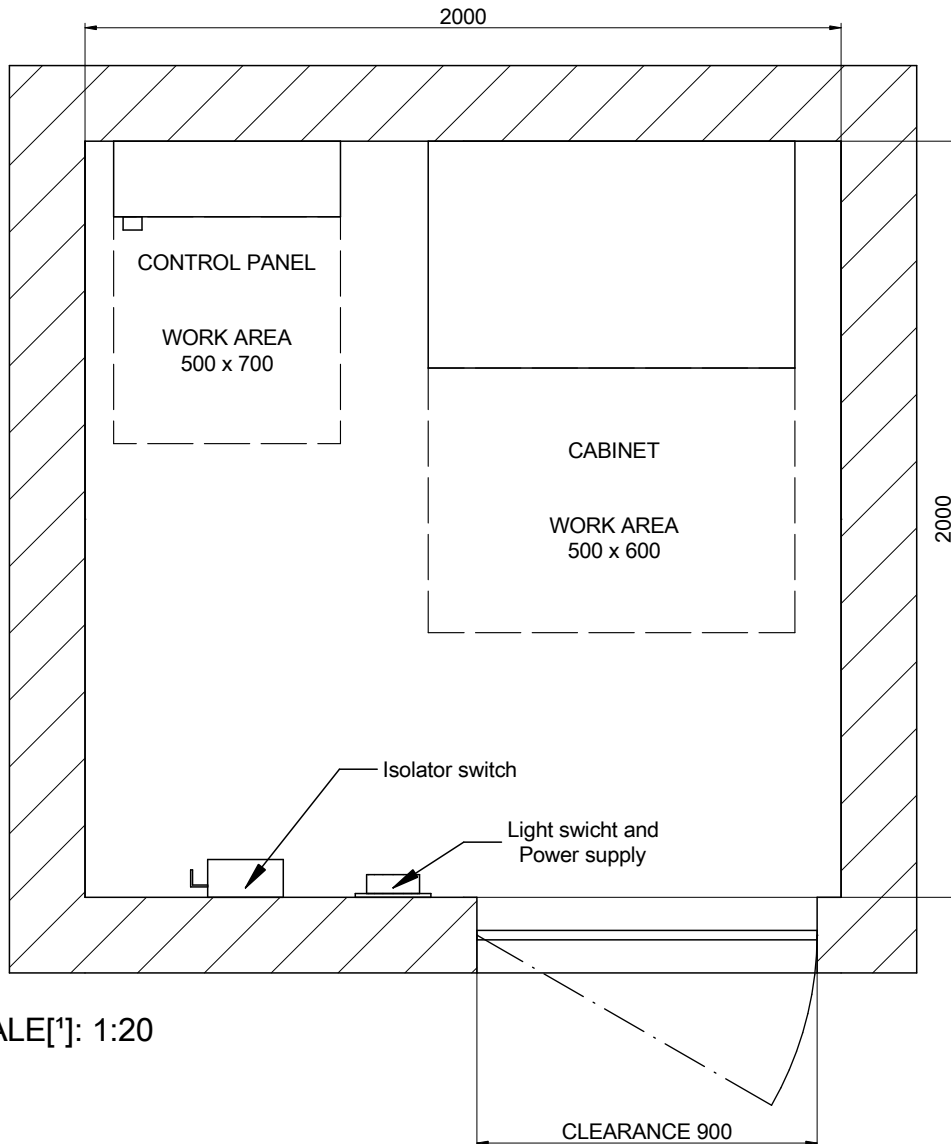

SCALE[*]: 1:20

Minimum machine room height: 2100 mm.
 [EN 81-20:2014 5.2.6.3.2.1]
 Minimum clearance door: 600x2000 mm.
 [EN 81-20:2014 5.2.3.2 a)]

Machine room location:
 Machine room located in floor level:
 [3] Distance controller/shaft:
 Cylinder oil entrance location: 0

DRAWING	DATE	REV.	SHEET	[*] Unbounded dimensions in drawings are indicative and not binding.	
MP	2017	00	5/8	REFERENCE: MPH_MONTACARGAS_3000_EN	
MODEL LIFT:				CLIENT:	WORK SITUATION:
MP H					
CAPACITY: [N° PERSONS]		40		<h2>MP LIFTS</h2>	
NOMINAL LOAD: [kg]		3000			
SPEED: [m/s]		0.5			
FREQUENCY: [Hz]		50			
TENSION: [V]		380V [Three-phase]			

05-PIT LAYOUT

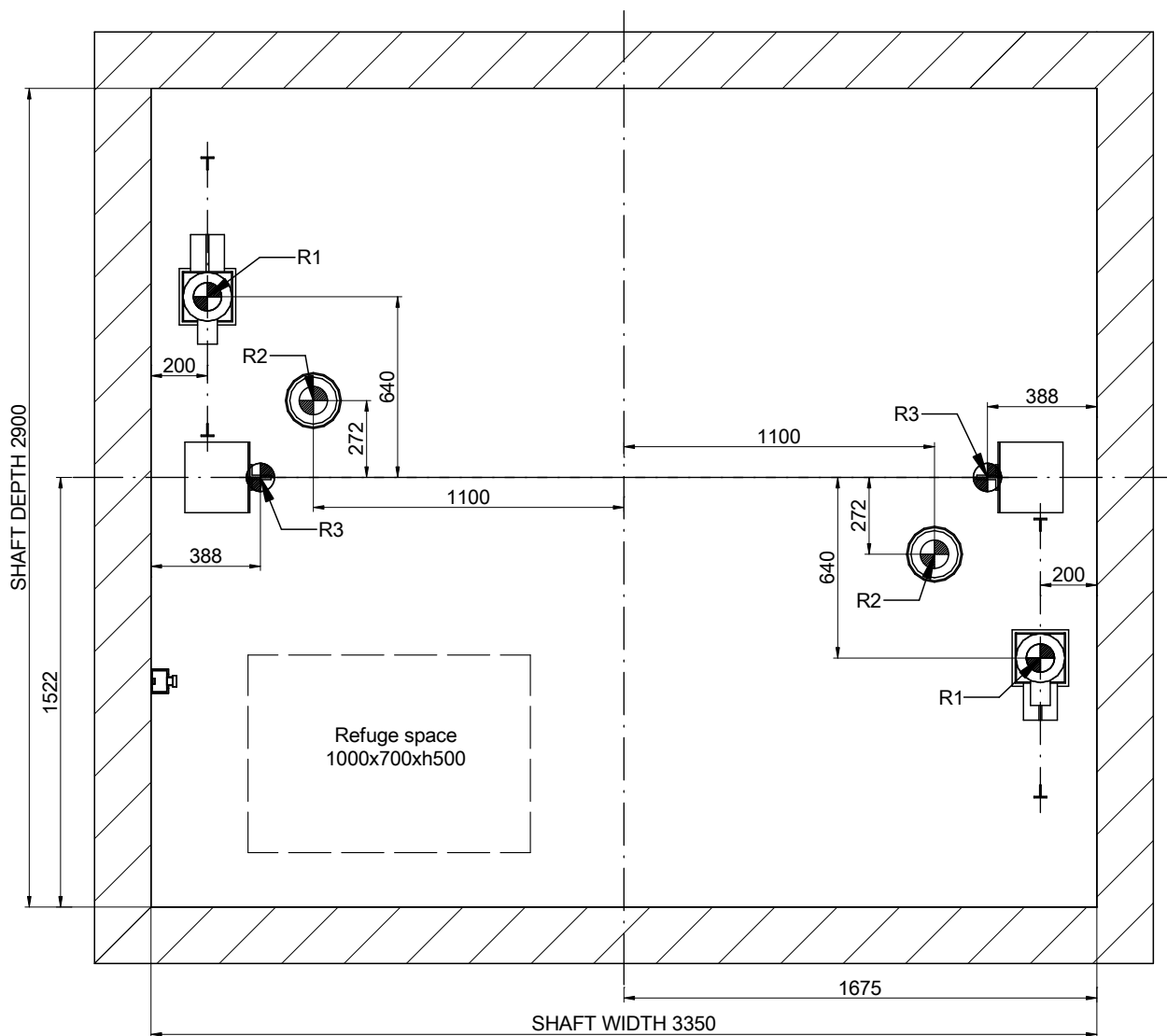

SCALE[*]: 1:25

REACTIONS [N] [max.]					
R1	74900	R2	96250		
R3	75400				
Sx	6350	Sy	7700		

DRAWING	DATE	REV.	SHEET	[*] Unbounded dimensions in drawings are indicative and not binding.		
MP	2017	00	6/8	REFERENCE: MPH_MONTACARGAS_3000_EN		
MODEL LIFT:				CLIENT:		
MP H				WORK SITUATION:		
CAPACITY: [N° PERSONS]			40			
NOMINAL LOAD: [kg]			3000			
SPEED: [m/s]			0.5			
FREQUENCY: [Hz]			50			
TENSION: [V]			380V [Three-phase]	MP LIFTS		

06-DOOR HOLE DETAIL

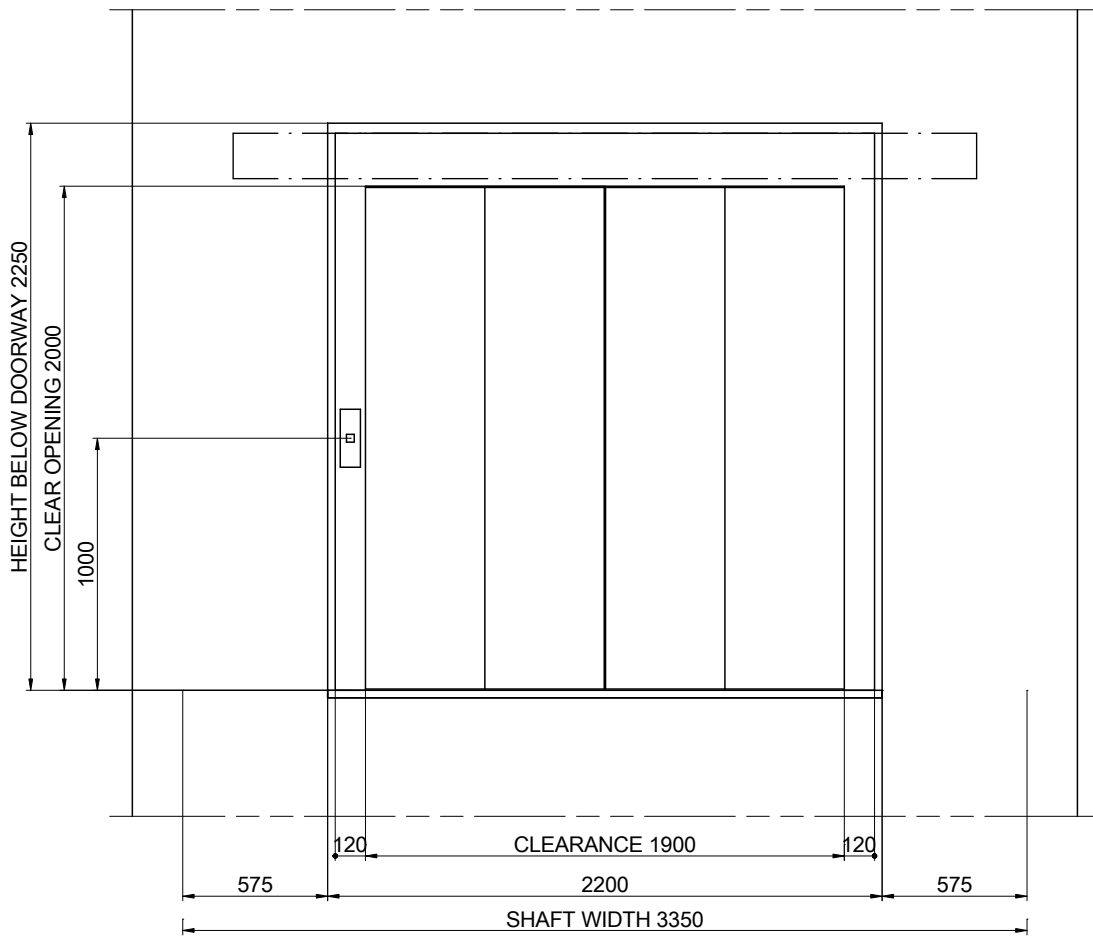

SCALE[*]: 1:30

[2] Uprights recess

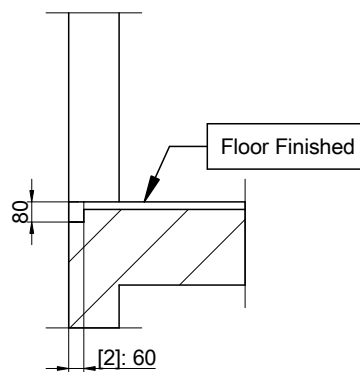

SCALE[*]: 1:30

DRAWING	DATE	REV.	SHEET	[*] Unbounded dimensions in drawings are indicative and not binding.	
MP	2017	00	7/8	REFERENCE: MPH_MONTACARGAS_3000_EN	
MODEL LIFT:				CLIENT:	WORK SITUATION:
MP H					
CAPACITY: [N° PERSONS]		40		<h2>MP LIFTS</h2>	
NOMINAL LOAD: [kg]		3000			
SPEED: [m/s]		0.5			
FREQUENCY: [Hz]		50			
TENSION: [V]		380V [Three-phase]			

07-HEADROOM

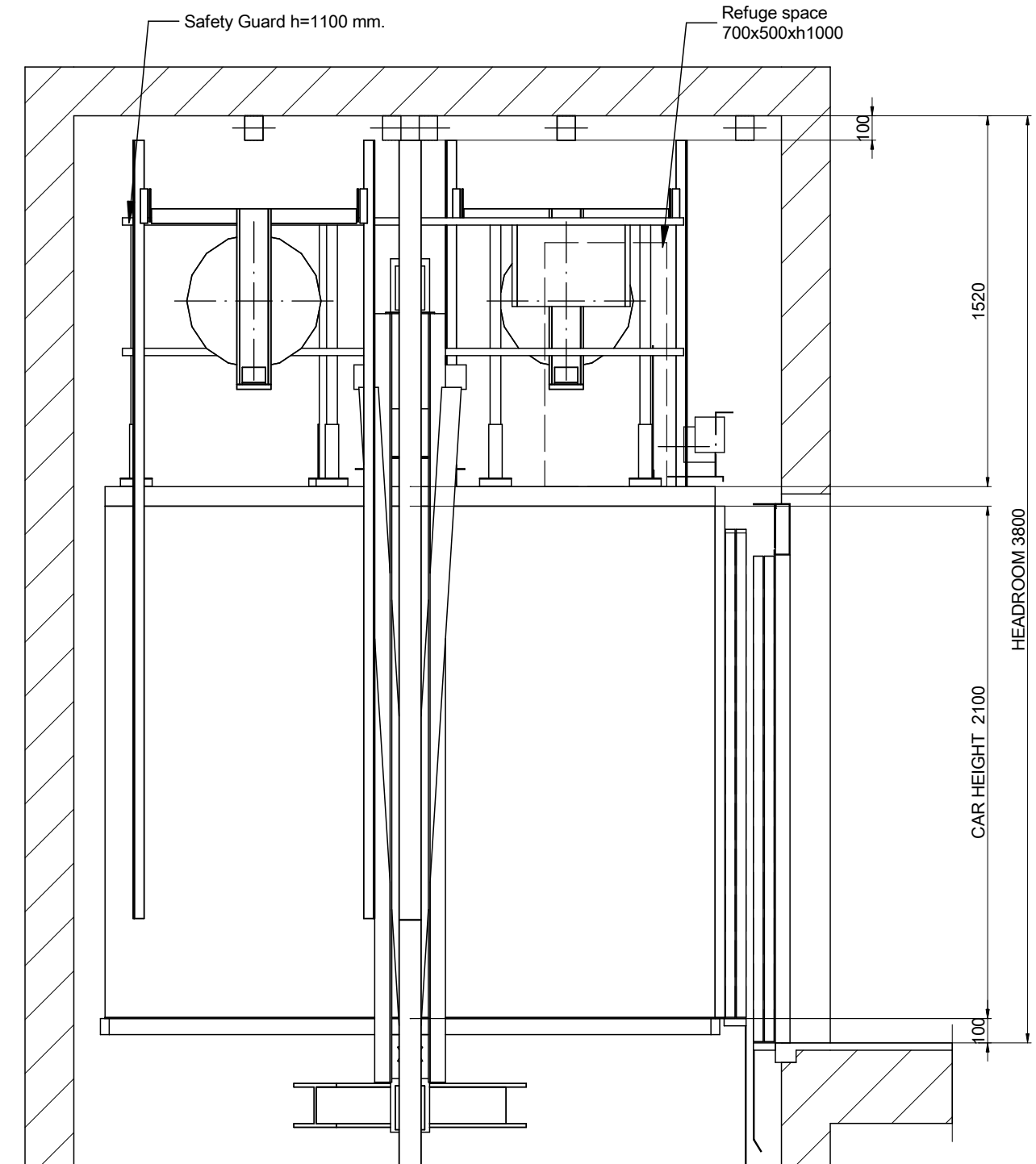

SCALE[*]: 1:25

DRAWING	DATE	REV.	SHEET	[*] Unbounded dimensions in drawings are indicative and not binding. REFERENCE: MPH_MONTACARGAS_3000_EN	
MP	2017	00	8/8		
MODEL LIFT:				CLIENT:	WORK SITUATION:
MP H					
CAPACITY: [N° PERSONS]		40		MP LIFTS	
NOMINAL LOAD: [kg]		3000			
SPEED: [m/s]		0.5			
FREQUENCY: [Hz]		50			
TENSION: [V]		380V [Three-phase]			