

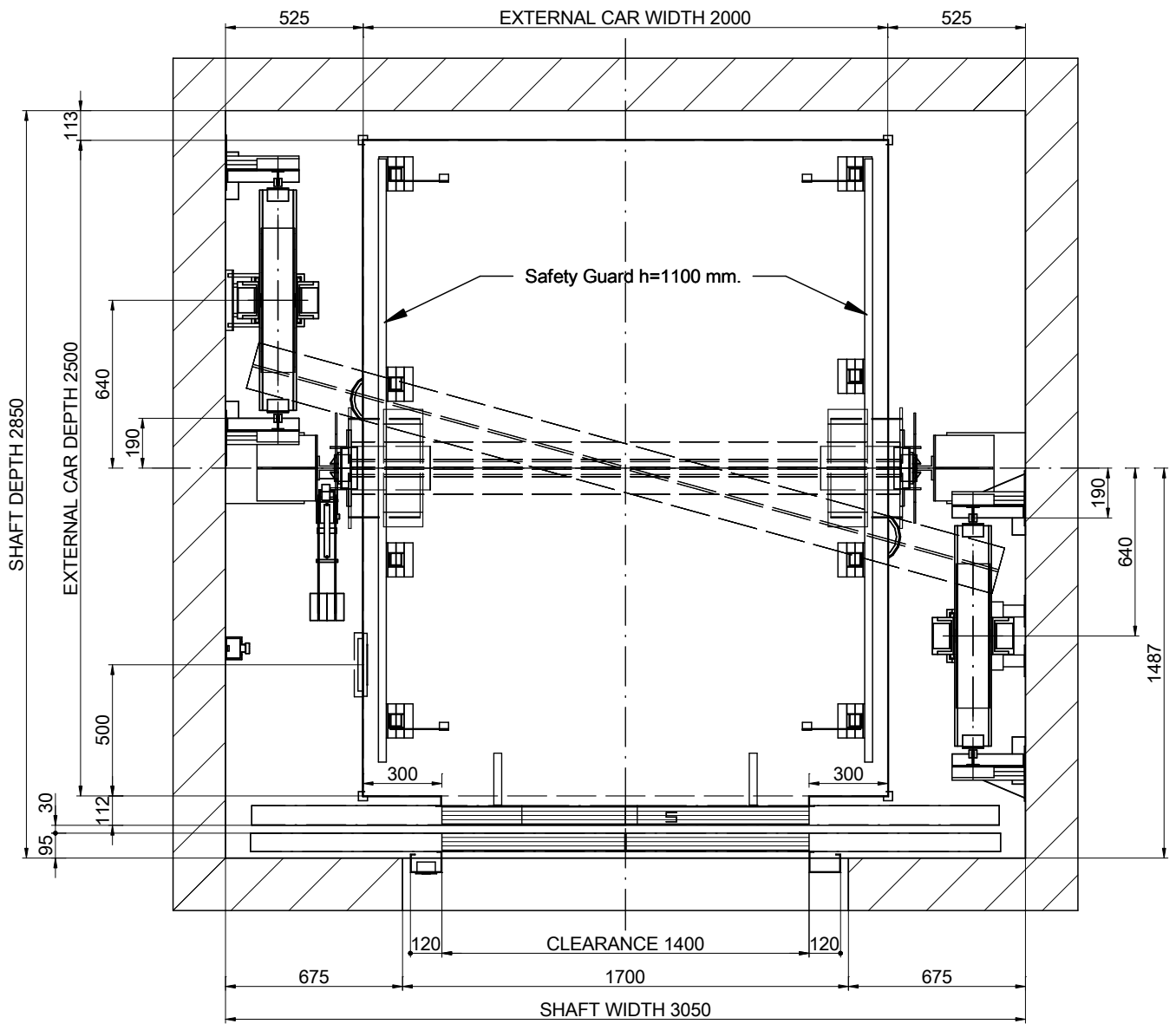

01-PLAN VIEW



DRAWING	DATE	REV.	SHEET	[*] Unbounded dimensions in drawings are indicative and not binding. REFERENCE: MPH_MONTACARGAS_2500_EN	
MP	2017	00	1/8		
MODEL LIFT:				CLIENT:	WORK SITUATION:
MP H					
CAPACITY: [N° PERSONS]		33		<h2>MP LIFTS</h2>	
NOMINAL LOAD: [kg]		2500			
SPEED: [m/s]		0.5			
FREQUENCY: [Hz]		50			
TENSION: [V]		380V [Three-phase]			

01B-PLAN VIEW

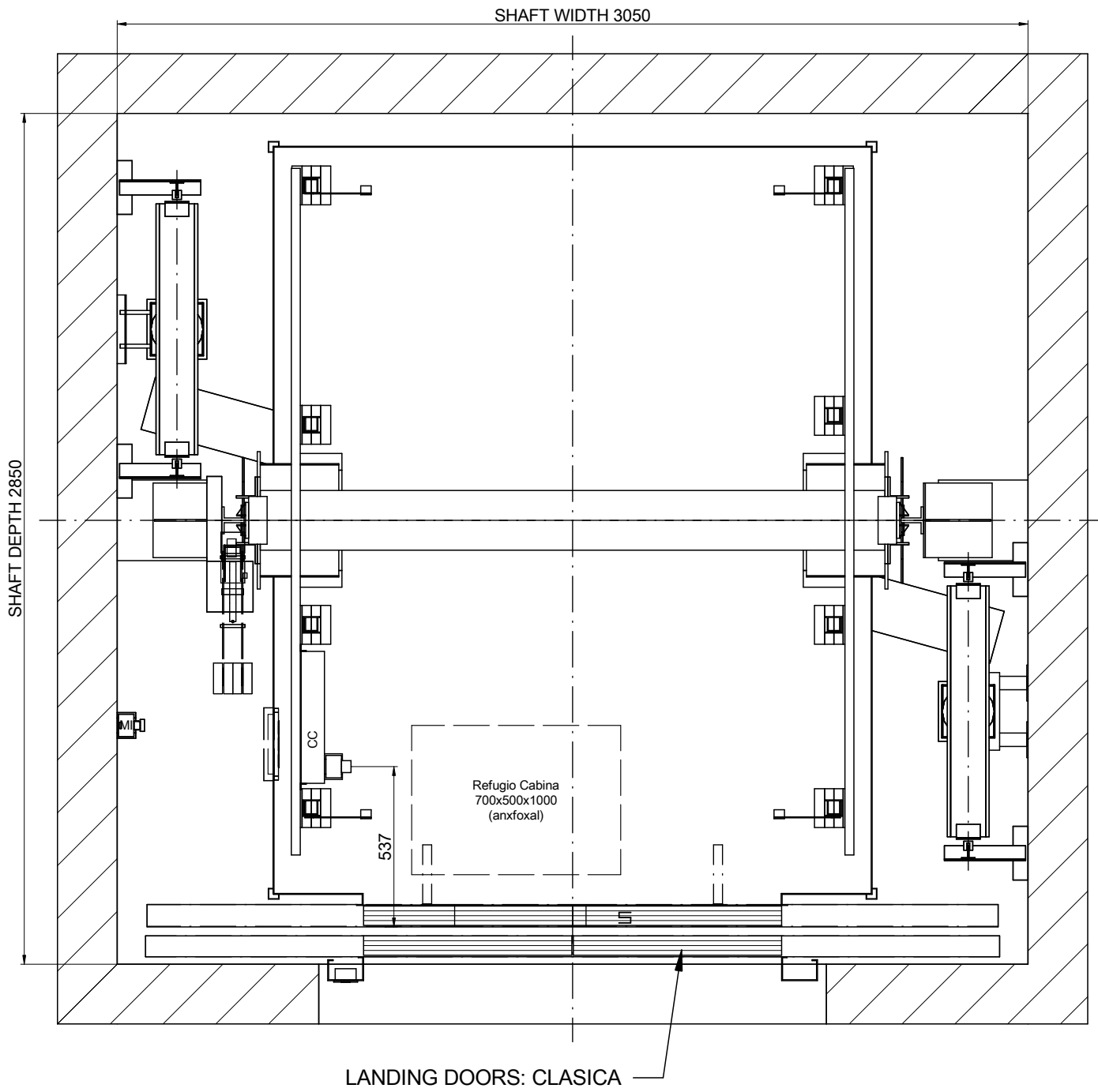

SCALE[*]: 1:20

NOMENCLATURE
 CC: Car ceiling connection box
 MI: Inspection control station

DRAWING	DATE	REV.	SHEET	[*] Unbounded dimensions in drawings are indicative and not binding. REFERENCE: MPH_MONTACARGAS_2500_EN	
MP	2017	00	2/8		
MODEL LIFT:				CLIENT:	WORK SITUATION:
MP H					
CAPACITY: [N° PERSONS]			33	<h2>MP LIFTS</h2>	
NOMINAL LOAD: [kg]			2500		
SPEED: [m/s]			0.5		
FREQUENCY: [Hz]			50		
TENSION: [V]		380V [Three-phase]			

02-SIDE VERTICAL SECTION

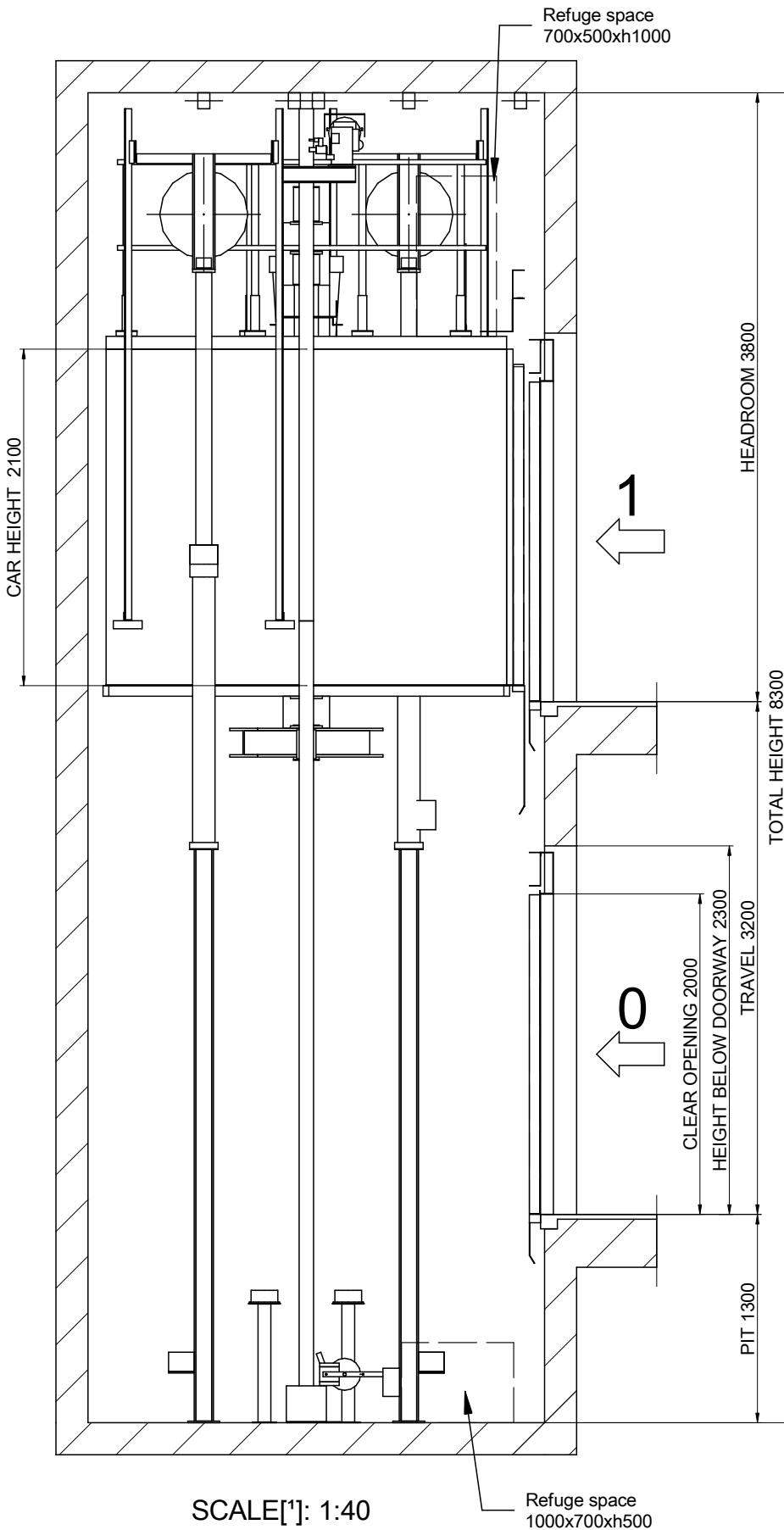
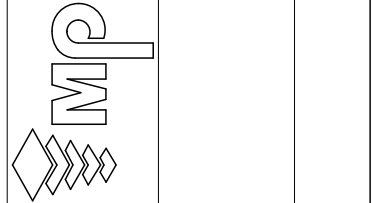

[1] Unbounded dimensions in drawings are indicative and not binding.

REFERENCE:

MPH_MONTACARGAS_2500_EN

CLIENT:
WORK SITUATION:

DRAWING	DATE	REV.	SHEET
MP	2017	00	3/8
MODEL LIFT:			
MP H			
CAPACITY: [N° PERSONS] 33			
NOMINAL LOAD: [kg] 2500			
SPEED: [m/s] 0.5			
FREQUENCY: [Hz] 50			
TENSION: [V] 380V [Three-phase]			

MP LIFTS

Flat and levelled floor, protected against water leaking.
[EN81-20:2014 5.2.1.9]
Foresee pit access device
[EN81-20:2014 5.2.2.4]
Stop device
[EN81-20:2014 5.2.1.5.1. a]
Inspection control station.
[EN81-20:2014 5.2.1.5.1. b]
Power supply
[EN81-20:2014 5.2.1.5.1. c]
Light switch commuted with the cabinet.
[EN81-20:2014 5.2.1.5.1. d]

MAX DISTANCE BETWEEN BRACKETS = 1500 mm

04-BEAM AND LIFTING HOOKS

POSITION OF REMOVABLE LIFTING HOOKS ABLE TO SUPPORT
3500 kg EACH ONE SUPPLIED BY CONSTRUCTOR
(RECOMMENDED POSITION LOADHOOKS)

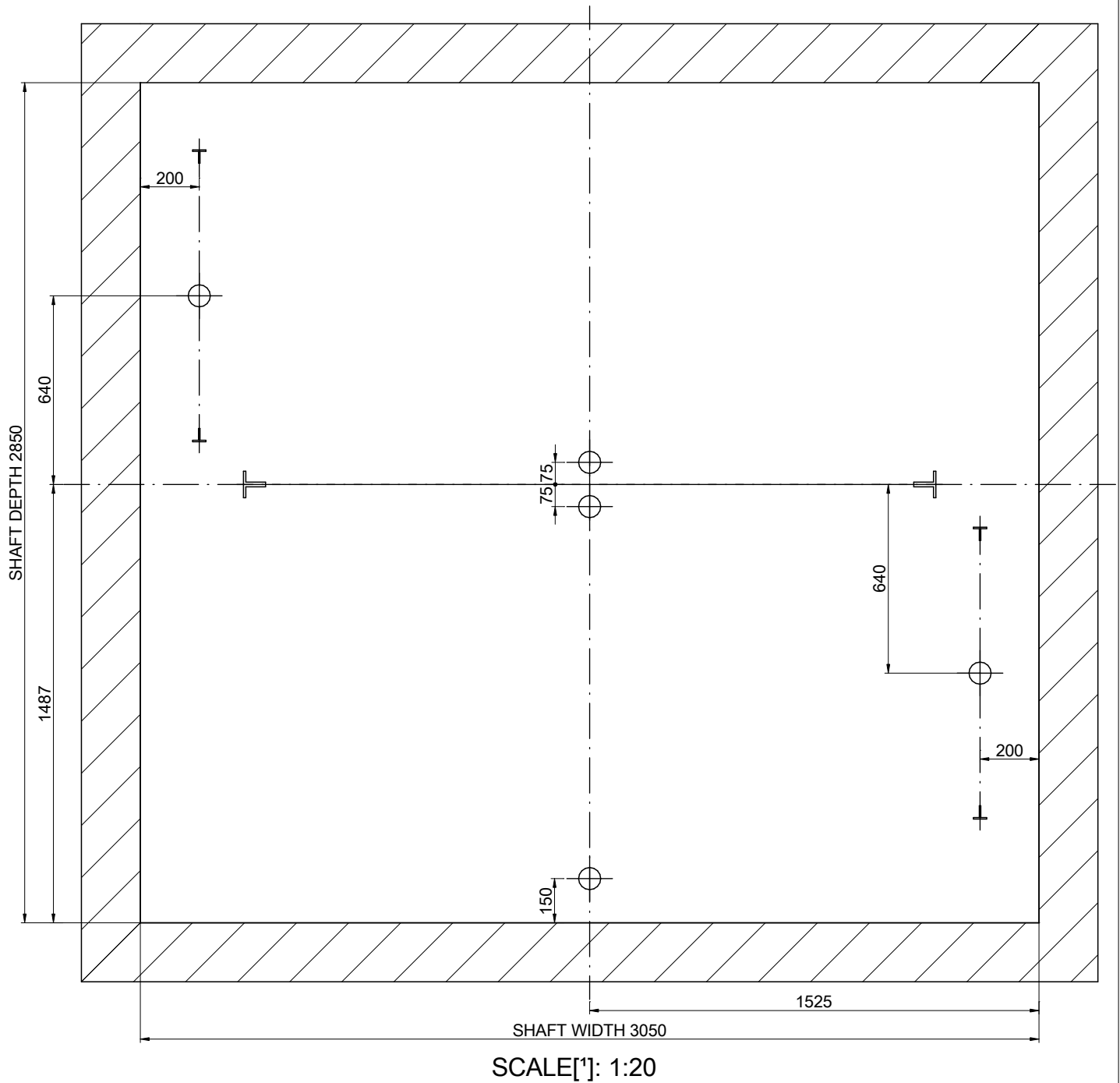

DRAWING	DATE	REV.	SHEET	[*] Unbounded dimensions in drawings are indicative and not binding.	
MP	2017	00	4/8	REFERENCE: MPH_MONTACARGAS_2500_EN	
MODEL LIFT:				CLIENT: WORK SITUATION:	<p style="text-align: center; font-size: 2em; font-weight: bold;">MP LIFTS</p>
MP H					
CAPACITY: [N° PERSONS]			33		
NOMINAL LOAD: [kg]			2500		
SPEED: [m/s]			0.5		
FREQUENCY: [Hz]			50		
TENSION: [V]			380V [Three-phase]		

04B-MACHINE ROOM

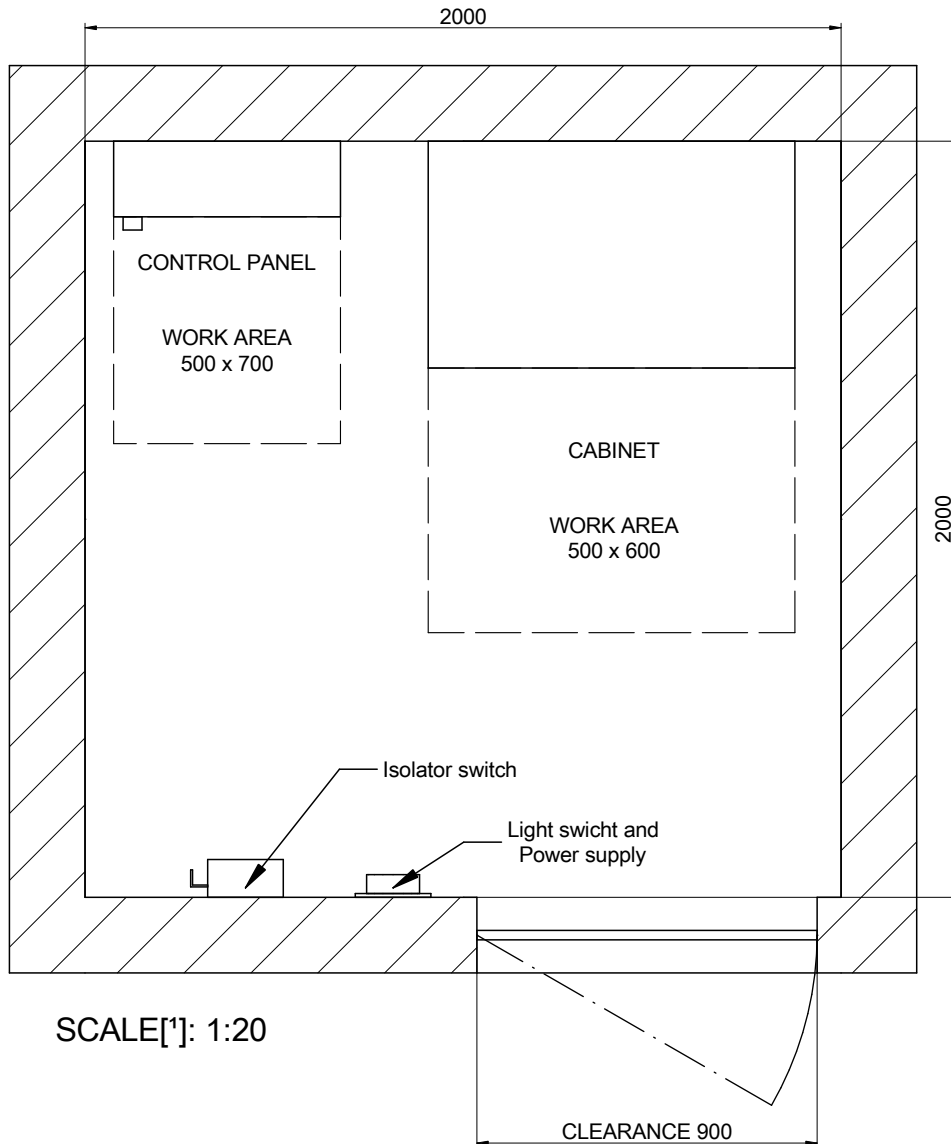

Minimum machine room height: 2100 mm.
[EN 81-20:2014 5.2.6.3.2.1]
Minimum clearance door: 600x2000 mm.
[EN 81-20:2014 5.2.3.2 a)]

Machine room location:
Machine room located in floor level:
[3] Distance controller/shaft:
Cylinder oil entrance location: 0

DRAWING	DATE	REV.	SHEET	[*] Unbounded dimensions in drawings are indicative and not binding.	
MP	2017	00	5/8	REFERENCE: MPH_MONTACARGAS_2500_EN	
MODEL LIFT:				CLIENT:	WORK SITUATION:
MP H					
CAPACITY: [N° PERSONS]			33	<h2>MP LIFTS</h2>	
NOMINAL LOAD: [kg]			2500		
SPEED: [m/s]			0.5		
FREQUENCY: [Hz]			50		
TENSION: [V]			380V [Three-phase]		

05-PIT LAYOUT

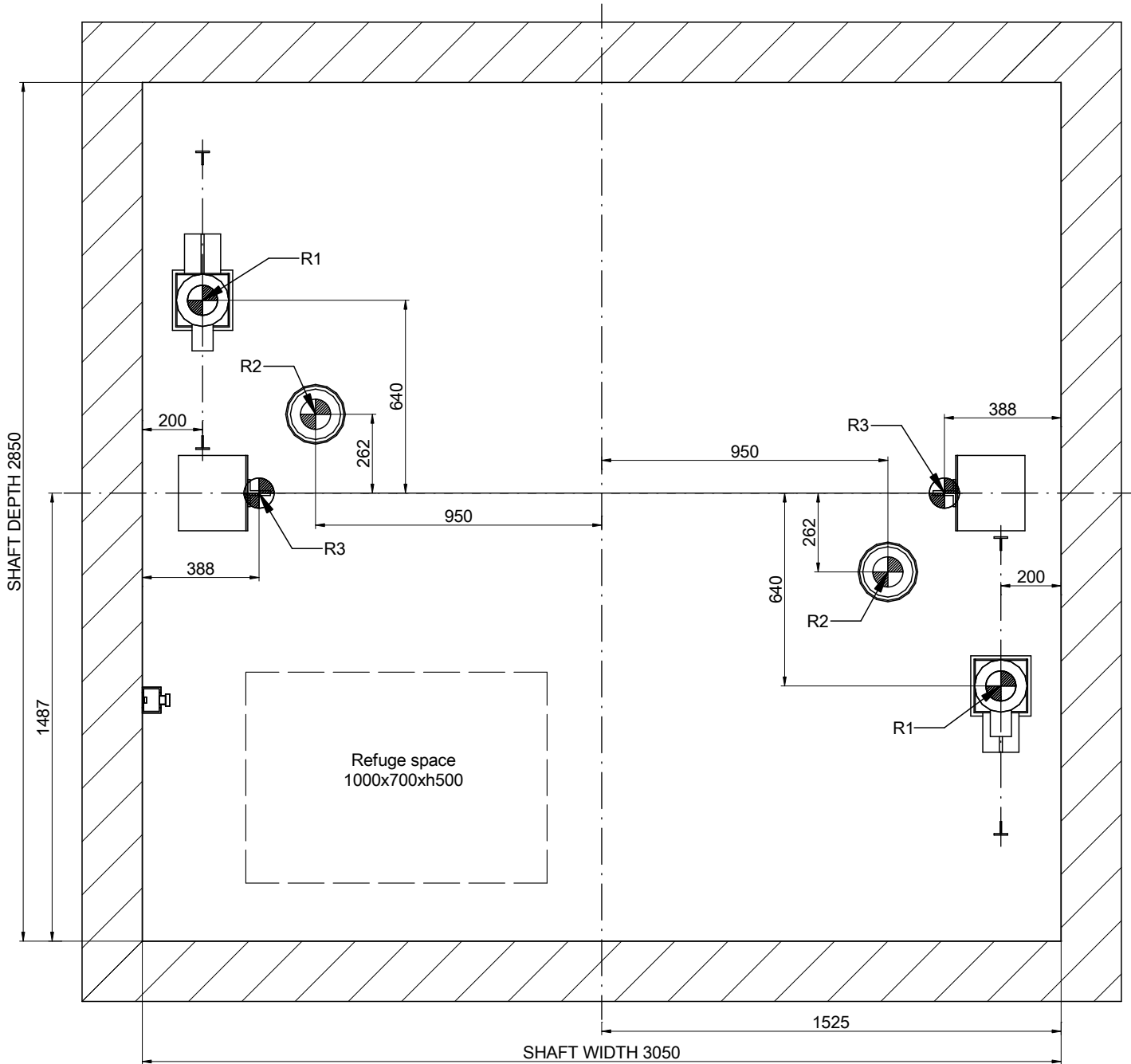

SCALE[*]: 1:20

REACTIONS [N] [max.]			
R1	64400	R2	82500
R3	64700		
Sx	5350	Sy	5550

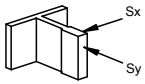

DRAWING	DATE	REV.	SHEET
MP	2017	00	6/8
MODEL LIFT:			
MP H			
CAPACITY: [N° PERSONS]			33
NOMINAL LOAD: [kg]			2500
SPEED: [m/s]			0.5
FREQUENCY: [Hz]			50
TENSION: [V]			380V [Three-phase]

[*] Unbounded dimensions in drawings are indicative and not binding.

REFERENCE:
MPH_MONTACARGAS_2500_EN

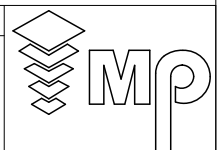

CLIENT:
WORK SITUATION:

MP LIFTS

06-DOOR HOLE DETAIL

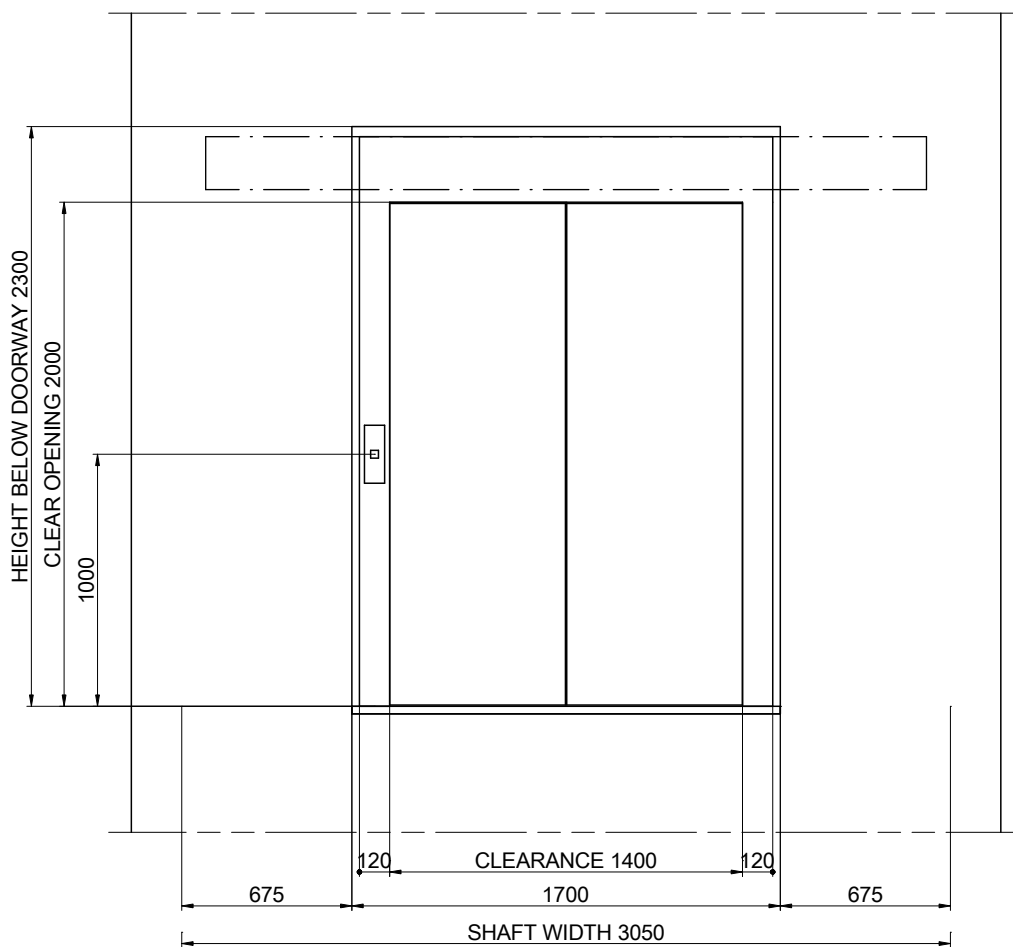

SCALE[*]: 1:30

[2] Uprights recess

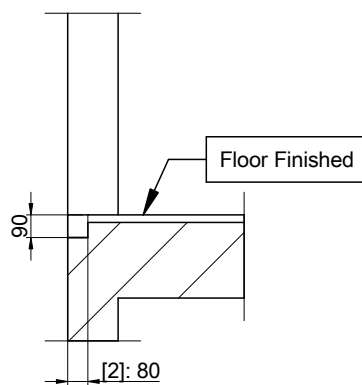

SCALE[*]: 1:30

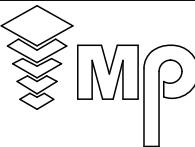
DRAWING	DATE	REV.	SHEET	[*] Unbounded dimensions in drawings are indicative and not binding.	
MP	2017	00	7/8	REFERENCE: MPH_MONTACARGAS_2500_EN	
MODEL LIFT:				CLIENT: WORK SITUATION:	MP LIFTS
MP H					
CAPACITY: [N° PERSONS]			33		
NOMINAL LOAD: [kg]			2500		
SPEED: [m/s]			0.5		
FREQUENCY: [Hz]			50		
TENSION: [V]		380V [Three-phase]			

07-HEADROOM

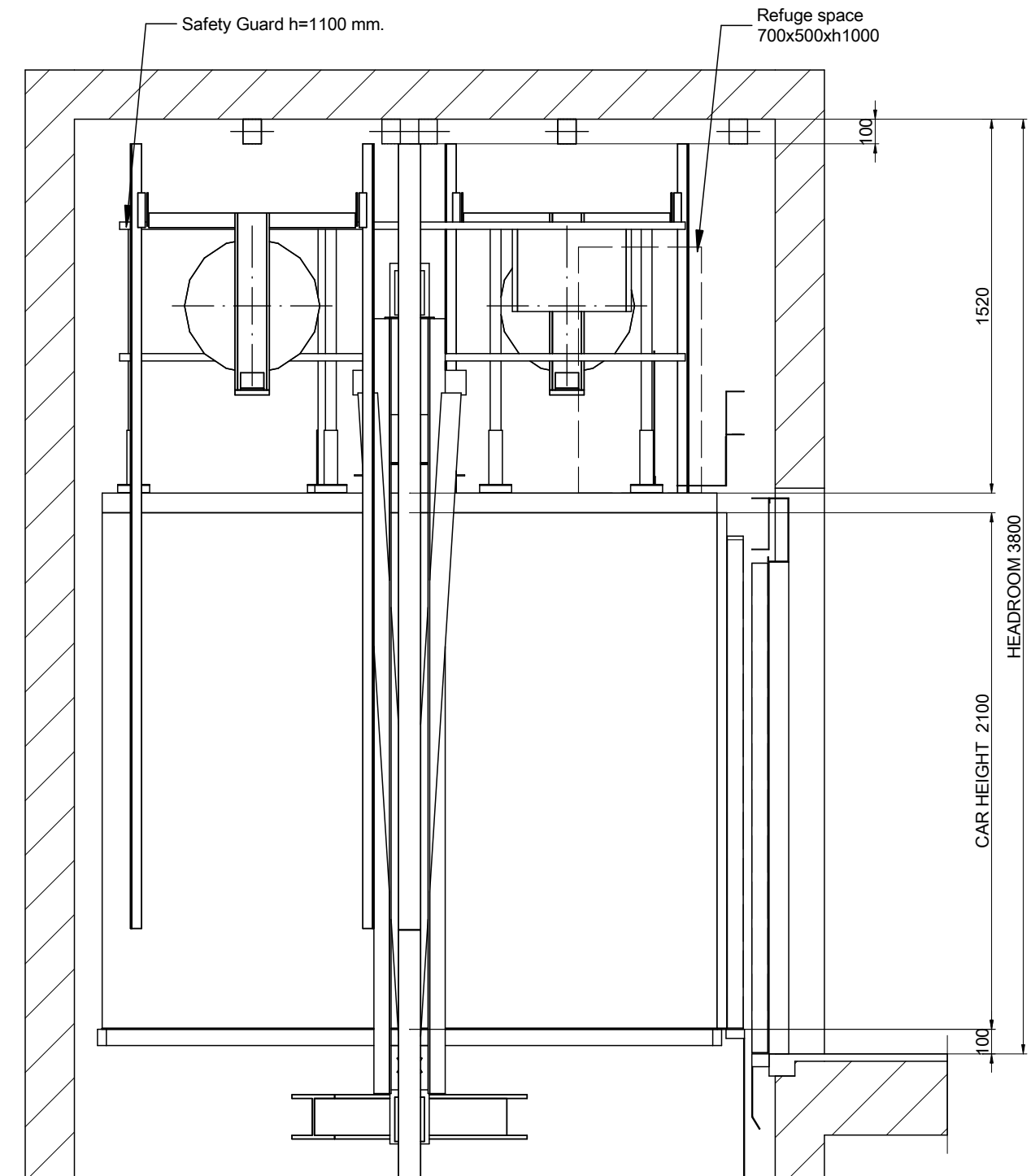

DRAWING	DATE	REV.	SHEET	[*] Unbounded dimensions in drawings are indicative and not binding.	
MP	2017	00	8/8		
MODEL LIFT:				REFERENCE:	
MP H				MPH_MONTACARGAS_2500_EN	
CAPACITY: [N° PERSONS]				CLIENT:	
NOMINAL LOAD: [kg]				WORK SITUATION:	
SPEED: [m/s]					
FREQUENCY: [Hz]					
TENSION: [V]					
380V [Three-phase]					
					MP LIFTS