

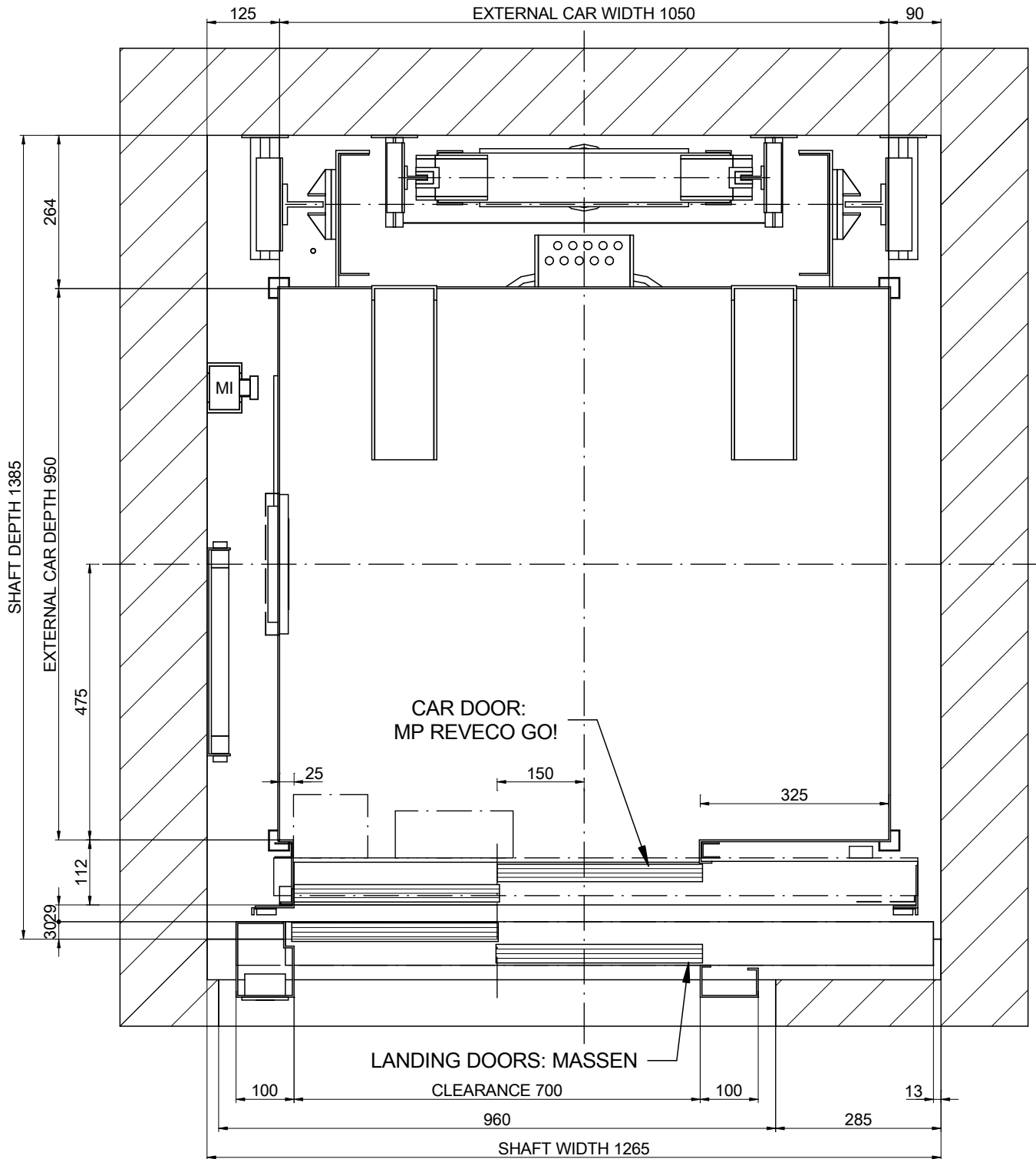

# 01-PLAN VIEW



## NOMENCLATURE

CC: Car ceiling connection box  
 MI: Inspection control station

SCALE[\*]: 1:10

DRAWING	DATE	REV.	SHEET	[*] Unbounded dimensions in drawings are indicative and not binding. REFERENCE: MPGO!FLEXXLFONDO375C_EN	
MP	2017	00	1/7		
MODEL LIFT:				CLIENT:	WORK SITUATION:
MP GO! FLEX XL					
CAPACITY: [N° PERSONS]			5	<h1>MP LIFTS</h1>	
NOMINAL LOAD: [kg]			375		
SPEED: [m/s]			1		
FREQUENCY: [Hz]			50		
TENSION: [V]			380V [Three-phase]		

# 02-SIDE VERTICAL SECTION

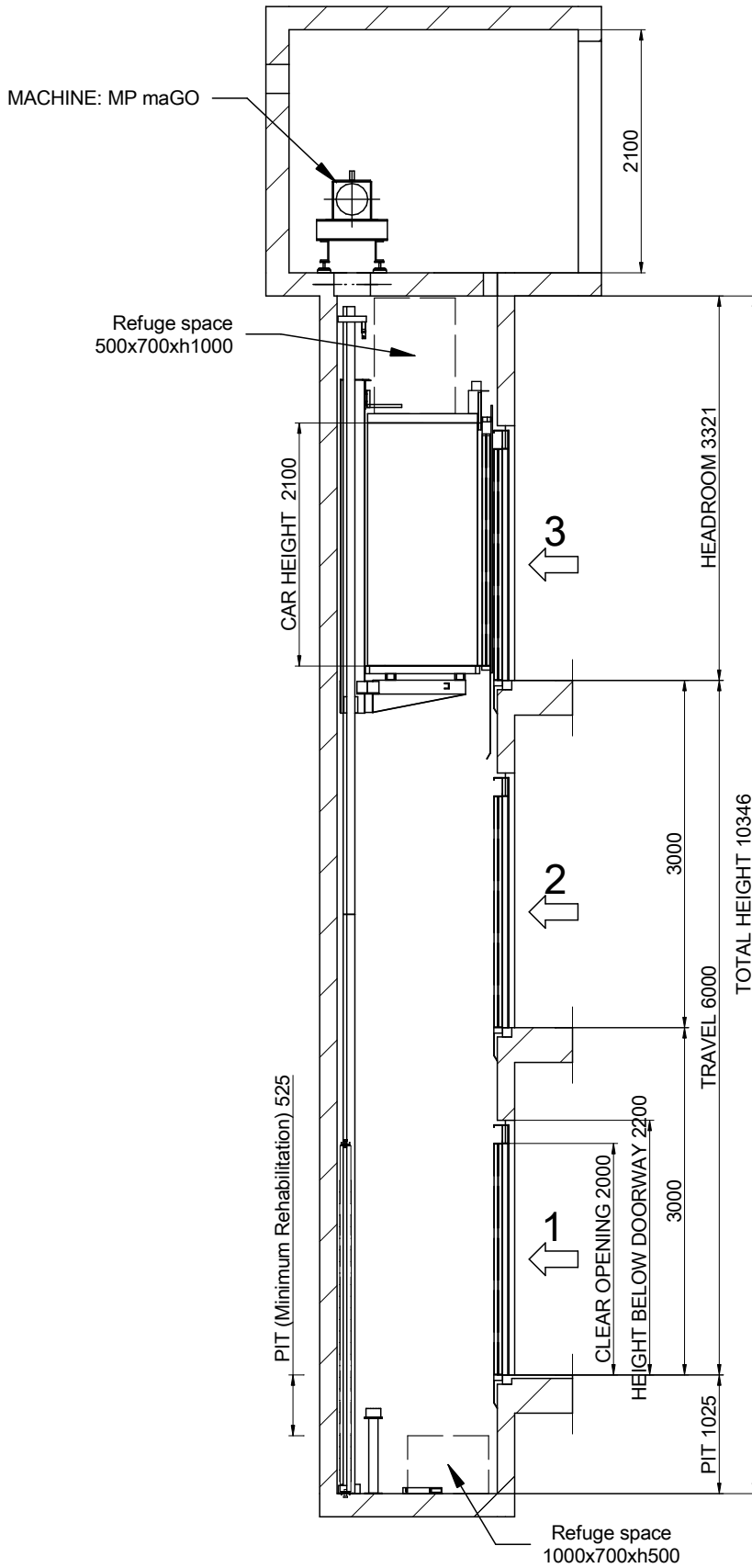

SCALE[\*]: 1:60

DRAWING		DATE		REV.	SHEET
		2017	00	2/7	
MP		REFERENCE: MPGOIFLEXLFFONDO375C_EN			
MODEL LIFT:		MP GO! FLEX XL			
CAPACITY: [N° PERSONS]		5			
NOMINAL LOAD: [kg]		375			
SPEED: [m/s]		1			
FREQUENCY: [Hz]		50			
TENSION: [V]		380V [Three-phase]			
CLIENT:		WORK SITUATION:			
MP LIFTS					

Flat and levelled floor, protected against water leaking.  
 [EN81-20:2014 5.2.1.9]  
 Foresee pit access device  
 [EN81-20:2014 5.2.2.4]  
 Stop device  
 [EN81-20:2014 5.2.1.5.1. a]  
 Inspection control station.  
 [EN81-20:2014 5.2.1.5.1. b]  
 Power supply  
 [EN81-20:2014 5.2.1.5.1. c]  
 Light swicht  
 commuted with the cabinet.  
 [EN81-20:2014 5.2.1.5.1. d]



# 04-SLAB LAYOUT

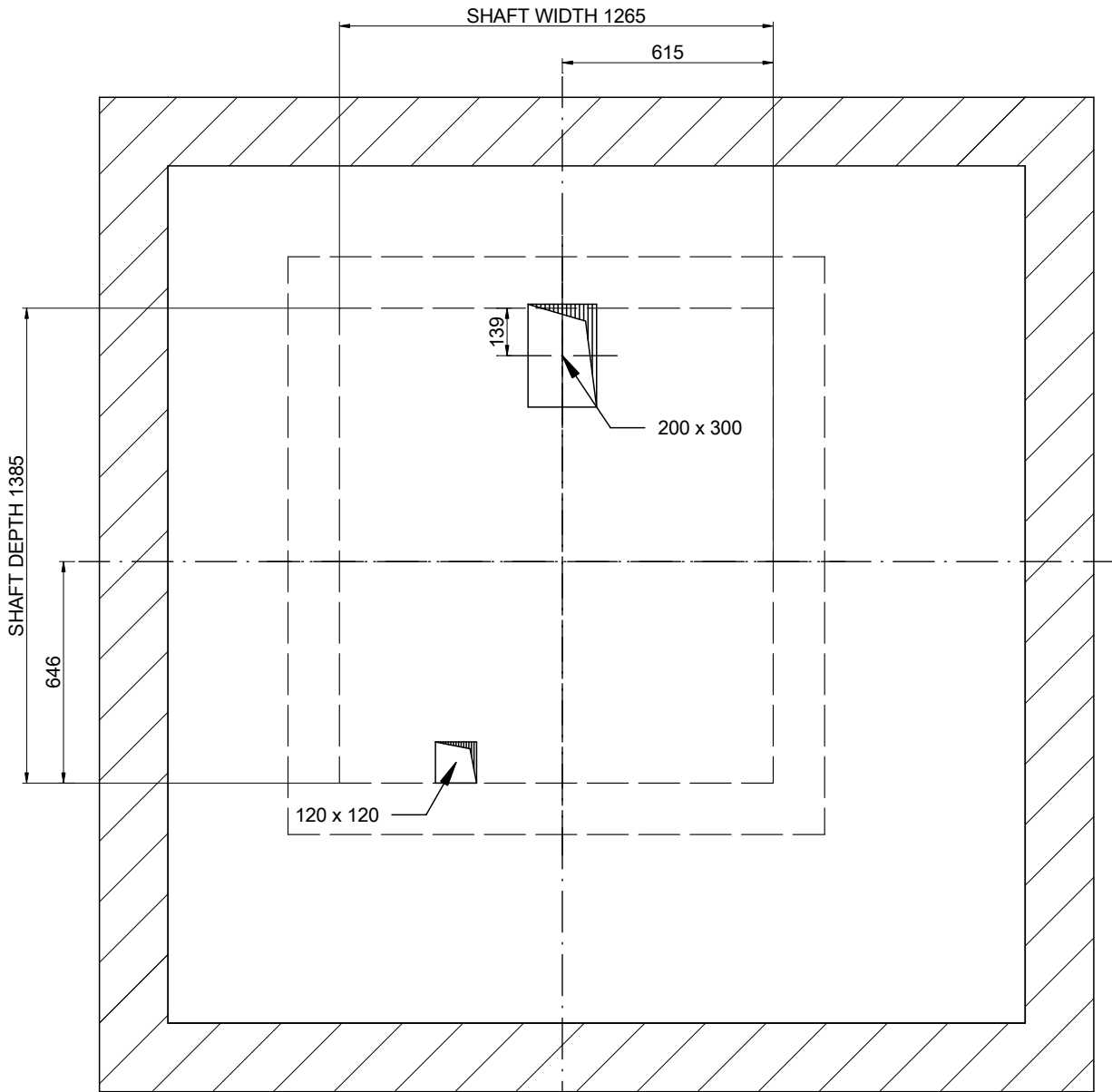

SCALE[\*]: 1:20

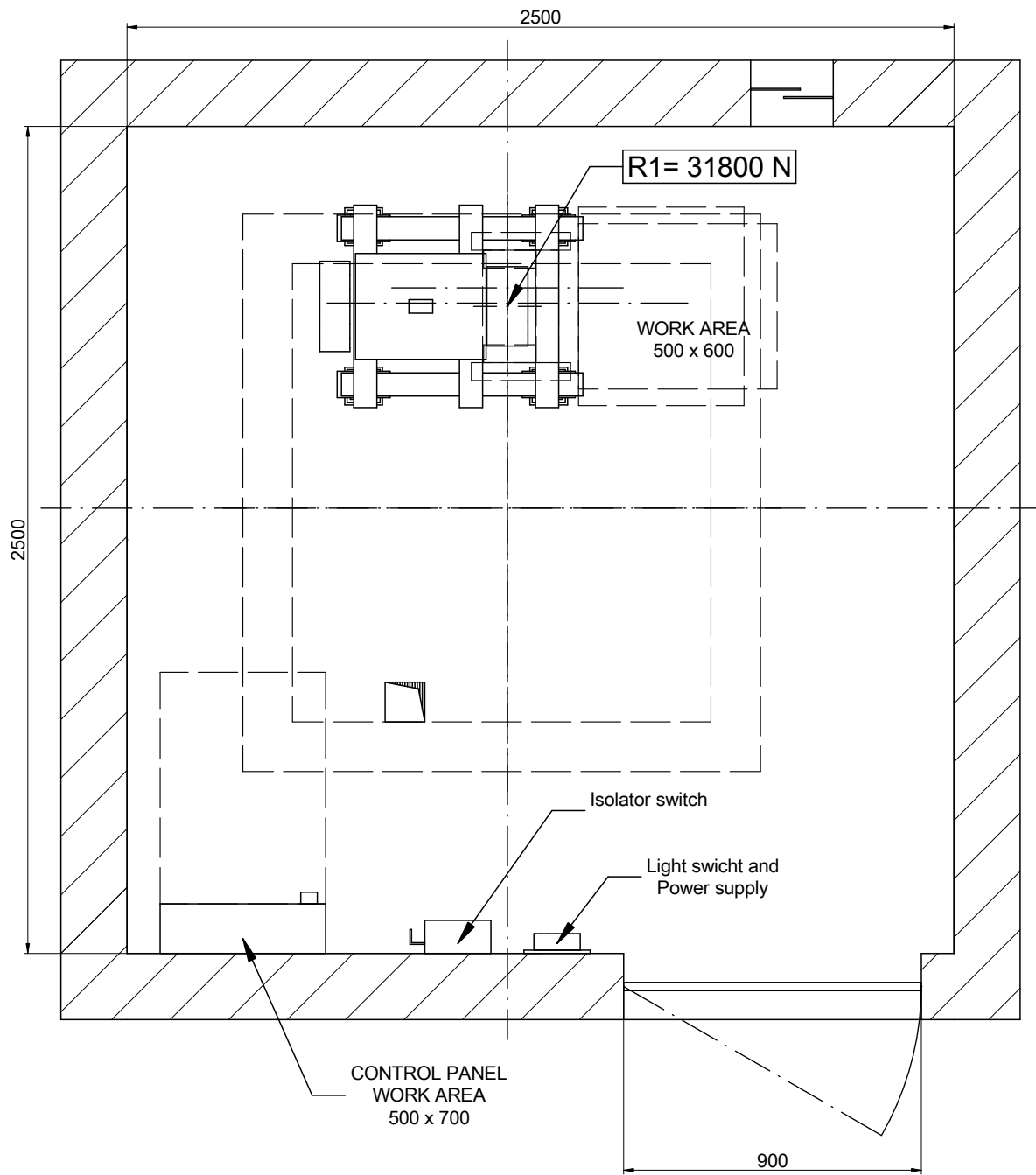

DRAWING	DATE	REV.	SHEET	[*] Unbounded dimensions in drawings are indicative and not binding.	
MP	2017	00	3/7	REFERENCE: MPGO!FLEXXLFONDO375C_EN	
MODEL LIFT:				CLIENT:	<p><b>MP LIFTS</b></p>
<b>MP GO! FLEX XL</b>				WORK SITUATION:	
CAPACITY: [N° PERSONS]			5		
NOMINAL LOAD: [kg]			375		
SPEED: [m/s]			1		
FREQUENCY: [Hz]			50		
TENSION: [V]		380V [Three-phase]			

# 04B-MACHINE ROOM



SCALE[\*]: 1:20

Minimum machine room height: 2100 mm.  
 [EN 81-20:2014 5.2.6.3.2.1]  
 Minimum clearance door: 600x2000 mm.  
 [EN 81-20:2014 5.2.3.2 a]

DRAWING	DATE	REV.	SHEET	[*] Unbounded dimensions in drawings are indicative and not binding.	
MP	2017	00	4/7	REFERENCE: MPGO!FLEXXLFONDO375C_EN	
MODEL LIFT:				CLIENT:	
<b>MP GO! FLEX XL</b>				WORK SITUATION:	
CAPACITY: [N° PERSONS]			5		
NOMINAL LOAD: [kg]			375		
SPEED: [m/s]			1		
FREQUENCY: [Hz]			50		
TENSION: [V]			380V [Three-phase]		
				<b>MP LIFTS</b>	

# 05-PIT LAYOUT

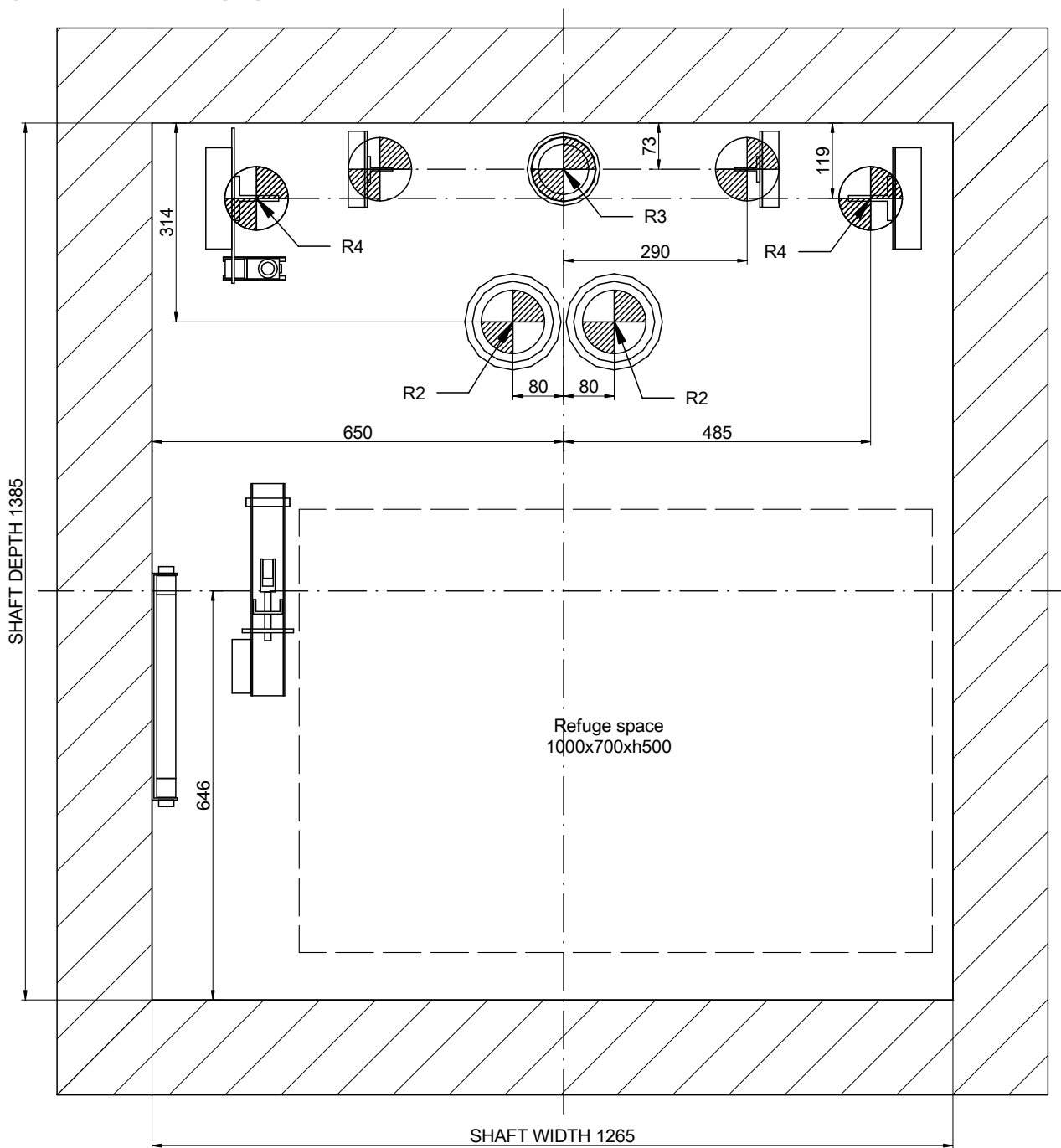



SCALE[\*]: 1:10

REACTIONS [N] [max.]			
R2	22800		
R3	36700	R4 13400	
Sx	2300	Sy 720	

DRAWING	DATE	REV.	SHEET	[*] Unbounded dimensions in drawings are indicative and not binding.	
MP	2017	00	5/7	REFERENCE: MPGO!FLEXXLFONDO375C_EN	
MODEL LIFT:				CLIENT:	MP LIFTS
MP GO! FLEX XL					
CAPACITY: [N° PERSONS]			5	WORK SITUATION:	
NOMINAL LOAD: [kg]			375		
SPEED: [m/s]			1		
FREQUENCY: [Hz]			50		
TENSION: [V]			380V [Three-phase]		

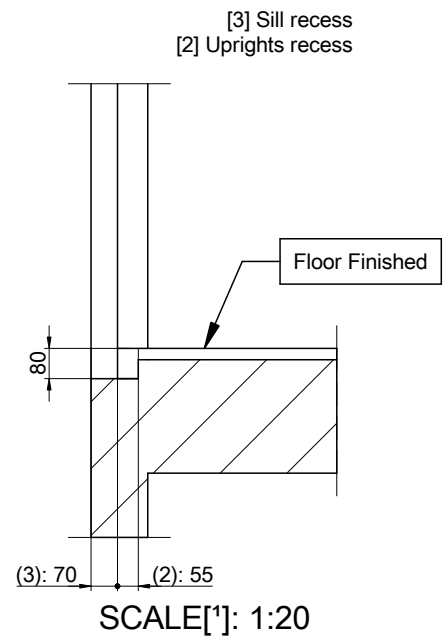
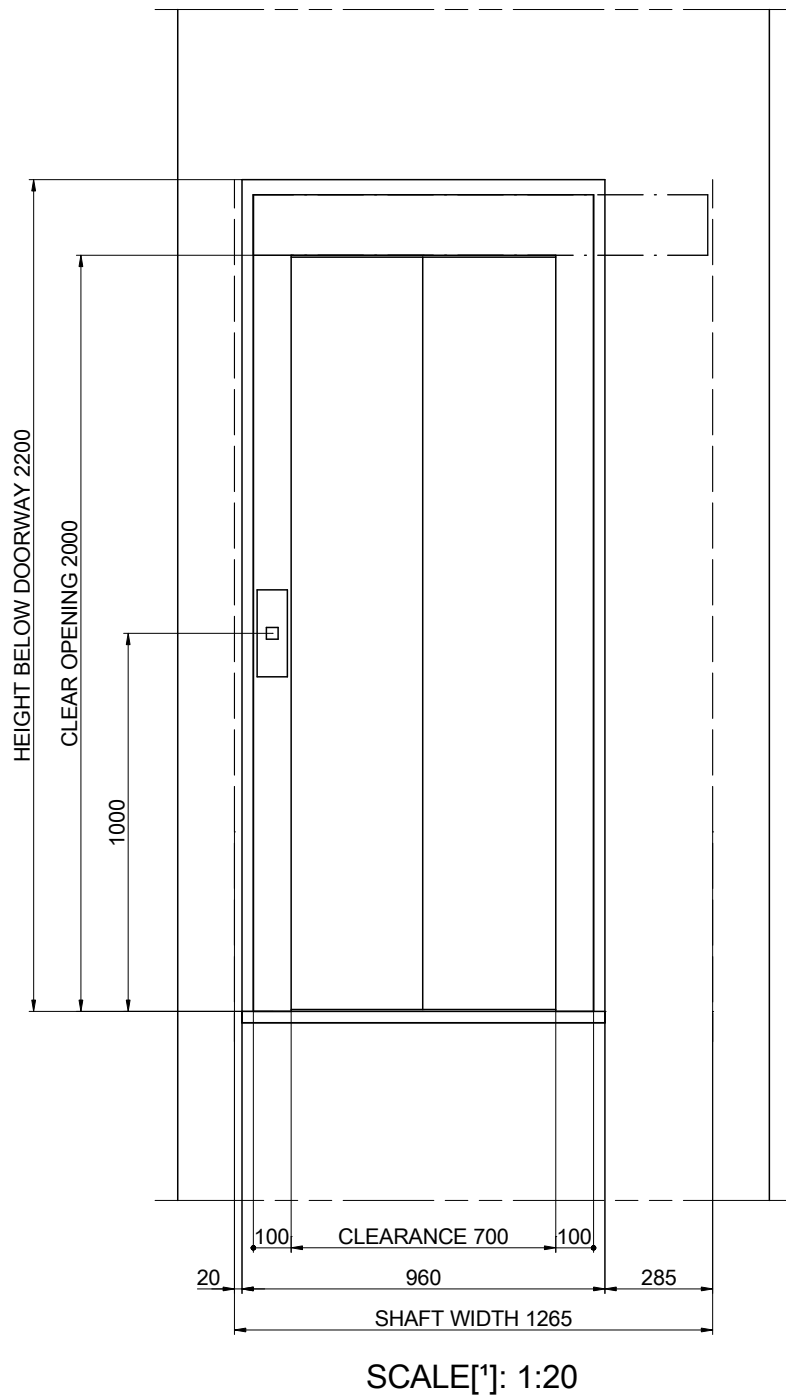
# 06-DOOR HOLE DETAIL



DRAWING	DATE	REV.	SHEET	[*] Unbounded dimensions in drawings are indicative and not binding.	
MP	2017	00	6/7	REFERENCE: MPGO!FLEXXLFONDO375C_EN	
MODEL LIFT:				CLIENT:	WORK SITUATION:
MP GO! FLEX XL					
CAPACITY: [N° PERSONS]			5	<p style="text-align: center; font-size: 2em; font-weight: bold;">MP LIFTS</p>	
NOMINAL LOAD: [kg]			375		
SPEED: [m/s]			1		
FREQUENCY: [Hz]			50		
TENSION: [V]			380V [Three-phase]		

# 07-HEADROOM

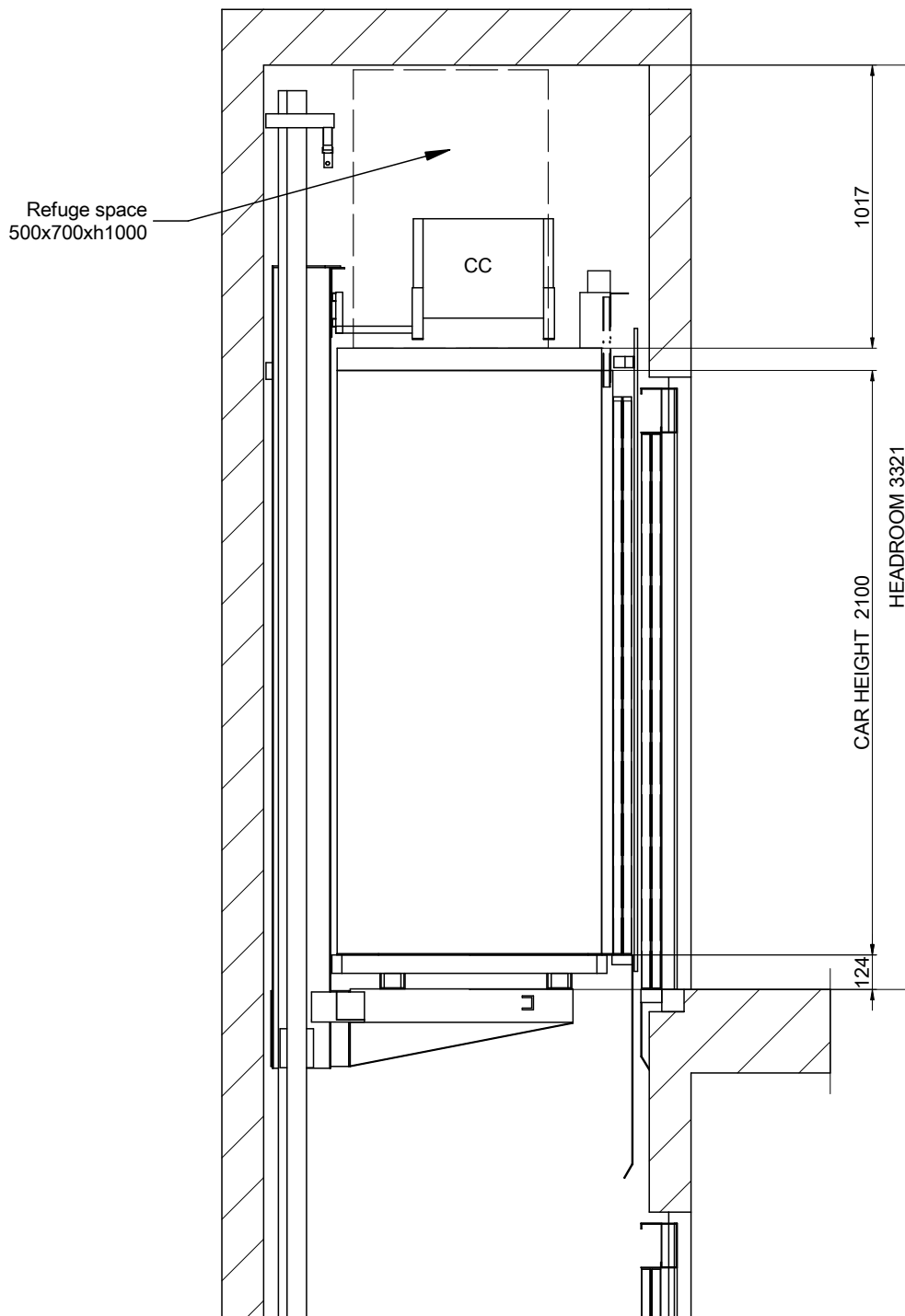

SCALE[\*]: 1:25

DRAWING	DATE	REV.	SHEET	[*] Unbounded dimensions in drawings are indicative and not binding.	
MP	2017	00	7/7	REFERENCE: MPGO!FLEXXLFONDO375C_EN	
MODEL LIFT:				CLIENT:	WORK SITUATION:
MP GO! FLEX XL					
CAPACITY: [N° PERSONS]			5	<h2>MP LIFTS</h2>	
NOMINAL LOAD: [kg]			375		
SPEED: [m/s]			1		
FREQUENCY: [Hz]			50		
TENSION: [V]			380V [Three-phase]		