

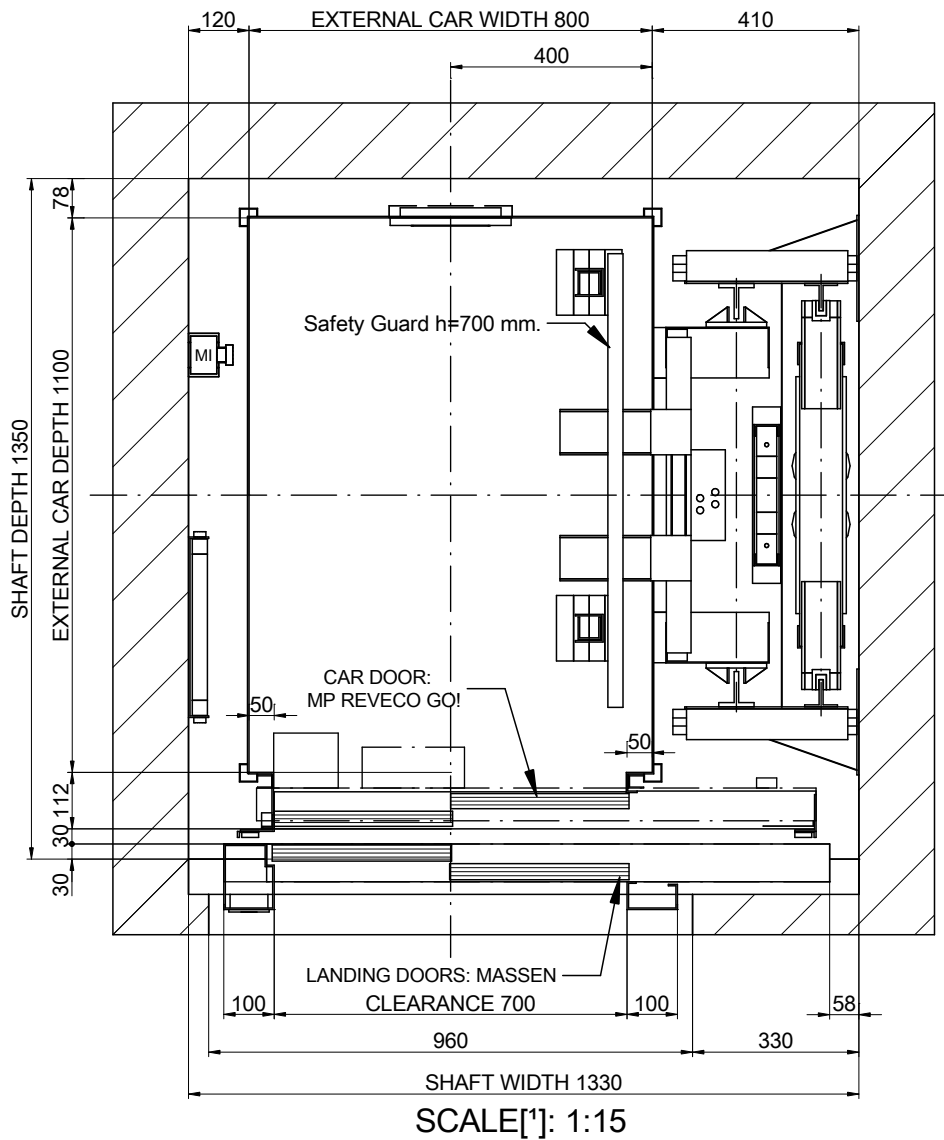

01-PLAN VIEW



NOMENCLATURE

CC: Car ceiling connection box
MI: Inspection control station

DRAWING	DATE	REV.	SHEET	[*] Unbounded dimensions in drawings are indicative and not binding.	
MP	2017	00	1/7	REFERENCE: MPGO!FLEXLATERAL320C_EN	
MODEL LIFT:				CLIENT: WORK SITUATION:	<p style="text-align: center; font-size: 24px; font-weight: bold;">MP LIFTS</p>
MP GO! FLEX					
CAPACITY: [N° PERSONS]			4		
NOMINAL LOAD: [kg]			320		
SPEED: [m/s]			1		
FREQUENCY: [Hz]			50		
TENSION: [V]		380V [Three-phase]			

02-SIDE VERTICAL SECTION

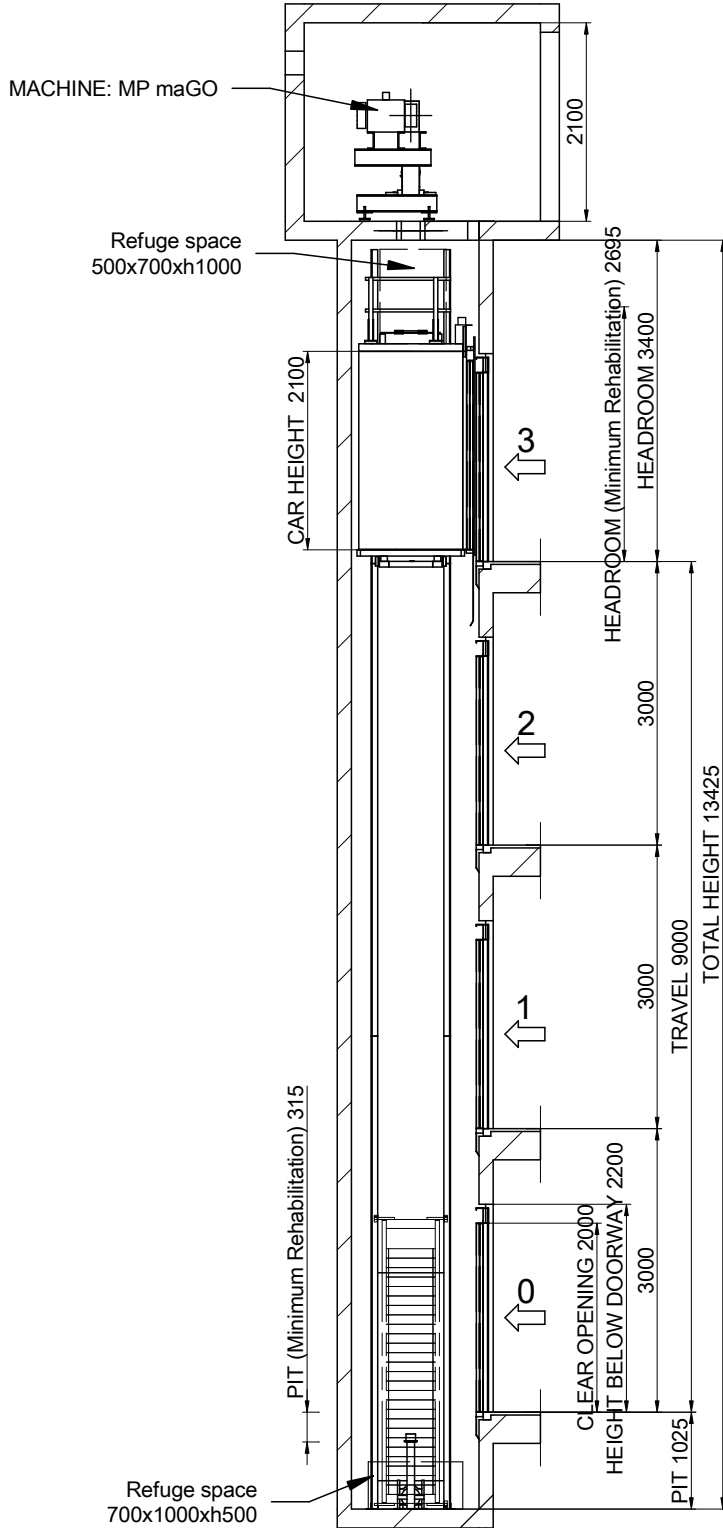

SCALE[*]: 1:80

		[*] Unbounded dimensions in drawings are indicative and not binding.	
		REFERENCE: MPGOIFLEXLATERAL320C_EN	
DRAWING	DATE	REV.	SHEET
MP	2017	00	2/7
MODEL LIFT:			
MP GO! FLEX			
CAPACITY: [N° PERSONS]		4	
NOMINAL LOAD: [kg]		320	
SPEED: [m/s]		1	
FREQUENCY: [Hz]		50	
TENSION: [V]		380V [Three-phase]	
CLIENT: WORK SITUATION:			MP LIFTS

Flat and levelled floor, protected against water leaking.
 [EN81-20:2014 5.2.1.9]
 Foresee pit access device
 [EN81-20:2014 5.2.2.4]
 Stop device
 [EN81-20:2014 5.2.1.5.1. a)
 Inspection control station.
 [EN81-20:2014 5.2.1.5.1. b)
 Power supply
 [EN81-20:2014 5.2.1.5.1. c)
 Light switch
 commuted with the cabinet.
 [EN81-20:2014 5.2.1.5.1. d)

04B-MACHINE ROOM

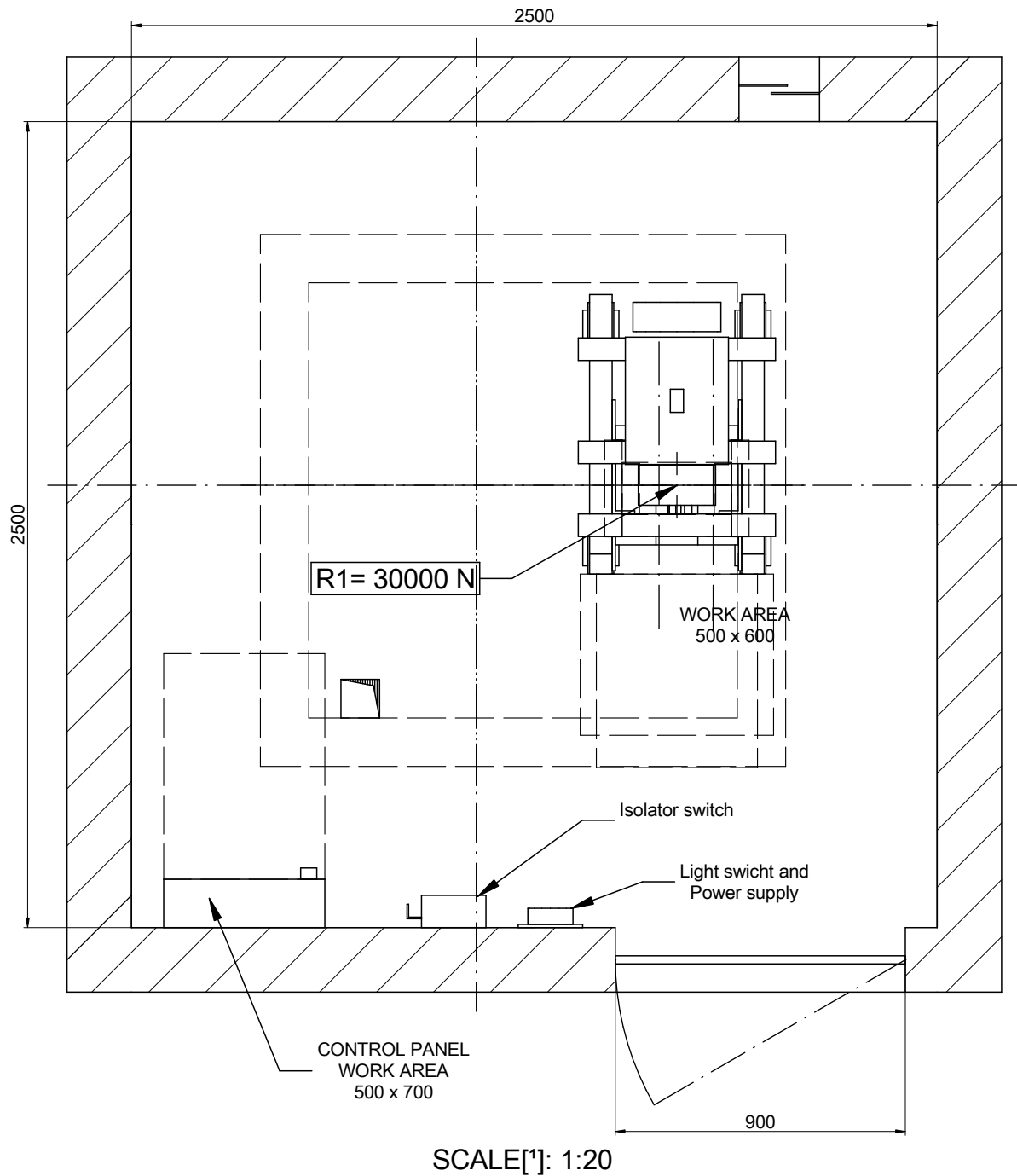

Minimum machine room height: 2100 mm.
[EN 81-20:2014 5.2.6.3.2.1]
Minimum clearance door: 600x2000 mm.
[EN 81-20:2014 5.2.3.2 a]

DRAWING	DATE	REV.	SHEET	[*] Unbounded dimensions in drawings are indicative and not binding.	
MP	2017	00	4/7	REFERENCE: MPGO!FLEXLATERAL320C_EN	
MODEL LIFT:				CLIENT: WORK SITUATION:	MP LIFTS
MP GO! FLEX					
CAPACITY: [N° PERSONS]			4		
NOMINAL LOAD: [kg]			320		
SPEED: [m/s]			1		
FREQUENCY: [Hz]			50		
TENSION: [V]		380V [Three-phase]			

05-PIT LAYOUT

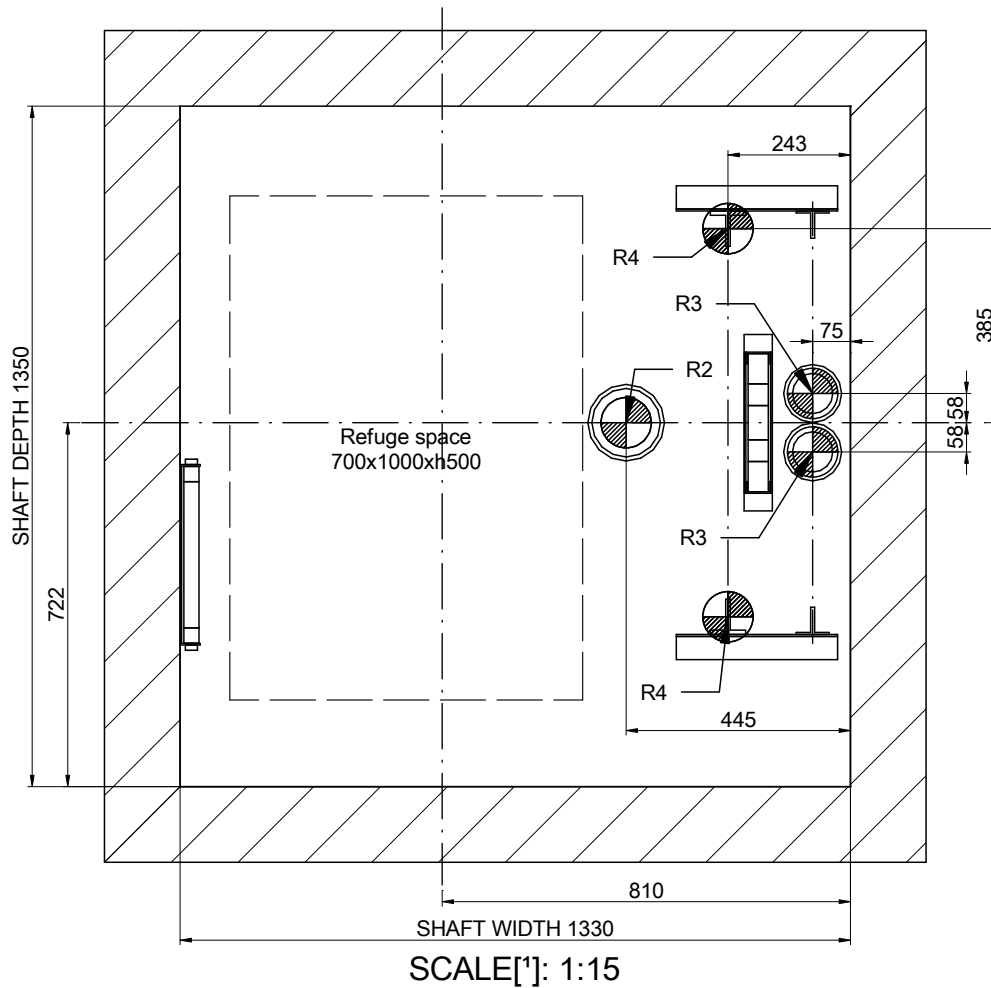

REACTIONS [N] [max.]			
R2	39600		
R3	16100	R4 12600	
Sx	2100	Sy 385	

DRAWING	DATE	REV.	SHEET	[*] Unbounded dimensions in drawings are indicative and not binding.	
MP	2017	00	5/7	REFERENCE: MPGO!FLEXLATERAL320C_EN	
MODEL LIFT:				CLIENT: WORK SITUATION:	<p>MP LIFTS</p>
MP GO! FLEX					
CAPACITY: [N° PERSONS]			4		
NOMINAL LOAD: [kg]			320		
SPEED: [m/s]			1		
FREQUENCY: [Hz]			50		
TENSION: [V]		380V [Three-phase]			

06-DOOR HOLE DETAIL

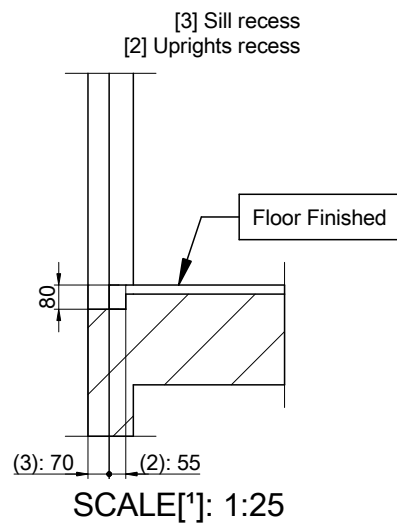
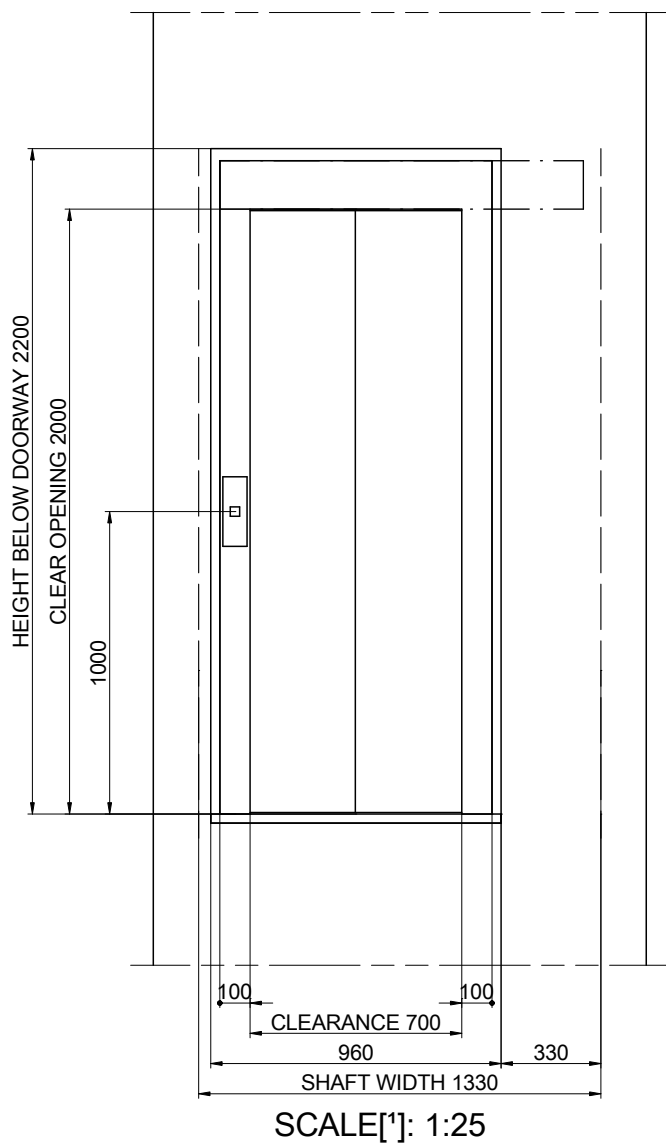

DRAWING	DATE	REV.	SHEET	[*] Unbounded dimensions in drawings are indicative and not binding.	
MP	2017	00	6/7	REFERENCE: MPGO!FLEXLATERAL320C_EN	
MODEL LIFT:				CLIENT: WORK SITUATION:	
MP GO! FLEX					
CAPACITY: [N° PERSONS]		4			
NOMINAL LOAD: [kg]		320			
SPEED: [m/s]		1			
FREQUENCY: [Hz]		50			
TENSION: [V]		380V [Three-phase]		MP LIFTS	

07-HEADROOM

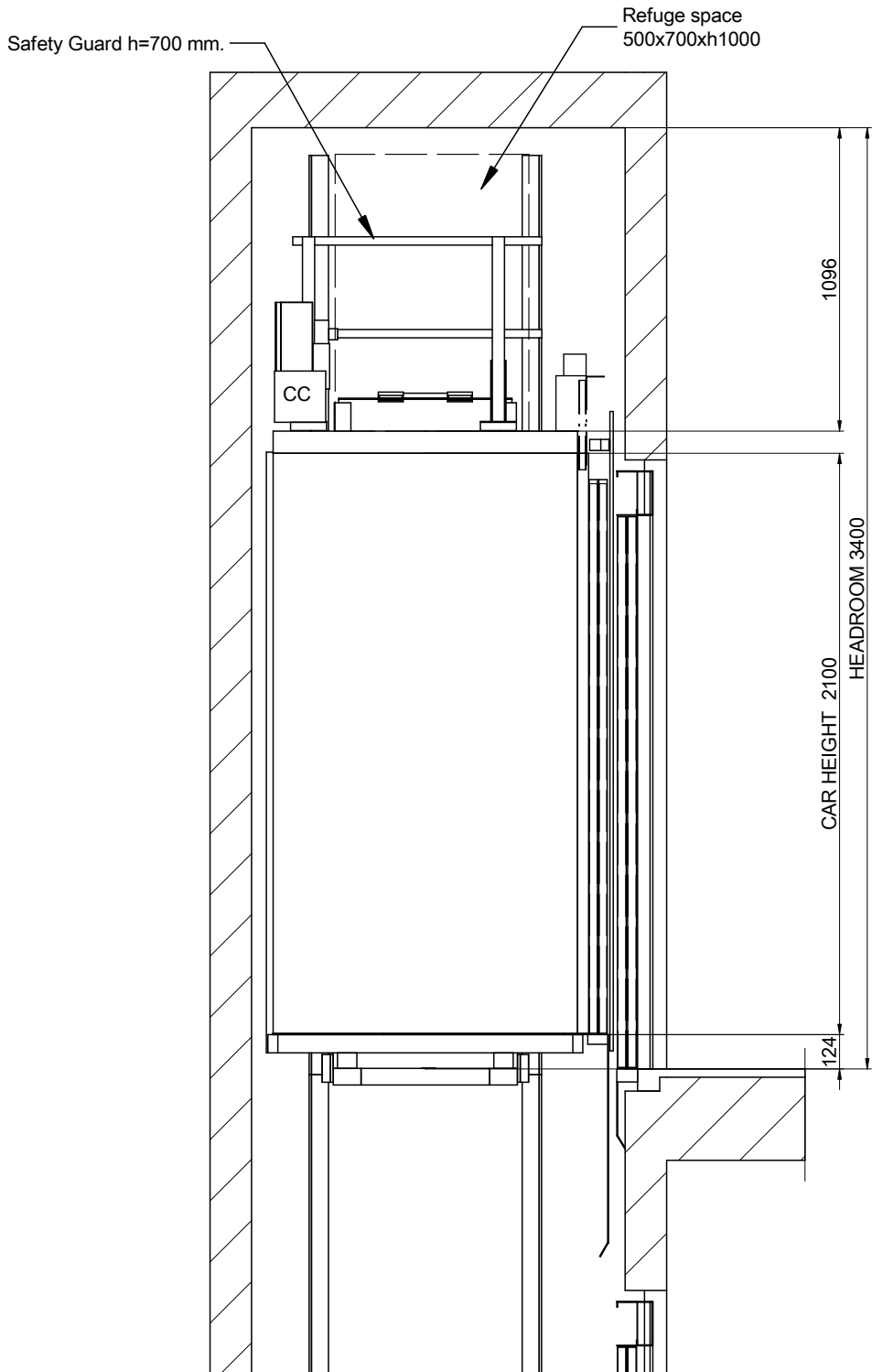

SCALE[*]: 1:25

DRAWING	DATE	REV.	SHEET	[*] Unbounded dimensions in drawings are indicative and not binding. REFERENCE: MPGO!FLEXLATERAL320C_EN	
MP	2017	00	7/7		
MODEL LIFT:				CLIENT:	WORK SITUATION:
MP GO! FLEX					
CAPACITY: [N° PERSONS]			4	<h2>MP LIFTS</h2>	
NOMINAL LOAD: [kg]			320		
SPEED: [m/s]			1		
FREQUENCY: [Hz]			50		
TENSION: [V]			380V [Three-phase]		