

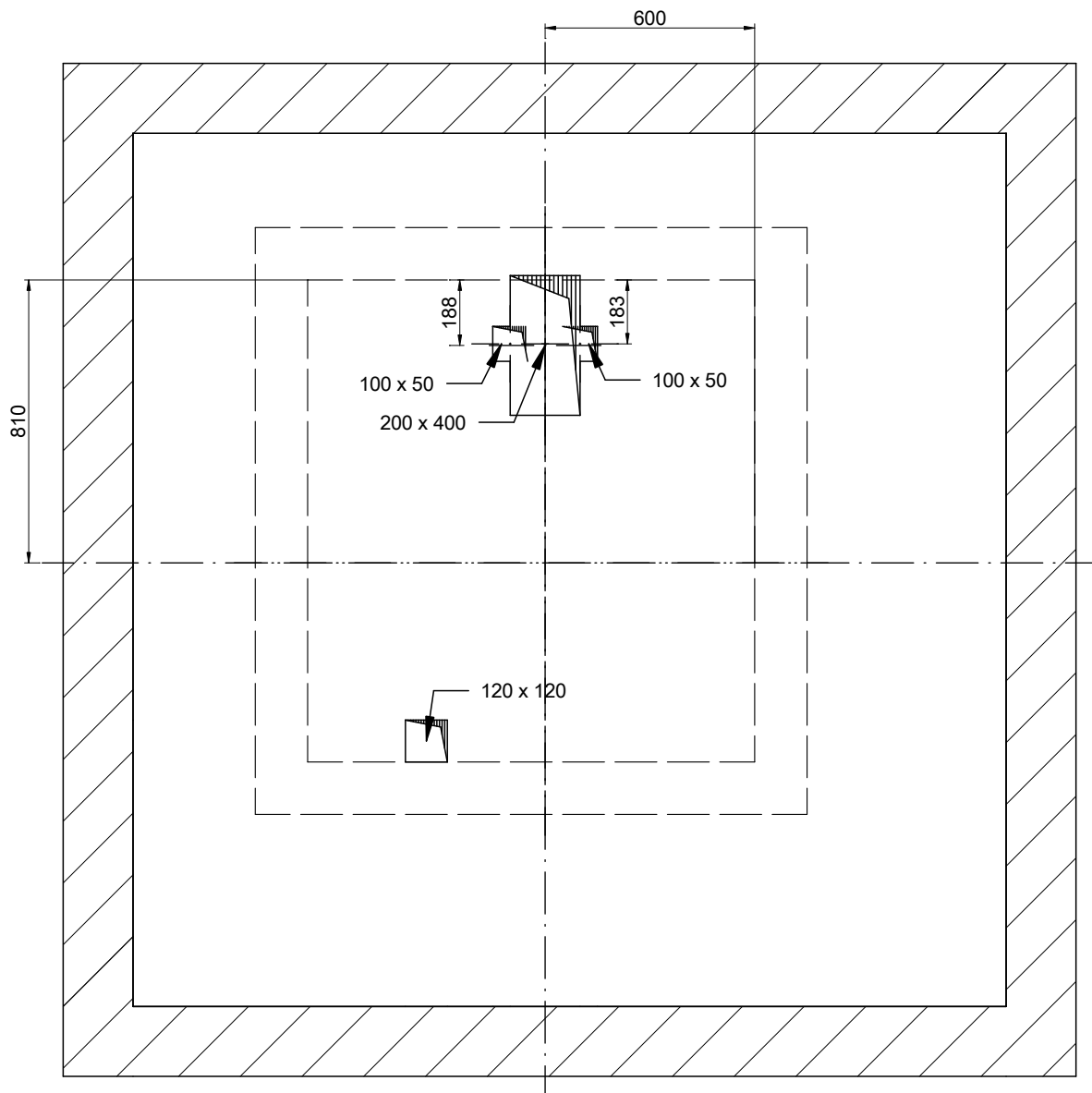

04-DETAIL DE LA DALLE



ECHELLE[*]: 1:20

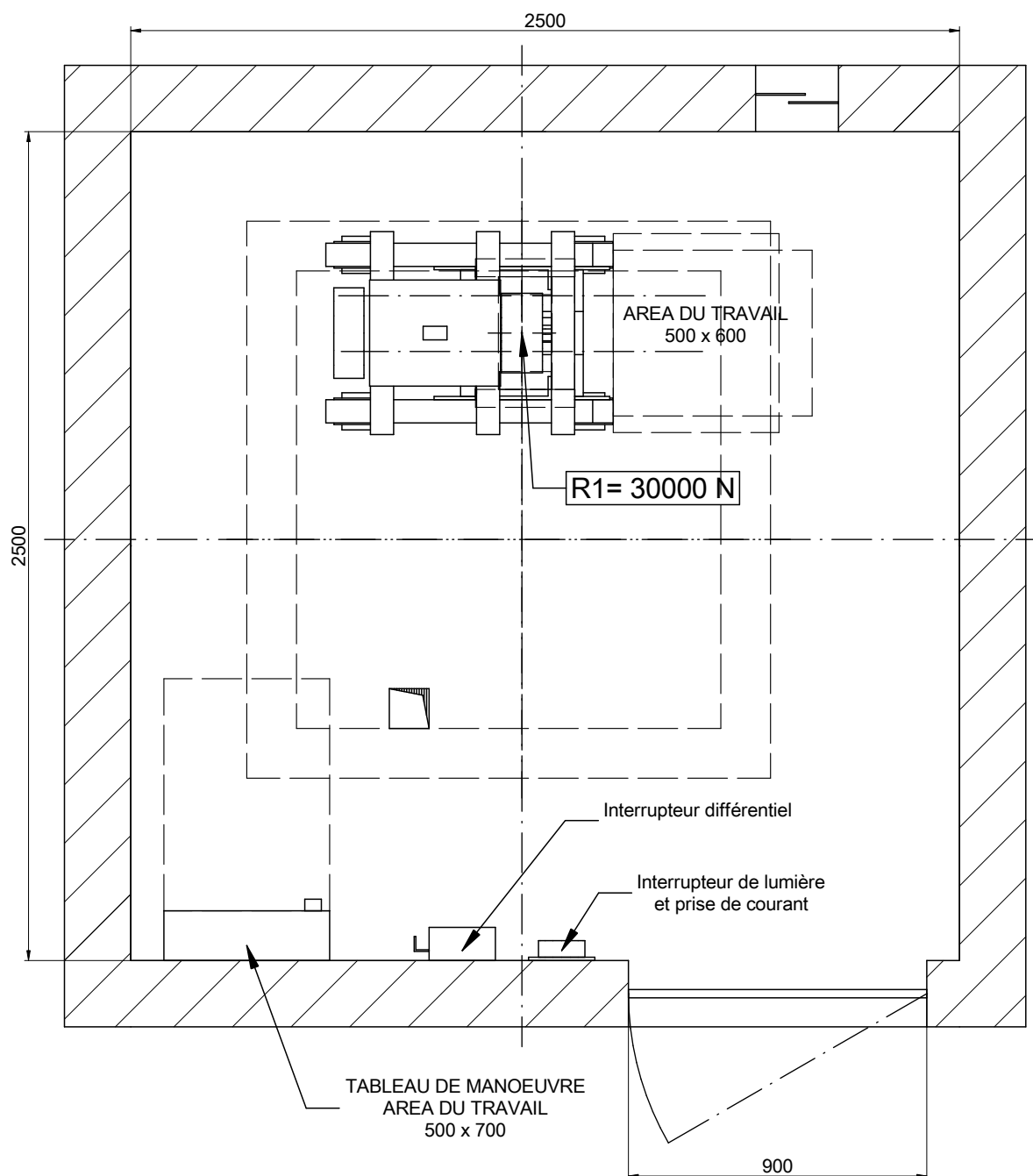

DESSINÉ	DATE	REV.	FEUILLE	[*] Les traits non cotés ne doivent pas servir pour des mesures.	
MP	2017	00	3/7		
MODELE ASCENSEUR:				CLIENT:	
MP GO! FLEX					
CAPACITE: [Nbre DE PERS.]		4		ADRESSE CHANTIER:	
CHARGE NOMINALE: [kg]		320			
VITESSE: [m/s]		1		<p style="text-align: center;">MP ASCENSEURS</p>	
FREQUÉENCE: [Hz]		50			
TENSION RESEAU: [V]		380V [Triphasée]			

04B-LOCAL DES MACHINES



Hauteur mini de la machinerie: 2100 mm.
 [EN 81-20:2014 5.2.6.3.2.1]
 PL mini de la porte: 600x2000 mm.
 [EN 81-20:2014 5.2.3.2 a]

ECHELLE[*]: 1:20

DESSINÉ	DATE	REV.	FEUILLE	[*] Les traits non cotés ne doivent pas servir pour des mesures.	
MP	2017	00	4/7	REFERENCE:	
MODELE ASCENSEUR:				CLIENT:	
MP GO! FLEX					
CAPACITE: [Nbre DE PERS.]		4		ADRESSE CHANTIER:	<h2>MP ASCENSEURS</h2>
CHARGE NOMINALE: [kg]		320			
VITESSE: [m/s]		1			
FREQUÉNCÉ: [Hz]		50			
TENSION RESEAU: [V]		380V [Triphasée]			

05-PLAN DE LA CUVETTE

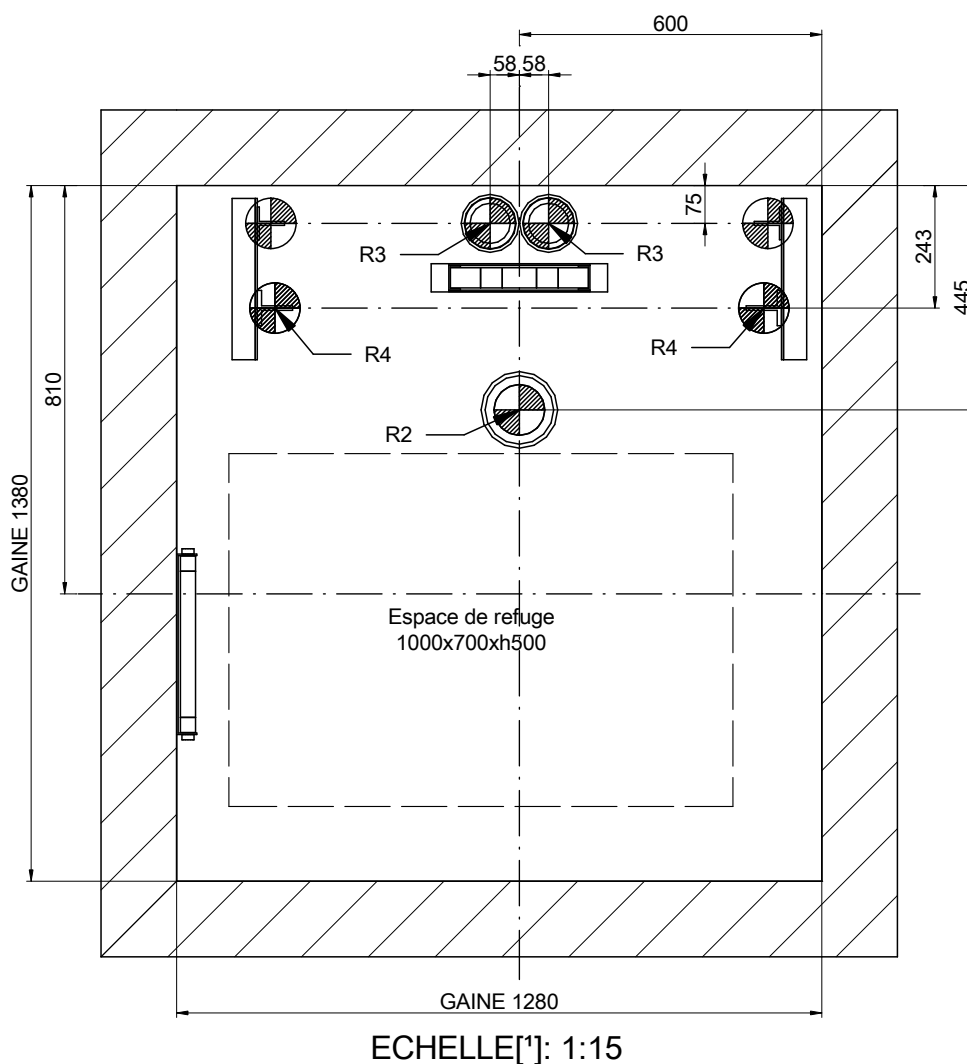

REACTIONS [N] [max.]			
R2	39600		
R3	16100	R4 12600	
Sx	2100	Sy 385	

DESSINÉ	DATE	REV.	FEUILLE	[*] Les traits non cotés ne doivent pas servir pour des mesures.	
MP	2017	00	5/7	REFERENCE:	
MODELE ASCENSEUR:				CLIENT:	ADRESSE CHANTIER:
MP GO! FLEX					
CAPACITE: [Nbre DE PERS.]	4			<h2>MP ASCENSEURS</h2>	
CHARGE NOMINALE: [kg]	320				
VITESSE: [m/s]	1				
FREQUENCE: [Hz]	50				
TENSION RESEAU: [V]	380V [Triphasée]				

06-DETAIL PORTE PALIERE

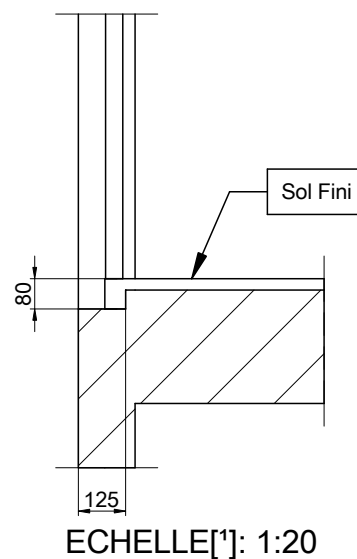
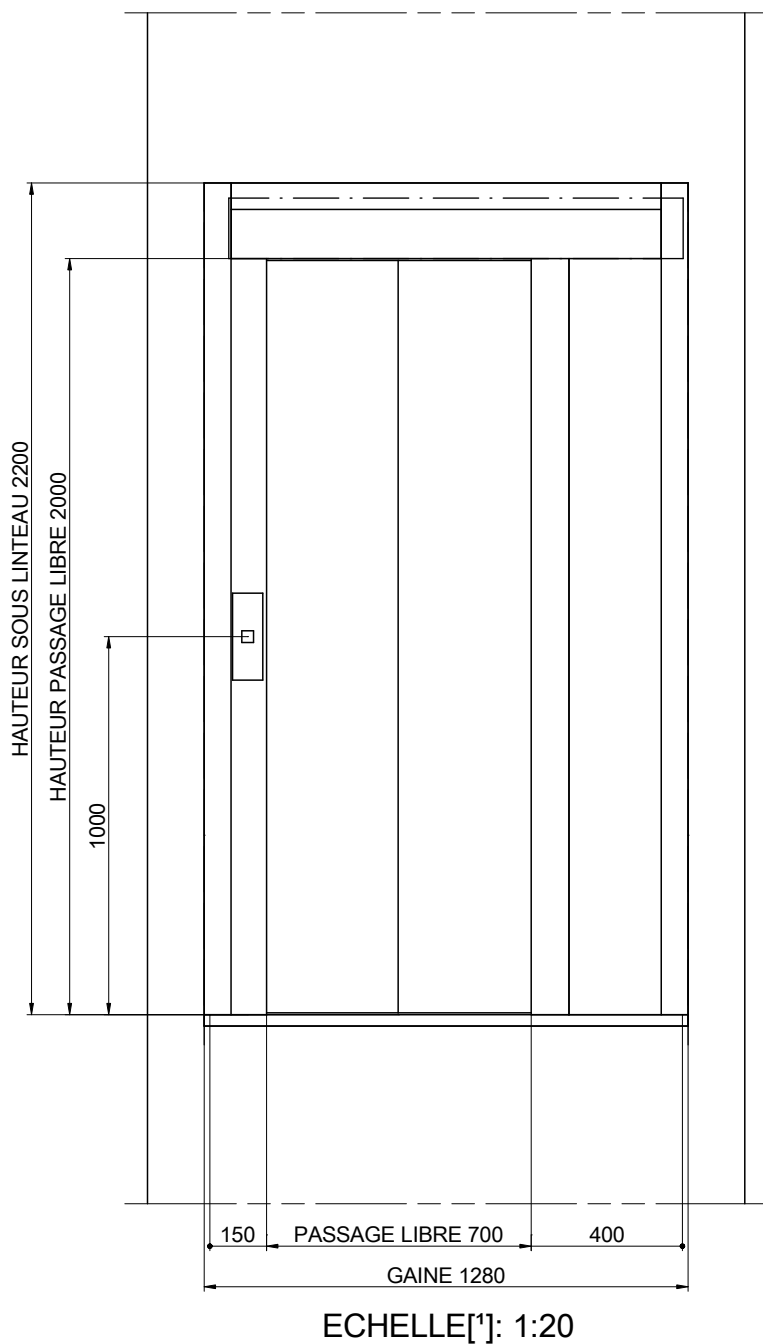

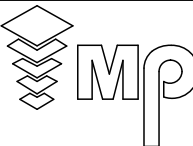
DESSINÉ	DATE	REV.	FEUILLE	[*] Les traits non cotés ne doivent pas servir pour des mesures.	
MP	2017	00	6/7		
MODELE ASCENSEUR:				CLIENT: ADRESSE CHANTIER:	
MP GO! FLEX					
CAPACITE: [Nbre DE PERS.]		4			
CHARGE NOMINALE: [kg]		320			
VITESSE: [m/s]		1			
FREQUÉENCE: [Hz]		50			
TENSION RESEAU: [V]		380V [Triphasée]		MP ASCENSEURS	

07-HAUTEUR D ARRIVEE

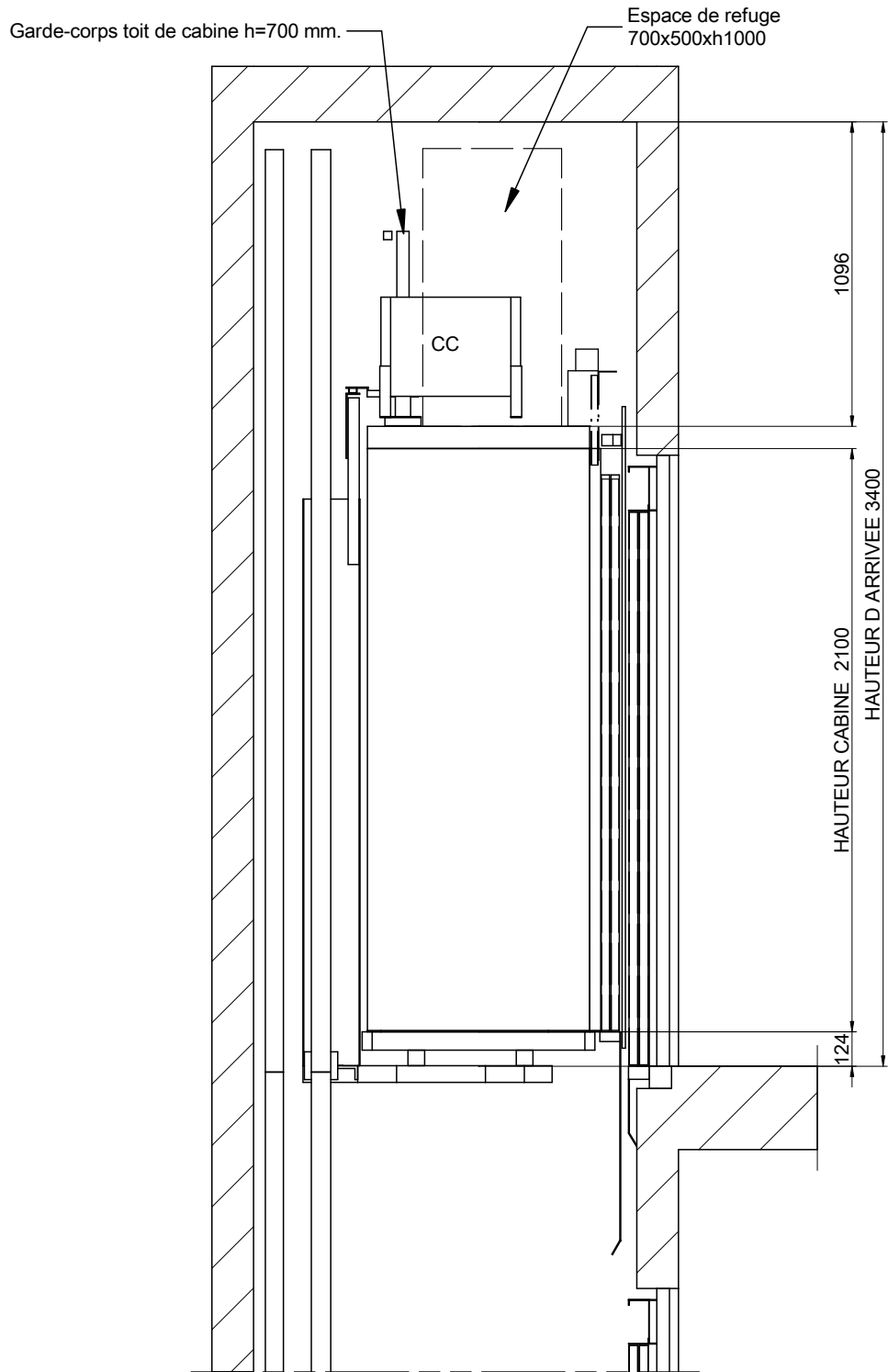

ECHELLE[*]: 1:25

DESSINÉ	DATE	REV.	FEUILLE	[*] Les traits non cotés ne doivent pas servir pour des mesures.	
MP	2017	00	7/7		
MODELE ASCENSEUR:				CLIENT:	ADRESSE CHANTIER:
MP GO! FLEX					
CAPACITE: [Nbre DE PERS.]	4			<p style="text-align: center;">MP ASCENSEURS</p>	
CHARGE NOMINALE: [kg]	320				
VITESSE: [m/s]	1				
FREQUENCE: [Hz]	50				
TENSION RESEAU: [V]	380V [Triphasée]				